

# ASSEMBLY INSTRUCTIONS

FOR

## SUPERLITE 6 BIG BRAKE FRONT HUB KIT

WITH 14.00" DIAMETER VENTED ROTOR

1974 - 1980 PINTO • 1974 - 1978 MUSTANG II

(FIVE LUG DISC BRAKE SPINDLE CONFIGURATION ONLY)\*

PART NUMBER GROUP

**140-9802**

**DISC BRAKES SHOULD ONLY BE INSTALLED BY SOMEONE  
EXPERIENCED AND COMPETENT IN THE INSTALLATION AND  
MAINTENANCE OF DISC BRAKES**

**READ ALL WARNINGS**



## Photographic Tip

**Important** and highly recommended: Take photos of brake system before disassembly and during the disassembly process. In the event, trouble-shooting photos can be life savers. Many vehicles have undocumented variations, photos will make it much simpler for Wilwood to assist you if you have a problem.

## Exploded Assembly Diagram

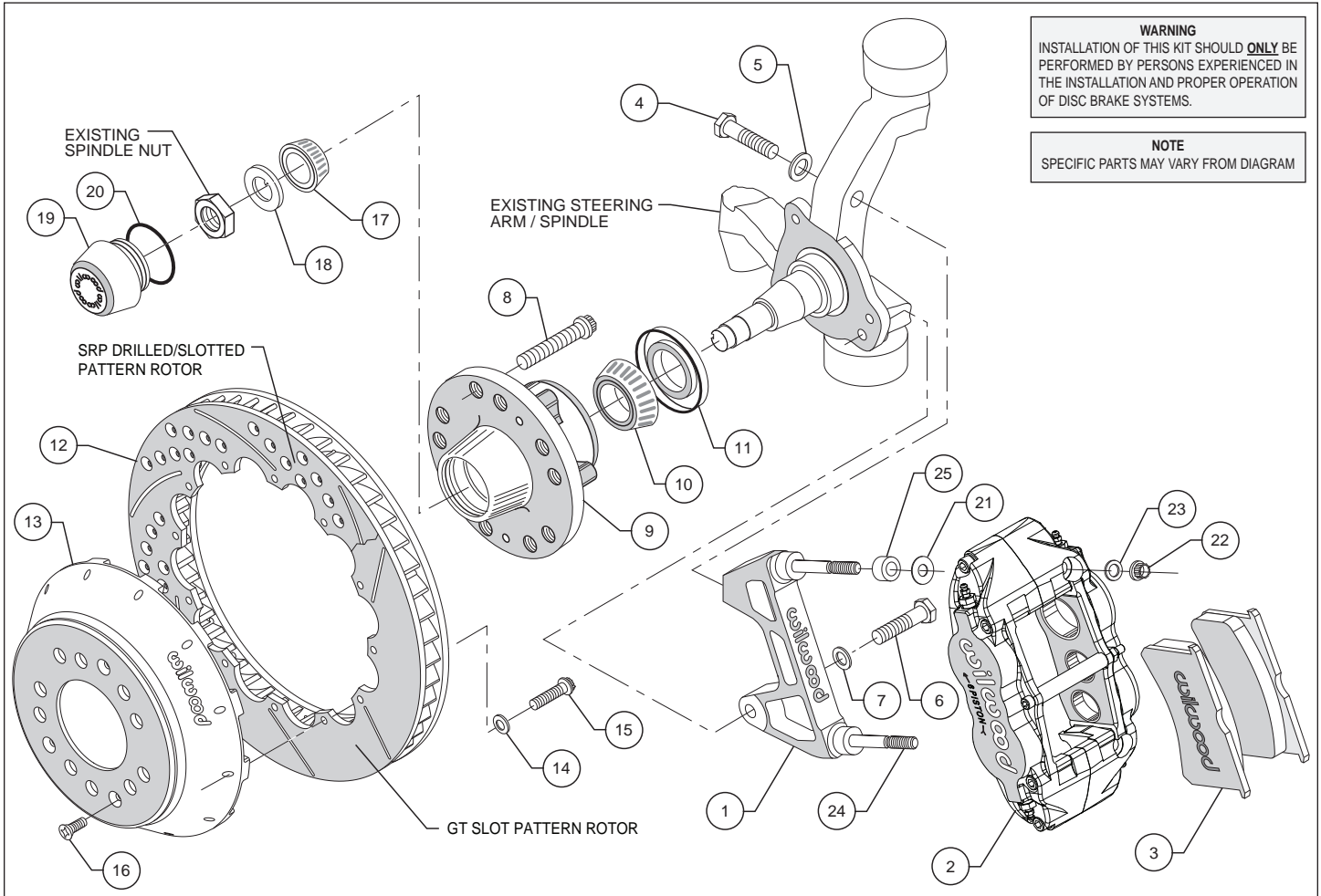

Figure 1. Typical Installation Configuration

## Parts List

<u>ITEM NO.</u>	<u>PART NO.</u>	<u>DESCRIPTION</u>	<u>QTY</u>
1	250-9854/55	Bracket, Caliper Mounting (pair, one each, left and right)	1
2	120-11780/81-BK	Caliper, Superlite 6R, (one each, left and right)	2
2A	120-8079/80-RSP	Caliper, Polished Superlite 6R	2
2B	120-11780/81-RD	Caliper, Red Superlite 6R	2
3	150-8855K	Pad, BP-10 Compound, Axle Set	2
4	230-9531	Bolt, 1/2-13 x 2.00 Long, Hex Head	2
5	240-11102	Washer, .515 I.D. x .875 O.D. x .063 Thick	2
6	230-9818	Bolt, 7/16-14 x 1.75 Long, Hex Head	2
7	240-11101	Washer, .453 I.D. x .750 O.D. x .063 Thick	2
8	230-6959	Stud, 1/2-20 x 2.00 Long, 12 Point	10
9	270-6989	Hub Assembly	2
10	370-0884	Cone, Inner Bearing	2
11	380-0885	Seal, Grease	2
12	160-8402/03	Rotor, 1.10" Thick x 14.00" Dia, 12 x 8.75" Bolt Circle (L/H & R/H)	2
12A	160-8400/01	Rotor, Drilled and Slotted	2
13	170-6994	Hat, 5 x 4.50/4.75, 1.88 Offset, 12 x 8.75 Bolt Circle	2
14	240-11240	Washer, .265 I.D. x .500 O.D. x .063 Thick	24
15	230-6737	Bolt, 1/4-20 x 1.00 Long, 12 Point	24
16	230-10419	Bolt, 1/4-20 x 0.50 Long, Flat Head	6
17	370-0882	Cone, Outer Bearing	2
18	240-2444	Washer, 7/8 Spindle	2
19	270-2158	Cap, Dust	2
20	211-1674	O-ring	2
21	240-1159	Shim, .035 Thick	24
22	230-9183	Nut, 3/8-24, Self-Locking, 12 PT	4
23	240-10190	Washer, .391 I.D. x .625 O.D. x .063 Thick	4
24	230-9079	Stud, 3/8-16 x 3/8-24 x 3.15 Long (pre-installed in bracket)	4
25	300-2089	Spacer, .500 Long	4

### NOTES:

Part Number 230-4572 Bolt Kit, rotor to hat, includes P/N's 230-6737 and 240-11240

Part Number 230-9883 Bolt Kit, bracket to spindle, includes P/N's 230-9531, 230-9818, 240-11101, and 240-11102

Part Number 249-9867/68 Bracket Kit, caliper mounting, includes P/N's 230-9079, 230-9183, 240-1159, 240-10190, 250-9854, 250-9855 and 300-2089

Part Number 230-7032 Bolt Kit, hub to hat, includes P/N 230-10419

Item 12A is an optional item and is included in the "-D" Kits, add "-D" to end of part number when ordering

Item 2A is an optional item and is included in the "-P" kits, add "-P" to end of part number when ordering

Item 2B is an optional item and is included in the "-R" kits, add "-R" to end of part number when ordering

## General Information

*Installation of this kit should **ONLY** be performed by persons experienced in the installation and proper operation of disc brake systems. Before installation begins, please read the complete procedure thoroughly to familiarize yourself with the process, and double check the following items to ensure a trouble-free installation.*

- Inspect the package contents against the parts list to ensure that all components and hardware are included
- Make sure this is the correct kit to match the exact make and model year of the vehicles spindle (i.e., hubs for a 1975 Mustang spindle may not fit a 1982 Mustang spindle).
- Verify your wheel clearance using Figure 2.
- Verify the hub stud pattern in this kit (5 x 4.50 or 5 x 4.75) matches the stud pattern of the vehicles wheels.

## Disassembly and Assembly Instructions

### Disassembly Instructions:

- Disassemble the original equipment front brakes:
  - Raise the front wheels off the ground and support the front suspension according to the vehicle manufacturer's instructions.
  - Disconnect the brake hoses from the original equipment caliper. Unbolt and remove the original caliper from the original caliper bracket.
  - Remove the center cap, cotter pin, nut lock wheel bearing nut and wheel bearing washer. Save the wheel bearing nut and nut locking device.
  - Remove the brake drum or rotor and hub assembly, including the wheel bearings.
  - Remove the original caliper bracket bolts and caliper bracket. Remove the dust shield retaining bolts and the dust shield.
- Thoroughly clean the spindles.

### Assembly Instructions (numbers in parenthesis refer to the part list/diagram on the preceding pages):

- The caliper mount bracket assembly (1) should be installed first with clean, dry threads on the mounting bolts. Install the bracket from the rear side of the spindle by sliding the upper mounting bolt (4) through flat washer (5) and the upright into the upper bolt hole on the bracket. Attach the lower portion of the bracket by sliding bolt (6) through flat washer (7) and into the lower hole on the backside of the spindle. The bracket must tighten squarely against the inboard side of the spindle face plate/upright. Inspect for interference from casting irregularities, machining ridges, burrs, etc. If everything fits correctly, then remove the mounting bolts (4 and 6), coat threads with red *Loctite*® 271 and reinstall. Torque bolt (4) to 65 ft-lbs., and bolt (6) to 42 ft-lbs.
- Install wheel studs (8) into the hub (9). Torque to 77 ft-lb. **NOTE:** There are two lug patterns of five holes each in the hub (5 x 4.50 and 5 x 4.75). Make sure of the correct hole pattern for the wheel application before installing the studs into the hub.
- Pack the large inner bearing cone (10) with high temperature disc brake bearing grease (available from your local auto parts store) and install into the backside of the hub (9).
- Install the grease seal (11) into the backside of the hub (9).
- Pack the small outer bearing cone (17) with high temperature disc brake bearing grease and install into front side of the hub (9). Slide the hub assembly (9, 10, 11 and 17) onto the spindle. Secure using spindle washer (18), stock adjusting nut, and nut locking device. Adjust wheel bearing pre-load per Original Equipment Manufacturer (OEM) specifications.
- Install the O-ring (20) and the dust cap (19) into the hub (5). **NOTE:** O-ring (20) friction will not allow cap (19) to unscrew on its own.
- With the larger I.D. side of the rotor (12) facing away from the hat (13), bolt rotor (12) to hat (13) through the backside of the rotor using washers (14) and bolts (15). Using an alternating sequence, apply red *Loctite*® 271 to the threads and torque bolts to 155 in-lb. For an added measure of security, the bolts may be safety wired using standard 0.032 inch diameter stainless steel safety wire as shown in Figure 3. Please refer to Wilwood's data sheet DS-386

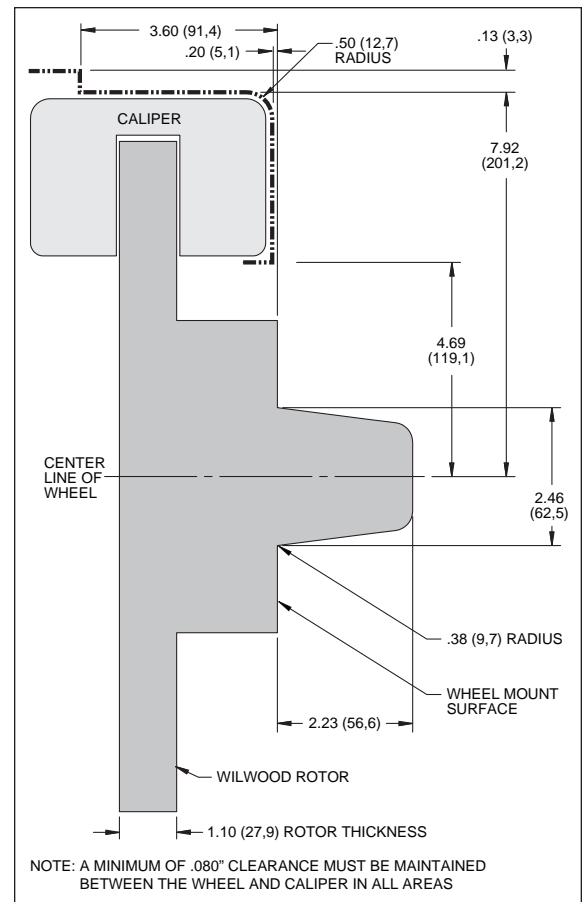

Figure 2. Wheel Clearance Diagram

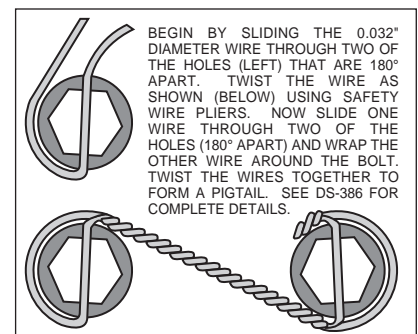

Figure 3. Safety Wire Diagram

## Assembly Instructions (Continued)

- Slide the rotor/hat assembly over the studs (8) in the hub (9) taking care to align the small countersunk holes in the hat (13) with the small threaded holes in the hub (9). Install three flat head socket head screws (16) through the small holes in the hat (13) and torque to 85 **in-lb**. Check to be sure the hat seats squarely against the spindle.
- NOTE:** *This kit contains distinct right and left hand calipers that must be mounted in a specific direction, as described below.* Lubricate the caliper mounting studs (24) with lightweight oil. Initially place one .035" thick shim (21) and spacer (25) on each stud as shown in Figure 1. Mount the caliper (2) onto the bracket (1) using lock nuts (22) and washers (23), Figure 1. Ensure that the caliper is mounted so that the largest pistons are at the rotor exit end of the caliper, in relation to the direction of rotor rotation.
- Remove the caliper center bridge pad retainer bolt, nut, and tube from the caliper. Slide the brake pads (3) into place. They should install easily without interference. Check that the outside radius of the brake pad is aligned with the outside diameter radius of the rotor face. Add or subtract shims (21) between the caliper and mount bracket to gain the proper alignment. Lubricate caliper mounting studs and nuts with lightweight oil, reinstall the caliper and torque the caliper nuts (22) to 28 ft-lb. Reinstall the center bridge pad retainer tube, bolt, and locknut. The locknut should be snug without play in the bolt or tube. Be cautious not to over tighten.
- NOTE:** *OEM rubber brake hoses generally cannot be adapted to Wilwood calipers. The caliper inlet fitting is a 1/8-27 NPT.* The preferred method is to use steel adapter fittings at the caliper, either straight, 45 or 90 degree and enough steel braided line to allow for full suspension travel and turning radius, lock to lock. **Carefully route lines to prevent contact with moving suspension, brake or wheel components.** Wilwood hose kits are designed for use in many different vehicle applications and it is the installer's responsibility to properly route and ensure adequate clearance and retention for brake hose components.
- Specified brake hose kits may not work with all Years, Makes and Models of vehicle that this brake kit is applicable to, due to possible OEM manufacturing changes during a production vehicle's life. It is the installer's responsibility to ensure that all fittings and hoses are the correct size and length, to ensure proper sealing and that they will not be subject to crimping, strain and abrasion from vibration or interference with suspension components, brake rotor or wheel.
- In absence of specific instructions for brake line routing, the installer must use his best professional judgment on correct routing and retention of lines to ensure safe operation. Test vehicle brake system per the 'minimum test' procedure stated within this document before driving. After road testing, inspect for leaks and interference. Initially after install and testing, perform frequent checks of the vehicle brake system and lines before driving, to confirm that there is no undue wear or interference not apparent from the initial test. Afterwards, perform periodic inspections for function, leaks and wear in a interval relative to the usage of vehicle.
- Repeat this entire procedure for the other wheel.
- Bleed the brake system. Reference the general information and recommendations below for proper bleeding instructions.
- Install the wheel and torque the lug nuts to manufacturer's specification. Check to see that the wheel rotates freely without interference.

## Balancing the Brake Bias on 4 Wheel Disc Vehicles

### •OE Style or Single Mount Race Pedal with Tandem Outlet Master Cylinder:

Front to rear caliper piston sizes, rotor diameters, and pad compounds must be initially configured to provide the correct range of vehicle bias when using a single bore / tandem outlet master cylinder. If excessive rear brake bias is experienced, an inline adjustable proportioning valve can be used to decrease the rear line pressure to help bring the vehicle into balance. If excessive front brake bias is experienced, first consideration should be given to increasing the rear brake bias to bring the vehicle into overall balance.

### •Race Pedal with Dual Master Cylinders and Balance Bar:

Master cylinders must be sized to match the calipers and allow the pedal balance bar to operate near the center of its travel. If it is not possible to fine tune the bias within the adjustable range of the balance bar, then consideration must be given to changing a master cylinder bore size or some other aspect of the brake system to bring the car into balance. Larger bore master cylinders will generate less pressure while decreasing pedal travel. Smaller bores master cylinders will generate higher line pressures with an increase in pedal travel.

## Additional Information and Recommendations

- Fill and bleed the new system with Wilwood Hi-Temp<sup>o</sup> 570 grade fluid or higher. For severe braking or sustained high heat operation, use Wilwood EXP 600 Plus Racing Brake Fluid. Used fluid must be completely flushed from the system to prevent contamination.

**NOTE:** *Silicone DOT 5 brake fluid is **NOT** recommended for racing or performance driving.*

- To properly bleed the brake system, begin with the caliper farthest from the master cylinder. Bleed the outboard bleed screw first, then the inboard. Repeat the procedure until all calipers in the system are bled, ending with the caliper closest to the master cylinder.

**NOTE:** *When using a new master cylinder, it is important to bench bleed the master cylinder first.*

- If the master cylinder is mounted lower than the disc brake calipers, some fluid flowback to the master cylinder reservoir may occur, creating a vacuum effect that retracts the caliper pistons into the housing. This will cause the pedal to go to the floor on the first stroke until it has “pumped up” and moved all the pistons out against the pad again. A Wilwood in-line two pound residual pressure valve, installed near the master cylinder will stop the fluid flowback and keep the pedal firm and responsive.

- Test the brake pedal. It should be firm, not spongy and stop at least 1 inch from the floor under heavy load.

If the brake pedal is spongy, bleed the system again.

If the brake pedal is initially firm, but then sinks to the floor, check the system for fluid leaks. Correct the leaks (if applicable) and then bleed the system again.

If the brake pedal goes to the floor and continued bleeding of the system does not correct the problem, a master cylinder with increased capacity (larger bore diameter) will be required. Wilwood offers various lightweight master cylinders with large fluid displacement capacities.

- Check your wheel offset before final assembly.

- On some models of disc brake spindles there are “ears” where the OEM calipers were mounted and these “ears” interfere with the assembly of the Wilwood disc brake kit. If it becomes necessary to remove these “ears”, remove as little as possible being careful not to cut away any of the mounting holes that may be required to bolt on the caliper mounting bracket.

- If after following the instructions, you still have difficulty in assembling or bleeding your Wilwood disc brakes, consult your local chassis builder, or retailer where the kit was purchased for further assistance.

## Brake Testing

### **WARNING • DO NOT DRIVE ON UNTESTED BRAKES BRAKES MUST BE TESTED AFTER INSTALLATION OR MAINTENANCE MINIMUM TEST PROCEDURE**

- Make sure pedal is firm: Hold firm pressure on pedal for several minutes, it should remain in position without sinking. If pedal sinks toward floor, check system for fluid leaks. DO NOT drive vehicle if pedal does not stay firm or can be pushed to the floor with normal pressure.
- At very low speed (2-5 mph) apply brakes hard several times while turning steering from full left to full right, repeat several times. Remove the wheels and check that components are not touching, rubbing, or leaking.
- Carefully examine all brake components, brake lines, and fittings for leaks and interference.
- Make sure there is no interference with wheels or suspension components.
- Drive vehicle at low speed (15-20 mph) making moderate and hard stops. Brakes should feel normal and positive. Again check for leaks and interference.
- Always test vehicle in a safe place where there is no danger to (or from) other people or vehicles.
- Always wear seat belts and make use of all safety equipment.

## Pad and Rotor Bedding

### **BEDDING STEPS FOR NEW PADS AND ROTORS – ALL COMPOUNDS**

Once the brake system has been tested and determined safe to operate the vehicle, follow these steps for the bedding of all new pad materials and rotors. These procedures should only be performed on a race track, or other safe location where you can safely and legally obtain speeds up to 65 MPH, while also being able to rapidly decelerate.

- Begin with a series of light decelerations to gradually build some heat in the brakes. Use an on-and-off the pedal technique by applying the brakes for 3-5 seconds, and then allow them to fully release for a period roughly twice as long as the deceleration cycle. If you use a 5 count during the deceleration interval, use a 10 count during the release to allow the heat to sink into the pads and rotors.
- After several cycles of light stops to begin warming the brakes, proceed with a series of medium to firm deceleration stops to continue raising the temperature level in the brakes.
- Finish the bedding cycle with a series of 8-10 hard decelerations from 55-65 MPH down to 25 MPH while allowing a proportionate release and heat-sinking interval between each stop. The pads should now be providing positive and consistent response.
- If any amount of brake fade is observed during the bed-in cycle, immediately begin the cool down cycle.
- Drive at a moderate cruising speed, with the least amount of brake contact possible, until most of the heat has dissipated from the brakes. Avoid sitting stopped with the brake pedal depressed to hold the car in place during this time. Park the vehicle and allow the brakes to cool to ambient air temperature.

### **COMPETITION VEHICLES**

- If your race car is equipped with brake cooling ducts, blocking them will allow the pads and rotors to warm up quicker and speed up the bedding process.
- Temperature indicating paint on the rotor and pad edges can provide valuable data regarding observed temperatures during the bedding process and subsequent on-track sessions. This information can be highly beneficial when evaluating pad compounds and cooling efficiencies.

## Pad and Rotor Bedding (Continued)

### POST-BEDDING INSPECTION – ALL VEHICLES

- After the bedding cycle, the rotors should exhibit a uniformly burnished finish across the entire contact face. Any surface irregularities that appear as smearing or splotching on the rotor faces can be an indication that the brakes were brought up to temperature too quickly during the bedding cycle. If the smear doesn't blend away after the next run-in cycle, or if chatter under braking results, sanding or resurfacing the rotors will be required to restore a uniform surface for pad contact.

### PRE-RACE WARM UP

- Always make every effort to get heat into the brakes prior to each event. Use an on-and-off the pedal practice to warm the brakes during the trip to the staging zone, during parade laps before the flag drops, and every other opportunity in an effort to build heat in the pads and rotors. This will help to ensure best consistency, performance, and durability from your brakes.

### DYNO BEDDED COMPETITION PADS AND ROTORS

- Getting track time for a proper pad and rotor bedding session can be difficult. Wilwood offers factory dyno-bedded pads and rotors on many of our popular competition pads and **Spec 37** GT series rotors. Dyno-bedded parts are ready to race on their first warm up cycle. This can save valuable time and effort when on-track time is either too valuable or not available at all, Dyno-bedding assures that your pads and rotors have been properly run-in and are ready to go. Contact your dealer or the factory for more information on Wilwood Dyno-Bedding services.

### **NOTE:**

*NEVER allow the contact surfaces of the pads or rotors to be contaminated with brake fluid. Always use a catch bottle with a hose to prevent fluid spill during all brake bleeding procedures.*