

ASSEMBLY INSTRUCTIONS
FOR
DYNALITE BIG BRAKE FRONT HAT KIT, 12.19" DIAMETER VENTED ROTOR
1990 - 1999 HONDA CIVIC (4 LUG)
FOR FACTORY 240 mm DISC SPINDLE

PART NUMBER GROUP

140-6310

**DISC BRAKES SHOULD ONLY BE INSTALLED BY
SOMEONE EXPERIENCED AND COMPETENT IN THE
INSTALLATION AND MAINTENANCE OF DISC BRAKES**
READ ALL WARNINGS



Photographic Tip

Important and highly recommended: Take photos of brake system before disassembly and during the disassembly process. In the event, trouble-shooting photos can be life savers. Many vehicles have undocumented variations, photos will make it much simpler for Wilwood to assist you if you have a problem.

Exploded Assembly Diagram

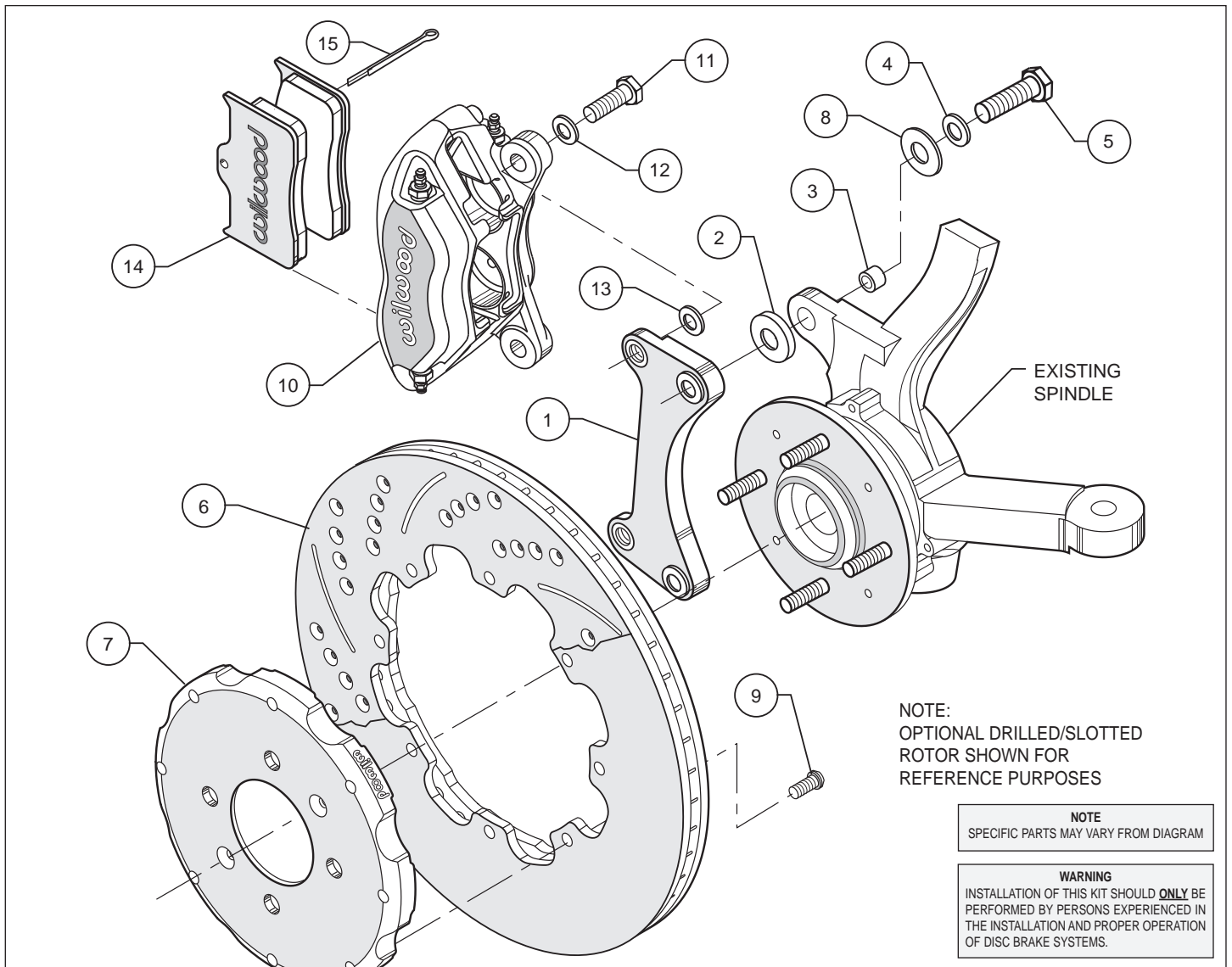

Figure 1. Typical Installation Configuration, Left Hand Application Shown

Parts List

ITEM NO.	PART NO.	DESCRIPTION	QTY
1	250-6290	Bracket, Caliper Mounting	2
2	240-6363	Spacer, .125 Thick	4
3	300-6347	Sleeve	4
4	240-11101	Washer, .453 I.D. x .750 O.D. x .063 Thick	4
5	230-9897	Bolt, 7/16-20 x 1.25 Long, Hex Head	4
6	160-5843	Rotor, UL, .81" Thk x 12.19" Dia, 8 x 7.00" Bolt Circle, Drilled & Slotted	2
6A	160-7103/04	Rotor, SRP, Drilled & Slotted	2
7	170-6288	Hat	2
8	240-1848	Shim, .03 Thick	8
9	230-11935	Bolt, 5/16-18 x 1.00 Long, Button Head, Torx	16
10	120-6806	Caliper, Forged Dynalite	2
10A	120-6806-RD	Caliper, Forged Dynalite, Red	2
11	230-10025	Bolt, 3/8-24 x 1.25 Long, Hex Head	4
12	240-10190	Washer, .391 I.D. x .625 O.D. x .063 Thick	4
13	240-1159	Shim, .035 thick	16
14	150-8850K	Pad, BP-10, Axle Set	1
15	180-0055S	Pin, Cotter	2
Optional	220-6419	Braided Stainless Steel Hose Kit (Not Included)	

NOTES:

Part Number 230-12177 Rotor Bolt Kit, includes part number 230-11935

Part Number 230-6364 Caliper Bracket Mounting Bolt Kit, includes P/N's 230-9897, 240-11101, 240-6363, 240-1848, and 300-6347

Part Number 230-11861 Caliper Mounting Bolt Kit, includes P/N's 230-10025, 240-10190 and 240-1159

Item 6A is an optional item and is included in the "-D" Kits, add "-D" to end of part number when ordering

Item 10A is an optional item and is included in the "-RD" Kits, add "-RD" to end of part number when ordering

General Information and Disassembly Instructions

Installation of this kit should **ONLY** be performed by persons experienced in the installation and proper operation of disc brake systems. Before installation begins, please read the complete procedure thoroughly to familiarize yourself with the process, and double check the following items to ensure a trouble-free installation.

- Make sure this is the correct kit to match the exact make and model year of the vehicle's spindle (i.e., brackets for a 1980 Honda spindle will not fit a 1997 Honda spindle).
- Verify the hat stud pattern in this kit matches the stud pattern of the vehicle's wheels.
- Verify your wheel clearance using Figure 2.
- Inspect the package contents against the parts list to ensure that all components and hardware are included.

Disassembly

- Disassemble the original equipment front brakes:

Raise the front wheels off the ground and support the front suspension according to the vehicle manufacturer's instructions.

Remove the wheel. Disconnect the caliper brake hose from the brake line at the body. Remove the two bolts that hold the stock caliper mounting bracket to the spindle. Lift off the bracket and stock caliper as one unit, then slide off the stock hat and rotor assembly. On some models you may have to unbolt the stock caliper from the caliper bracket before removal.

- Thoroughly clean the spindles.

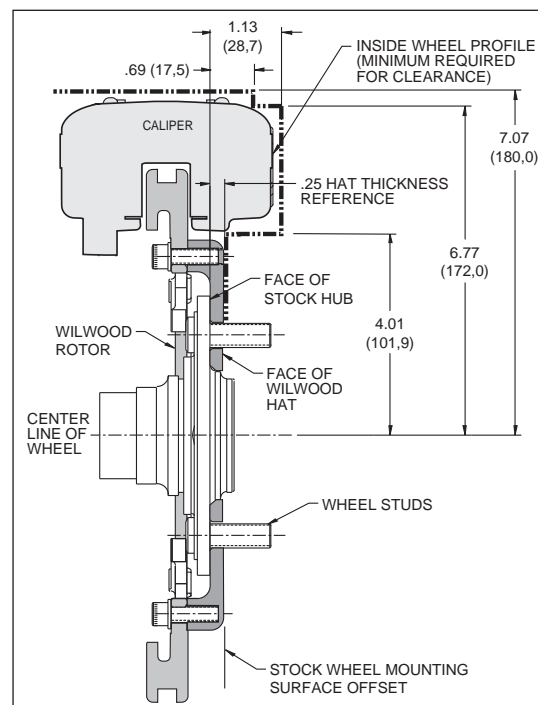

Figure 2. Wheel Clearance Diagram

Assembly Instructions

Assembly Instructions (numbers in parenthesis refer to the part list/diagram on the preceding pages): **CAUTION:** All mounting bolts must fully engage insert nuts. Be sure to check that all bolts are either flush or protruding through flanged side of insert nut after shimming.

- Insert one sleeve (3) each into the holes on the top and bottom of the spindle "ears" where the OEM caliper bracket was removed. Apply red *Loctite*® 271 to the mounting bolt threads (5) before installation of the caliper mounting bracket (1). Install the bracket with the flanged heads of the clinch nuts facing outboard, as shown in Figure 1. Slide bolt (5) through washer (4) and shim (8) into the previously installed sleeve (3) from the backside of the spindle. Position .125 thick spacer (2) between the spindle and the bracket. Torque bolts to 60 ft-lb.

- With the larger I.D. side of the rotor (6) facing away from the hat (7), attach rotor (6) to hat (7) using bolts (9) as shown in Figure 1. Using an alternating sequence, remove bolts (9) one at a time, apply red *Loctite*® 271 to the threads, and torque to 25 ft-lb.

- Slide the rotor/hat assembly onto the axle hub. Install three lug nuts (finger tighten) to keep the rotor/hat assembly in place while continuing with the installation.

- NOTE:** Please reference the caution statement at the beginning of the assembly instructions. Mount the caliper (10) onto the caliper mounting bracket (1) using two bolts (11) and two washers (12). View the rotor (6) through the top of the caliper (10). The rotor (6) should be aligned in the center of the caliper (10). If not, loosen the two bolts (11) and adjust the caliper (10) by using 0.035 inch thick shim washers (13). The shim washers (13) should be placed between the caliper (10) and the caliper mounting bracket (1). Finger tighten and recheck alignment. Add as many shim washers (13) as necessary to achieve the correct alignment. **NOTE:** The end of the bolt must be flush with or slightly protruding from the head of the clinch nut. See Figure 3. Place spare shims (13) between washer and caliper mounting ear to achieve the proper mounting fastener configuration. Always use the same amount of shims on both the top and bottom caliper mounting bolts (11). Loosen the two bolts (11) and apply red *Loctite*® 271 to bolt threads (11) and torque to 40 ft-lb.

- NOTE:** OEM rubber brake hoses generally cannot be adapted to Wilwood calipers. The caliper inlet fitting is a 1/8-27 NPT. The preferred method is to use steel adapter fittings at the caliper, either straight, 45 or 90 degree and enough steel braided line to allow for full suspension travel and turning radius, lock to lock. **Carefully route lines to prevent contact with moving suspension, brake or wheel components.** Wilwood hose kits are designed for use in many different vehicle applications and it is the installer's responsibility to properly route and ensure adequate clearance and retention for brake hose components.

- Specified brake hose kits may not work with all Years, Makes and Models of vehicle that this brake kit is applicable to, due to possible OEM manufacturing changes during a production vehicle's life. It is the installer's responsibility to ensure that all fittings and hoses are the correct size and length, to ensure proper sealing and that they will not be subject to crimping, strain and abrasion from vibration or interference with suspension components, brake rotor or wheel.

- In absence of specific instructions for brake line routing, the installer must use his best professional judgment on correct routing and retention of lines to ensure safe operation. Test vehicle brake system per the 'minimum test' procedure stated within this document before driving. After road testing, inspect for leaks and interference. Initially after install and testing, perform frequent checks of the vehicle brake system and lines before driving, to confirm that there is no undue wear or interference not apparent from the initial test. Afterwards, perform periodic inspections for function, leaks and wear in a interval relative to the usage of vehicle.

- Install the disc brake pads (14) and secure using cotter pin (15). Repeat this procedure for the other wheel.

- Bleed the brake system. Reference the general information and recommendations on page 5 for proper bleeding instructions.

- Remove the two lug nuts that were used to hold the rotor/hat assembly in place during caliper installation. Install the wheel and lug nuts, torque to OEM specifications.

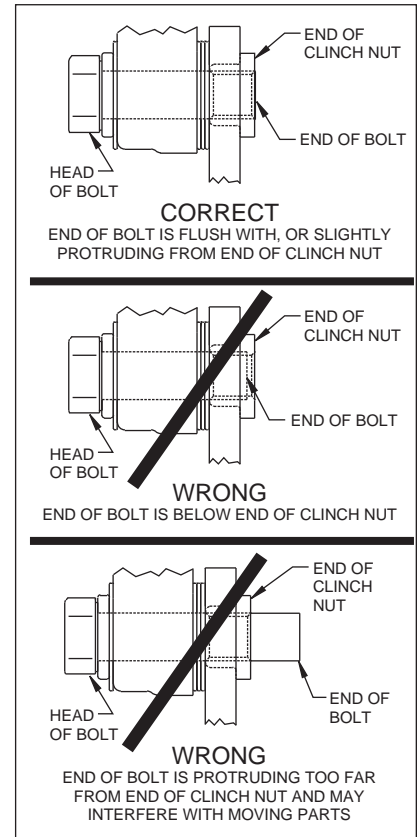

Additional Information and Recommendations

•**NOTE:** *With the installation of after market disc brakes, the wheel track may change depending on the application. Check your wheel offset before final assembly.*

•Please read the following concerning balancing the brake bias on 4 wheel disc vehicles.

This brake kit can be operated using the stock OEM master cylinder. However, as with most suspension and tire modifications (from OEM specifications), changing the brakes may alter the front to rear brake bias. Rear brakes should not lock up before the front. Brake system evaluation and tests should be performed by persons experienced in the installation and proper operation of brake systems. Evaluation and tests should be performed under controlled conditions. Start by making several stops from low speeds then gradually work up to higher speeds. Always utilize safety restraint systems while operating vehicle.

Use a Wilwood adjustable proportioning valve if necessary to achieve proper brake balance, or

Use a Wilwood brake pedal/balancebar assembly with dual master cylinders (requires custom mounting as used in fabricated chassis race cars). A balance bar brake system permits incremental front to rear brake pressure adjustments.

•For optimum performance, fill and bleed the new system with Wilwood Hi-Temp^o 570 grade fluid or EXP 600 Plus. For severe braking or sustained high heat operation, use Wilwood EXP 600 Plus Racing Brake Fluid. Used fluid must be completely flushed from the system to prevent contamination. **NOTE:** *Silicone DOT 5 brake fluid is **NOT** recommended for racing or performance driving.*

•To properly bleed the brake system, begin with the caliper farthest from the master cylinder. Bleed the outboard bleed screw first, then the inboard. Repeat the procedure until all calipers in the system are bled, ending with the caliper closest to the master cylinder. If the caliper is fitted with bleed screws on four corners, make sure the bottom bleed screws are tight. Only bleed from the top bleed screws. **NOTE:** *When using a new master cylinder, it is important to bench bleed the master cylinder first.*

•If the master cylinder is mounted lower than the disc brake calipers, some fluid flowback to the master cylinder reservoir may occur, creating a vacuum effect that retracts the caliper pistons into the housing. This will cause the pedal to go to the floor on the first stroke until it has "pumped up" and moved all the pistons out against the pad again. A Wilwood in-line 2 lb. Residual Pressure Valve installed near the master cylinder will stop the fluid flowback and keep the pedal firm and responsive.

•Test the brake pedal. It should be firm, not spongy, and stop at least 1 inch from the floor under heavy load.

If the brake pedal is spongy, bleed the system again.

If the brake pedal is initially firm, but then sinks to the floor, check the system for leaks. Correct the leaks (if applicable) and then bleed the system again.

If the brake pedal goes to the floor and continued bleeding of the system does not correct the problem, either air may be trapped in the system, or a master cylinder with increased capacity (larger bore diameter) may be required. Wilwood offers various lightweight master cylinders with large fluid displacement capacities (custom fabricated mounting may be required).

•On some models of disc brake spindles there are "ears" where the OEM calipers were mounted that interfere with the assembly of the Wilwood disc brake kit. If "ear" removal is required, remove only what is necessary to clear the new bracket, retaining appropriate mounting bolt holes.

Brake Testing

WARNING • DO NOT DRIVE ON UNTESTED BRAKES BRAKES MUST BE TESTED AFTER INSTALLATION OR MAINTENANCE MINIMUM TEST PROCEDURE

- Make sure pedal is firm: Hold firm pressure on pedal for several minutes, it should remain in position without sinking. If pedal sinks toward floor, check system for fluid leaks. DO NOT drive vehicle if pedal does not stay firm or can be pushed to the floor with normal pressure.
- At very low speed (2-5 mph) apply brakes hard several times while turning steering from full left to full right, repeat several times. Remove the wheels and check that components are not touching, rubbing, or leaking.
- Carefully examine all brake components, brake lines, and fittings for leaks and interference.
- Make sure there is no interference with wheels or suspension components.
- Drive vehicle at low speed (15-20 mph) making moderate and hard stops. Brakes should feel normal and positive. Again check for leaks and interference.
- Always test vehicle in a safe place where there is no danger to (or from) other people or vehicles.
- Always wear seat belts and make use of all safety equipment.

Pad and Rotor Bedding

BEDDING STEPS FOR NEW PADS AND ROTORS – ALL COMPOUNDS

Once the brake system has been tested and determined safe to operate the vehicle, follow these steps for the bedding of all new pad materials and rotors. These procedures should only be performed on a race track, or other safe location where you can safely and legally obtain speeds up to 65 MPH, while also being able to rapidly decelerate.

- Begin with a series of light decelerations to gradually build some heat in the brakes. Use an on-and-off the pedal technique by applying the brakes for 3-5 seconds, and then allow them to fully release for a period roughly twice as long as the deceleration cycle. If you use a 5 count during the deceleration interval, use a 10 count during the release to allow the heat to sink into the pads and rotors.
- After several cycles of light stops to begin warming the brakes, proceed with a series of medium to firm deceleration stops to continue raising the temperature level in the brakes.
- Finish the bedding cycle with a series of 8-10 hard decelerations from 55-65 MPH down to 25 MPH while allowing a proportionate release and heat-sinking interval between each stop. The pads should now be providing positive and consistent response.
- If any amount of brake fade is observed during the bed-in cycle, immediately begin the cool down cycle.
- Drive at a moderate cruising speed, with the least amount of brake contact possible, until most of the heat has dissipated from the brakes. Avoid sitting stopped with the brake pedal depressed to hold the car in place during this time. Park the vehicle and allow the brakes to cool to ambient air temperature.

COMPETITION VEHICLES

- If your race car is equipped with brake cooling ducts, blocking them will allow the pads and rotors to warm up quicker and speed up the bedding process.
- Temperature indicating paint on the rotor and pad edges can provide valuable data regarding observed temperatures during the bedding process and subsequent on-track sessions. This information can be highly beneficial when evaluating pad compounds and cooling efficiencies.

Pad and Rotor Bedding (Continued)

POST-BEDDING INSPECTION – ALL VEHICLES

- After the bedding cycle, the rotors should exhibit a uniformly burnished finish across the entire contact face. Any surface irregularities that appear as smearing or splotching on the rotor faces can be an indication that the brakes were brought up to temperature too quickly during the bedding cycle. If the smear doesn't blend away after the next run-in cycle, or if chatter under braking results, sanding or resurfacing the rotors will be required to restore a uniform surface for pad contact.

PRE-RACE WARM UP

- Always make every effort to get heat into the brakes prior to each event. Use an on-and-off the pedal practice to warm the brakes during the trip to the staging zone, during parade laps before the flag drops, and every other opportunity in an effort to build heat in the pads and rotors. This will help to ensure best consistency, performance, and durability from your brakes.

DYNO BEDDED COMPETITION PADS AND ROTORS

- Getting track time for a proper pad and rotor bedding session can be difficult. Wilwood offers factory dyno-bedded pads and rotors on many of our popular competition pads and **Spec 37** GT series rotors. Dyno-bedded parts are ready to race on their first warm up cycle. This can save valuable time and effort when on-track time is either too valuable or not available at all, Dyno-bedding assures that your pads and rotors have been properly run-in and are ready to go. Contact your dealer or the factory for more information on Wilwood Dyno-Bedding services.

NOTE:

NEVER allow the contact surfaces of the pads or rotors to be contaminated with brake fluid. Always use a catch bottle with a hose to prevent fluid spill during all brake bleeding procedures.