

ASSEMBLY INSTRUCTIONS
FOR
COMBINATION PARKING BRAKE (CPB) CALIPER REAR
BRAKE KIT WITH 12.90" DIAMETER VENTED ROTOR

2000 - 2005 HONDA S2000

PART NUMBER GROUP

140-10310

**DISC BRAKES SHOULD ONLY BE INSTALLED BY SOMEONE
EXPERIENCED AND COMPETENT IN THE INSTALLATION AND
MAINTENANCE OF DISC BRAKES
READ ALL WARNINGS**



Photographic Tip

Important and highly recommended: Take photos of brake system before disassembly and during the disassembly process. In the event, trouble-shooting photos can be life savers. Many vehicles have undocumented variations, photos will make it much simpler for Wilwood to assist you if you have a problem.

Exploded Assembly Diagram

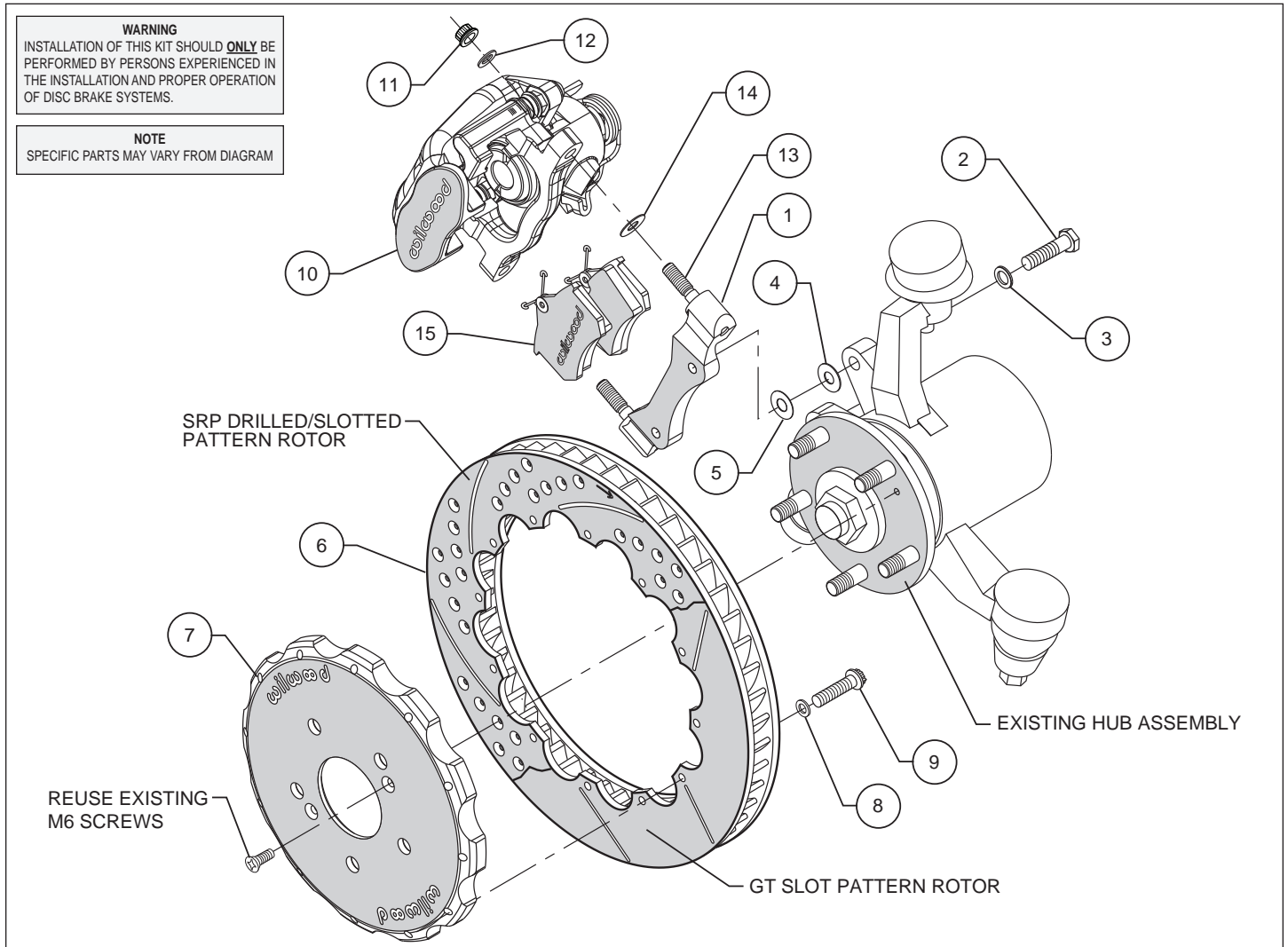

Figure 1. Typical Installation Configuration

Parts List

| ITEM NO. | PART NO. | DESCRIPTION | QTY |
|----------|-----------------|--|-----|
| 1 | 250-10298 | Bracket, Caliper Mounting | 2 |
| 2 | 230-10022 | Bolt, 3/8-16 x 1.50 Long, Hex Head | 4 |
| 3 | 240-10190 | Washer, .391 I.D. x .625 O.D. x .063 Thick | 4 |
| 4 | 240-10306 | Shim, .016 Thick | 4 |
| 5 | 240-1159 | Shim, .035 Thick | 16 |
| 6 | 160-9959/60 | Rotor, GT .81" X 12.90" Dia, 12 x 8.75" Bolt Circle (one each, right and left) | 2 |
| 6A | 160-9961/62 | Rotor, SRP Drilled and Slotted (one each, right and left) | 2 |
| 7 | 170-10295 | Hat, 5 x 4.50, .543 Offset, 12 x 8.75" Bolt Circle | 2 |
| 8 | 240-11240 | Washer, .265 I.D. x .500 O.D. x .063 Thick | 24 |
| 9 | 230-6737 | Bolt, 1/4-20 x 1.00 Long, 12 Point | 24 |
| 10 | 120-10112/13-BK | Caliper, CPB, 41 mm (one each, right and left) | 2 |
| 11 | 230-9183 | Nut, 3/8-24, Self-Locking, 12 Point | 4 |
| 12 | 240-10190 | Washer, .391 I.D. x .625 O.D. x .063 Thick | 4 |
| 13 | 230-9078 | Stud, 3/8-16 x 3/8-24 x 2.50 long (pre installed in bracket) | 4 |
| 14 | 240-1159 | Shim, .035 Thick | 8 |
| 15 | 150-9184K | Pad, BP-10, Axle Set | 1 |

NOTES: Part Number 230-4572 Rotor Bolt Kit, includes P/N 230-6737 and 240-11240

Part Number 230-10312 Bracket Bolt Kit, includes P/N 230-10022, 240-10190, 240-10306 and 240-1159

Part Number 250-10311 Caliper Bracket Kit, includes P/N 250-10298, 230-9078, 230-9183, 240-1159 and 240-10190

Item 6A is an optional item and is included with the "-D" kits. Add "-D" to end of part number when ordering

Wilwood offers an optional Braided Stainless Steel Hose Kit. Order part number 220-10840 (not included in kit).

Parking brake cable kit is required for functionality. Order part number 330-10805 (not included in kit).

General Information and Disassembly Instructions

- Installation of this kit should **ONLY** be performed by individuals experienced in the installation and proper operation of disc brake systems. Prior to any attempt to install this kit, please check the following to ensure a trouble free installation.

- Inspect the contents of this kit against the parts list to ensure that all components and hardware are included.

- Make sure this is the correct kit to fit the exact make and model year of your axle. This kit is designed for direct bolt-on installation to 2000 through 2005 model year Honda S2000.

- Verify your wheel clearance using Figure 2.

- Verify that the factory axle and stud pattern matches the stud hole pattern in the hats supplied with this kit. Axles that have been modified with different size studs or lug patterns may require modifications to the hat that must be performed by a qualified machinist.

Disassembly

- Disassemble the original equipment rear brakes: Raise the rear wheels off the ground and support the rear suspension according to the vehicle manufacturer's instructions.

- Remove the wheel. Loosen the bolts from the outboard side of the upright that holds the stock caliper mounting bracket and lift off the bracket and stock caliper as one unit. You may have to unbolt the stock caliper from the caliper bracket before removal. Then slide off the rotor.

- Clean, de-grease the stock hub while removing any nicks or burrs.

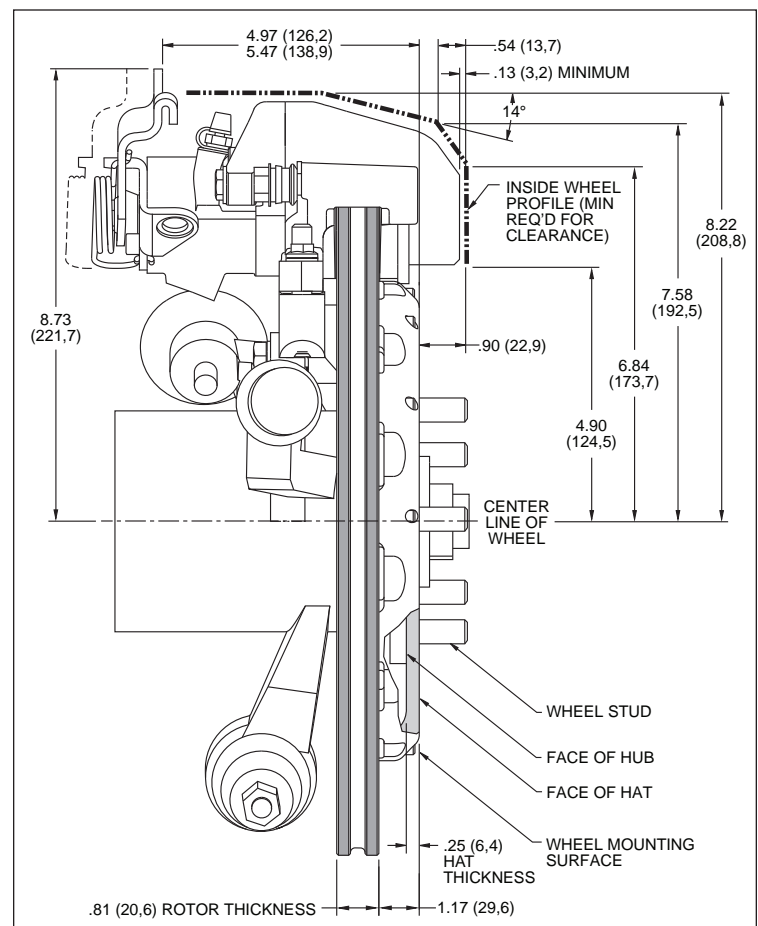

Figure 2. Wheel Clearance Diagram

Assembly Instructions

IMPORTANT:

- To ensure maximum performance from your parking brake system, the cables must be routed as straight as possible. Bends in the cable can significantly reduce efficiency and thus reduce pull force at the brake. Tight bends must be avoided with a minimum recommended bend radius of 6" to 8".
- Cables should be properly restrained to prevent "straightening" of bends when tension is applied. Restrain movement of cable by affixing the cable sheath to body or chassis by fitting cable clamps at various points over the length of cable or by using original equipment cable attachments points. The clamping method chosen will require that cable sheath be held tightly without movement, crushing or causing interference to the internal cable.
- Cables must be initially pre-stretched by multiple applications of the brake handle, then re-adjusted to correct tension.

Assembly Instructions (numbers in parenthesis refer to the part list/diagram on the preceding page):

- The caliper mounting bracket (1) should be installed first with clean, dry threads on the mounting bolts. Install the bracket (1) on the outboard side of the hub assembly by sliding bolt (2) from the inboard side of the hub assembly through washer (3) through the existing OEM caliper mounting holes and thread into caliper mounting bracket (1) (see figure 1). Place one shim washer (4) and one shim washer (5) between the hub assembly and the caliper mounting bracket (1). The mounting bracket (1) must tighten squarely against the outboard side of the hub assembly face. Inspect for interference from casting irregularities, machining ridges, burrs, etc. Use one shim washer (4) and one shim (5) between the mounting bracket (1) and the hub assembly during initial trial fitting.

- With the larger I.D. side of the rotor (6) facing away from the hat (7), bolt rotor (6) to hat (7) through the backside of the rotor using washers (8), and bolts (9). -Using an alternating sequence, apply red *Loctite*® 271 to the threads and torque bolts to 155 in-lb. For an added measure of security, the bolts may be safety wired using standard 0.032 inch diameter stainless steel safety wire as shown in Figure 3. Please refer to Wilwood's data sheet DS-386 for complete safety wire installation instructions.

- Install the hat and rotor (6 and 7) assembly onto the hub. Check to be sure the hat seats squarely against the hub. The hub must be free from any rust, debris, casting burrs, machining irregularities, etc. Use several lug nuts to hold the rotor and hat firmly against the hub during the next phases of the installation and clearance checking procedures.

- Slide the brake pads (15) up into the caliper (10) from the bottom until the "v" spring clip snaps into place against the anvil. They should install easily without interference.

- Lubricate caliper mounting studs and nuts with lightweight oil. Install two shims (14) over each stud (13) on the radial mount bracket (1). Slide the caliper (10) in place over the studs and rotor and install the washer (12) and lock nut (11) to hold the caliper in place. The caliper bleed screw should be pointing toward the front of the vehicle. Snug the lock nuts (11) and check that the caliper (10) is centered over the rotor (6). Add or subtract .016" shims (4) and/or .035" shims (5) as necessary between the caliper mounting bracket (1) and the spindle face to center the caliper (10) on the rotor (6).

- Check that the outside radius of the brake pad (15) is aligned with the outside diameter radius of the rotor face. Add or subtract shims (14) between the caliper (10) and the caliper mounting bracket (1) to gain the proper alignment.

- Remove the lug nuts that were holding the hat/rotor in place. Install the wheel and torque the lug nuts to manufacturer's specification. Check to see that the wheel rotates freely without interference.

- Once all clearances have been checked, remove the wheel, caliper and rotor from the axle flange. Secure the caliper mounting bracket (1) to the spindle face while applying red *Loctite*® 271 on the bolt threads (2). Torque the bolts (2) to 22 ft-lbs. Reinstall the rotor and again use several lug nuts to hold it in place being sure to align the small countersunk holes in the hat (7) with the corresponding holes in the hub. Reinstall the caliper, torque the caliper nuts (11) to 30 ft-lbs.

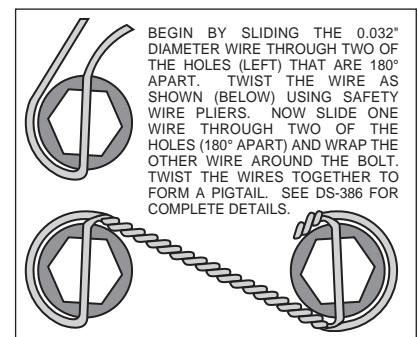

Figure 3. Safety Wire Diagram

Assembly Instructions (Continued)

- **NOTE:** OEM rubber brake hoses generally cannot be adapted to Wilwood calipers. The caliper inlet fitting is M10 x 1.0 banjo. The preferred method is to use banjo fittings at the caliper with enough steel braided line to allow for full suspension travel. **Carefully route lines to prevent contact with moving suspension, brake or wheel components.** Wilwood hose kits are designed for use in many different vehicle applications and it is the installer's responsibility to properly route and ensure adequate clearance and retention for brake hose components. Wilwood offers a hose kit, P/N 220-10804, which includes hoses, fittings, etc., all in one package for this application.
- Specified brake hose kits may not work with all Years, Makes and Models of vehicle that this brake kit is applicable to, due to possible OEM manufacturing changes during a production vehicle's life. It is the installer's responsibility to ensure that all fittings and hoses are the correct size and length, to ensure proper sealing and that they will not be subject to crimping, strain and abrasion from vibration or interference with suspension components, brake rotor or wheel.
- In absence of specific instructions for brake line routing, the installer must use his best professional judgment on correct routing and retention of lines to ensure safe operation. Test vehicle brake system per the 'minimum test' procedure stated within this document before driving. After road testing, inspect for leaks and interference. Initially after install and testing, perform frequent checks of the vehicle brake system and lines before driving, to confirm that there is no undue wear or interference not apparent from the initial test. Afterwards, perform periodic inspections for function, leaks and wear in a interval relative to the usage of vehicle.
- Repeat this entire procedure for the other wheel.
- Bleed the brake system. Reference the general information and recommendations on page 6 for proper bleeding instructions.
- Parking brake cable kit, P/N 330-10805 (not included in kit, must order separately) is required for parking brake functionality. Please follow the instruction in DS-657 (available at www.wilwood.com/pdf/ds657.pdf) for installation procedure.
- Remove the lug nuts that were used to hold the hat/rotor assembly in place during caliper installation. Reinstall the two OEM countersunk set screws through the small holes in the hat (7) and torque to manufacturers specifications. Check to be sure the hat seats squarely against the hub. Install the wheel and torque the lug nuts to manufacturers specifications.

Additional Information and Recommendations

•**NOTE:** *With the installation of after market disc brakes, the wheel track may change depending on the application. Check your wheel offset before final assembly.*

•Please read the following concerning balancing the brake bias on 4 wheel disc vehicles.

This Honda rear brake kit can be operated using the stock OEM master cylinder. However, as with most suspension and tire modifications (from OEM specifications), changing the brakes may alter the front to rear brake bias. Rear brakes should not lock up before the front. Brake system evaluation and tests should be performed by persons experienced in the installation and proper operation of brake systems. Evaluation and tests should be performed under controlled conditions. Start by making several stops from low speeds then gradually work up to higher speeds. Always utilize safety restraint systems while operating vehicle.

•For optimum performance, fill and bleed the new system with Wilwood Hi-Temp° 570 grade fluid or EXP 600 Plus. For severe braking or sustained high heat operation, use Wilwood EXP 600 Plus Racing Brake Fluid. Used fluid must be completely flushed from the system to prevent contamination. **NOTE:** *Silicone DOT 5 brake fluid is **NOT** recommended for racing or performance driving.*

•To properly bleed the brake system, begin with the caliper farthest from the master cylinder. Bleed the outboard bleed screw first, then the inboard. Repeat the procedure until all calipers in the system are bled, ending with the caliper closest to the master cylinder. If the caliper is fitted with bleed screws on four corners, make sure the bottom bleed screws are tight. Only bleed from the top bleed screws. **NOTE:** *When using a new master cylinder, it is important to bench bleed the master cylinder first.*

•Test the brake pedal. It should be firm, not spongy, and stop at least 1 inch from the floor under heavy load.
If the brake pedal is spongy, bleed the system again.

If the brake pedal is initially firm, but then sinks to the floor, check the system for leaks. Correct the leaks (if applicable) and then bleed the system again.

If the brake pedal goes to the floor and continued bleeding of the system does not correct the problem, either air may be trapped in the system, or a master cylinder with increased capacity (larger bore diameter) may be required. Wilwood offers various lightweight master cylinders with large fluid displacement capacities (custom fabricated mounting may be required).

Brake Testing

WARNING • DO NOT DRIVE ON UNTESTED BRAKES BRAKES MUST BE TESTED AFTER INSTALLATION OR MAINTENANCE MINIMUM TEST PROCEDURE

- Make sure pedal is firm: Hold firm pressure on pedal for several minutes, it should remain in position without sinking. If pedal sinks toward floor, check system for fluid leaks. **DO NOT** drive vehicle if pedal does not stay firm or can be pushed to the floor with normal pressure.
- At very low speed (2-5 mph) apply brakes hard several times while turning steering from full left to full right, repeat several times. Remove the wheels and check that components are not touching, rubbing, or leaking.
- Carefully examine all brake components, brake lines, and fittings for leaks and interference.
- Make sure there is no interference with wheels or suspension components.
- Drive vehicle at low speed (15-20 mph) making moderate and hard stops. Brakes should feel normal and positive. Again check for leaks and interference.
- Always test vehicle in a safe place where there is no danger to (or from) other people or vehicles.
- Always wear seat belts and make use of all safety equipment.

Pad and Rotor Bedding

BEDDING STEPS FOR NEW PADS AND ROTORS – ALL COMPOUNDS

Once the brake system has been tested and determined safe to operate the vehicle, follow these steps for the bedding of all new pad materials and rotors. These procedures should only be performed on a race track, or other safe location where you can safely and legally obtain speeds up to 65 MPH, while also being able to rapidly decelerate.

- Begin with a series of light decelerations to gradually build some heat in the brakes. Use an on-and-off the pedal technique by applying the brakes for 3-5 seconds, and then allow them to fully release for a period roughly twice as long as the deceleration cycle. If you use a 5 count during the deceleration interval, use a 10 count during the release to allow the heat to sink into the pads and rotors.
- After several cycles of light stops to begin warming the brakes, proceed with a series of medium to firm deceleration stops to continue raising the temperature level in the brakes.
- Finish the bedding cycle with a series of 8-10 hard decelerations from 55-65 MPH down to 25 MPH while allowing a proportionate release and heat-sinking interval between each stop. The pads should now be providing positive and consistent response.
- If any amount of brake fade is observed during the bed-in cycle, immediately begin the cool down cycle.
- Drive at a moderate cruising speed, with the least amount of brake contact possible, until most of the heat has dissipated from the brakes. Avoid sitting stopped with the brake pedal depressed to hold the car in place during this time. Park the vehicle and allow the brakes to cool to ambient air temperature.

COMPETITION VEHICLES

- If your race car is equipped with brake cooling ducts, blocking them will allow the pads and rotors to warm up quicker and speed up the bedding process.
- Temperature indicating paint on the rotor and pad edges can provide valuable data regarding observed temperatures during the bedding process and subsequent on-track sessions. This information can be highly beneficial when evaluating pad compounds and cooling efficiencies.

POST-BEDDING INSPECTION – ALL VEHICLES

- After the bedding cycle, the rotors should exhibit a uniformly burnished finish across the entire contact face. Any surface irregularities that appear as smearing or splotching on the rotor faces can be an indication that the brakes were brought up to temperature too quickly during the bedding cycle. If the smear doesn't blend away after the next run-in cycle, or if chatter under braking results, sanding or resurfacing the rotors will be required to restore a uniform surface for pad contact.

PRE-RACE WARM UP

- Always make every effort to get heat into the brakes prior to each event. Use an on-and-off the pedal practice to warm the brakes during the trip to the staging zone, during parade laps before the flag drops, and every other opportunity in an effort to build heat in the pads and rotors. This will help to ensure best consistency, performance, and durability from your brakes.

DYNO BEDDED COMPETITION PADS AND ROTORS

- Getting track time for a proper pad and rotor bedding session can be difficult. Wilwood offers factory dyno-bedded pads and rotors on many of our popular competition pads and **Spec 37** GT series rotors. Dyno-bedded parts are ready to race on their first warm up cycle. This can save valuable time and effort when on-track time is either too valuable or not available at all, Dyno-bedding assures that your pads and rotors have been properly run-in and are ready to go. Contact your dealer or the factory for more information on Wilwood Dyno-Bedding services.

NOTE:

NEVER allow the contact surfaces of the pads or rotors to be contaminated with brake fluid. Always use a catch bottle with a hose to prevent fluid spill during all brake bleeding procedures.

Parking Brake

WARNING • PARKING BRAKE

- Parking brake must be properly adjusted before use and must be manually readjusted for wear if parking brake handle or foot lever travel becomes excessive.
 - The holding ability of the brake should be tested by stopping on a sloping surface and applying the parking brake while holding car with the hydraulic foot brake. This should be accomplished both facing up and down hill.
 - Do not rely exclusively on the parking brake to hold the car; Curb wheels as recommended by the applicable diagram and put gear selector in park, or shift into first gear or reverse with a manual transmission.
-
- Diagram A - When parking facing downhill, turn front wheels towards the curb or right shoulder. This will keep from rolling into traffic if the brakes become disengaged.
 - Diagram B - Turn the steering wheel to the left so the wheels are turned towards the road if you are facing uphill with a curb. The tires will catch the curb if the car rolls backward.
 - Diagram C - When facing uphill without a curb, turn the wheels sharply to the right. If the vehicle rolls, it will go off the road rather than into traffic.
 - When parking on a hill, always set the parking brake and move the gear selector into park, or shift into first or reverse gear if your vehicle has a manual transmission.

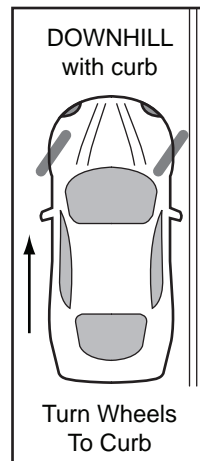

Diagram A

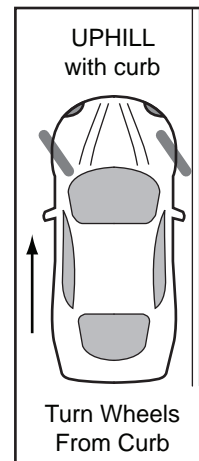

Diagram B

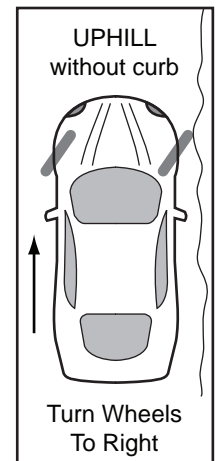

Diagram C