



# IRON GM METRIC CALIPER

## Caliper Highlights:

These all new cast, not rebuilt iron calipers are bolt-on replacements for the popular 1978 and later **GM Metric** calipers that are widely used in "spec" racing categories and low cost disc brake conversions. The availability of good used or rebuilt OE calipers is on the decline, and there are limited options for piston sizes in the stock calipers.

Wilwood iron **GM Metric** calipers combine new part quality with modern machining precision. There are two piston size options to assist builders with properly building static bias into a car. Previously, builders using the metric calipers generally had to mount the same size calipers on all four wheels. This drastically limited the tuning options and often created front to rear bias ratios that were not conducive to good handling and stability under hard braking. Some builders, and other brake suppliers, chose to offer re-machined OE calipers to provide a bias tuning option. Unfortunately, re-machining a used casting that was never designed for the larger bore size, can create real compromises in strength, reliability, and performance.



To address these needs, Wilwood has tooled two separate new castings that are fitted with either 2.75" or 2.00" stainless steel pistons and high temperature bore seals. Each casting is designed specific for its intended bore size, and simply not over machined to accept different pistons. The calipers are strong and precise, without unnecessary added weight from oversized castings. The stainless steel pistons resist corrosion in all environments while helping to slow the heat transfer from the pads. The high temperature seals provide long service life when used in hard braking applications and maintain their resilience to provide positive piston retraction on release. In addition to the optional piston sizes, two models are available with slide pin vibration dampers installed to help reduce rattle and other harsh noise.

All Wilwood **GM Metric** Calipers use the standard D154 type brake pads. The complete range of Wilwood high performance and racing pad compounds is available to match response, friction, and temperature range to any application.

## ORDERING INFORMATION:

<b>BORE SIZE</b>		<b>DISC WIDTH</b>		<b>WEIGHT (LBS)</b>	<b>PART NUMBER</b> (1,2)
2.75"	69,9 mm	1.00"	24,4 mm	4.4	120-8924
2.75"	69,9 mm	1.00"	25,4 mm	4.4	120-8926 <sup>(3)</sup>
2.00"	50,8 mm	1.00"	25,4 mm	4.1	120-9333
2.00"	50,8 mm	1.00"	25,4 mm	4.1	120-9487 <sup>(3)</sup>

### NOTES:

- (1) THE CALIPER PART NUMBERS ARE THE SAME FOR LEFT OR RIGHT MOUNTING. BLEED SCREW AND INLET FITTINGS MUST BE INSTALLED IN THE CORRECT POSITION DURING ASSEMBLY ON THE VEHICLE.
- (2) CALIPER SLIDE PIN BOLTS, PART NUMBER 230-0619 ARE REQUIRED FOR INSTALLATION AND MUST BE ORDERED SEPARATELY. EACH KIT CONTAINS FOUR BOLTS.
- (3) THESE CALIPERS INCLUDE SLIDE PIN VIBRATION DAMPERS

### IRON GM METRIC CALIPER, MOUNTING DIMENSIONS:

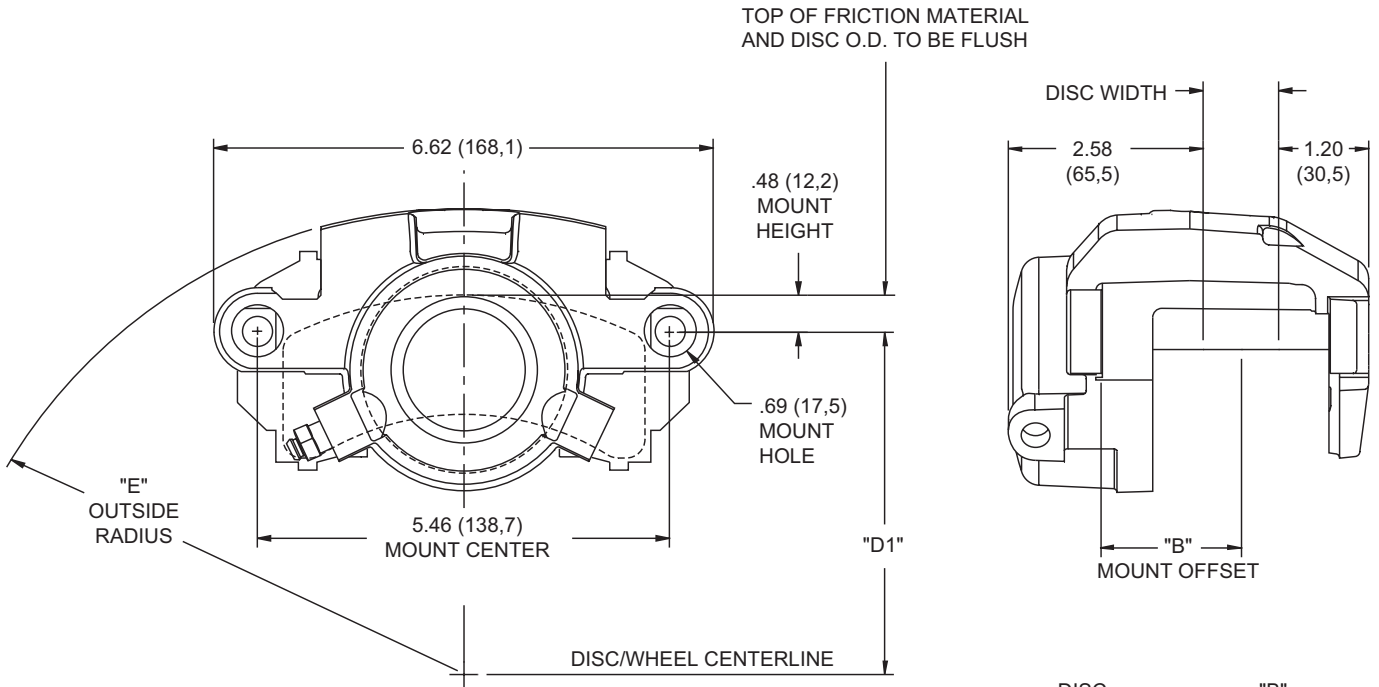

DIMENSION "D1" = (DISC DIAMETER/2) - .48 (12,2)  
 CALIPER MOVES INWARD AS PAD WEARS, .35 (8,9) MAX

NOTE: RIGHT HAND CALIPER SHOWN, LEFT HAND HAS BLEED SCREW REVERSED

INLET FITTING: M10 x 1.5

DISC WIDTH	"B" MOUNT OFFSET
1.00 (25,4)	1.85 (47,0)

DISC DIAMETER	"E" OUTSIDE RADIUS
11.00 (279,4)	6.55 (166,4)
11.75 (298,5)	6.90 (175,3)

### IRON GM METRIC CALIPER TYPE D154 PAD DIMENSIONS AND ORDERING INFORMATION:

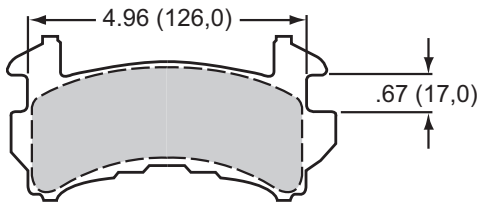

INNER PAD ABOVE, OUTER BELOW

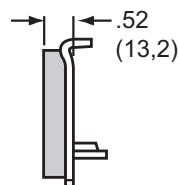
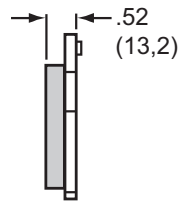
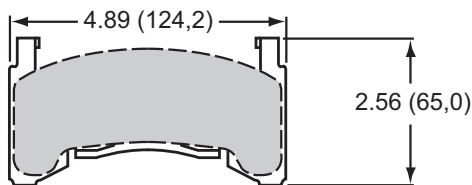

#### AXLE SET P/N

15A - 6219K  
 15B - 3998K  
 15C - 4420K  
 15E - 6103K  
 15H - 8231K  
 15Q - 6831K  
 150 - 8936K  
 150 - 9422K

#### PAD TYPE / COMPOUND

D154 A PolyMatrix  
 D154 B PolyMatrix  
 D154 C PolyMatrix  
 D154 E PolyMatrix  
 D154 H PolyMatrix  
 D154 Q PolyMatrix  
 D154 10 BP-10 Smart Pad  
 D154 20 BP-20 Smart Pad

### ORDERING INFORMATION: USER SERVICEABLE COMPONENTS:

CALIPER PART NO.	PISTON	O-RING KIT (4 PK)	BLEED SCREW KIT (EA)	SLIDE PIN KIT (4 PK)
120-8924	200-6633 (2.75")	130-4955	220-8932	230-0619
120-8926	200-6633 (2.75")	130-4955	220-8932	230-0619
120-9333	200-9342 (2.00")	130-0777	220-8932	230-0619
120-9487	200-9342 (2.00")	130-0777	220-8932	230-0619