



BILLET POWERLITE CALIPER

Caliper Highlights:

The **Powerlite** four piston radial mount caliper combines pure race technology with a new generation of Wilwood performance enhancements. Its sleek profile, superior strength, and durability in higher temperature applications are easily adapted to a wide range of sports, rally, and off road driving applications.



The strength of the **Powerlite** is a combination of process and design. The process of stress-flow forging re-aligns the metal's grain structure within the contour of the caliper body. This eliminates the stresses and interruptions to the internal grain structure that occur when machining a straight block billet. The FEA generated radial transition design eliminates steps and shoulders in the area between the piston housing body and the caliper bridges. Incorporating a radius in this critical area substantially increases resistance to deflection and caliper separation under load. Structural deflection and volume displacement tests have proven the efficiency of this innovative design. Without even considering the overall greater strength and reliability of the billet forging, the reduction in overall deflection and fluid volume displacement translate to increased clamping efficiency with less pedal travel. The bottom line is a firm pedal with outstanding stopping power.

The superior strength of this innovative design is combined with a new generation of Wilwood performance features. The **Powerlite** uses a new 7912 type brake pad that is supported from the top by Quick-clip pad retainers. This feature eliminates the need for a pad support step in the bottom of the caliper and adds additional clearance for mounting closer to the hub on small wheel and small rotor applications. The pad radius matches to rotor diameters between 9.45" (240,0 mm) and 11.00" (279,4 mm), and the caliper fits easily inside many 13.00" (330,2) wheel applications. The Quick-Clips also accommodate easy pad access without caliper removal. Brake pad compounds are available to cover the full range of sport and competition applications.

Every caliper is equipped with Wilwood's SRS stainless steel bridge plates. The SRS plates eliminate the bridge wear caused by pad gouging and extend the service life of the caliper body. The spring-loading action of the SRS plates also eliminates pad rattle and dampens the vibration harmonics that contribute to squeal under braking. Internal fluid passages eliminate the need for external tubes. Four corner bleed screws assure simple and effective air evacuation from the system and allow one caliper to be mounted in any front, rear, right or left position

ORDERING INFORMATION:

BORE SIZE		DISC WIDTH		PART NUMBER
1.38"	35,1 mm	.79" - .86"	20,1 - 21,8 mm	120-8729
1.38"	35,1 mm	.35" - .50"	8,9 - 12,7 mm	120-8726
1.25"	31,8 mm	.79" - .86"	20,1 - 21,8 mm	120-8728
1.25"	31,8 mm	.35" - .50"	8,9 - 12,7 mm	120-8725
1.00"	25,4 mm	.79" - .86"	20,1 - 21,8 mm	120-8727
1.00"	25,4 mm	.35" - .50"	8,9 - 12,7 mm	120-8724

POWERLITE CALIPER, MOUNTING DIMENSIONS:

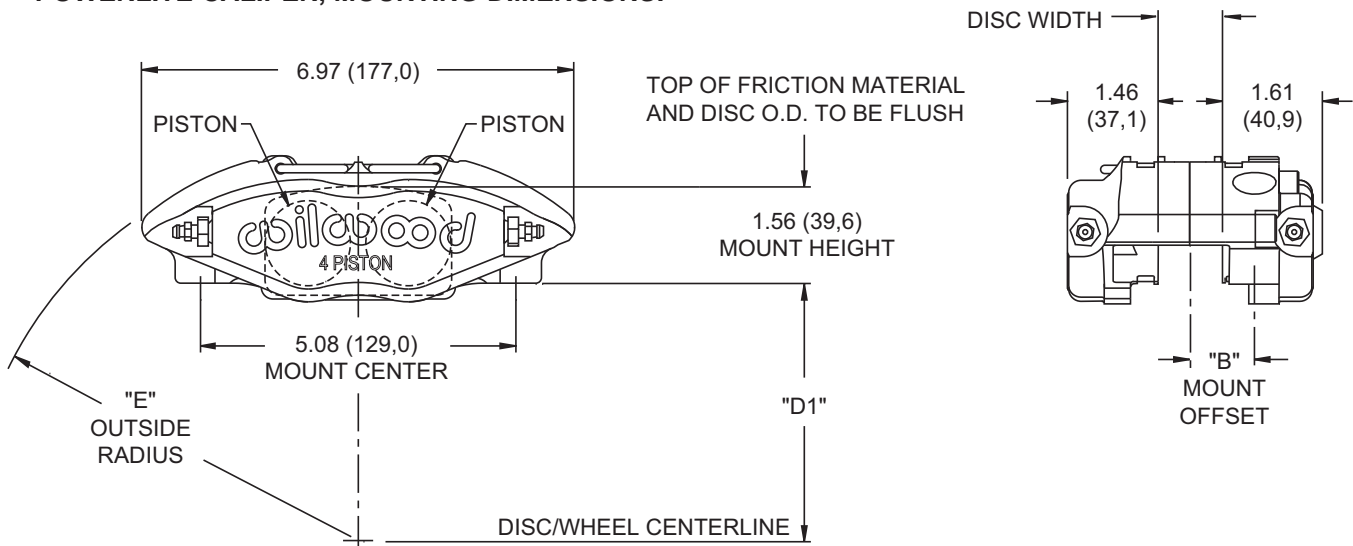

DIMENSION "D1" =
(DISC DIAMETER/2) - 1.56 (39,6)

INLET FITTING: 1/8-27 NPT

DISC WIDTH	"B" MOUNT OFFSET	DISC DIAMETER	"E" OUTSIDE RADIUS	"D1" DIMENSION
.35/.50 (8,9/12,7)	.85 (21,5)	9.75 (247,7)	5.59 (142,0)	3.32 (84,3)
.79/.85 (20,0/22,0)	1.03 (26,2)	10.25 (260,4)	5.81 (147,5)	3.57 (90,7)
		10.50 (266,7)	5.93 (150,5)	3.69 (93,7)
		10.75 (273,0)	6.04 (153,5)	3.82 (97,0)
		11.00 (279,4)	6.16 (156,5)	3.94 (100,1)

POWERLITE CALIPER, TYPE 7912 PAD DIMENSIONS AND ORDERING INFORMATION:

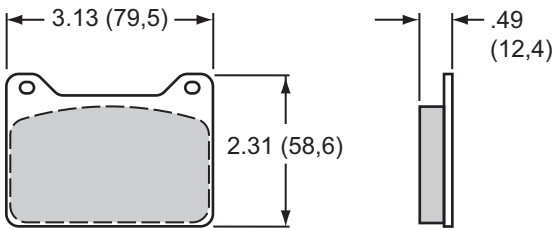

AXLE SET PART NO.	PAD TYPE/COMPOUND
15A - 8809K	7912 A PolyMatrix
15B - 8949K	7912 B PolyMatrix
15E - 8810K	7912 E PolyMatrix
15H - 8811K	7912 H PolyMatrix
15Q - 8812K	7912 Q PolyMatrix
150 - 8813K	7912 10 BP-10 Smart Pad
150 - 9420K	7912 20 BP-20 Smart Pad

ORDERING INFORMATION, USER SERVICEABLE COMPONENTS:

CALIPER PART NO.	PISTON	SQ RING (4 PK)	BLEED SCREW KIT (4 PK)	BODY SEAL (EA)	BRIDGE WEAR PLATE (EA)	PAD RETAINER CLIP PIN (EA)
120-8724	200-8731 (1.00")	130-4320	220-6069	210-2582	300-5875	300-8697
120-8725	200-8730 (1.25")	130-2479	220-6069	210-2582	300-5875	300-8697
120-8726	200-8732 (1.38")	130-2658	220-6069	210-2582	300-5875	300-8697
120-8727	200-8731 (1.00")	130-4320	220-6069	210-2582	300-5875	300-8697
120-8728	200-8730 (1.25")	130-2479	220-6069	210-2582	300-5875	300-8697
120-8729	200-8732 (1.38")	130-2658	220-6069	210-2582	300-5875	300-8697