

## **Front DPHA 4 Piston Caliper Upgrade Kits for Honda/Acura with 262mm Rotors**

### **Models Covered:**

Honda and Acura models originally equipped with 262mm diameter rotors.

### **Kit Highlights:**

- Easy direct bolt-on Forged Billet Aluminum DynaPro Honda/Acura (DPHA) four piston Caliper.
- Calipers bolt directly to the stock mounts on factory spindles originally equipped with the 262 mm diameter rotor.
- Calipers accept the M10 x 1.5 OE brake hose, and are fully compatible with ABS and OE master cylinder output.
- Fits inside many factory aluminum wheels including the EM1 Si 15" wheel.\*

### **Component Features:**

#### **Forged Billet DPHA Calipers**

- Competition proven forged billet aluminum bodies demonstrate superior strength and resistance to deflection and separation under high load.
- Four stainless steel pistons generate high clamping force and balanced pad loading with low heat transfer and high resistance to corrosion. Stainless steel pistons resist corrosion while slowing the heat transfer rate from the pads to the caliper body.
- The internal piston seal-in-bore design adds proven durability with keeping the fluid in and dirt out without the need for external boot seals.
- Spring loaded stainless steel SRS bridge plates reduce noise by dampening engagement harmonics and eliminating pad rattle. SRS plates also extend caliper service life by eliminating bridge gouging at the pad trailing edge.
- Top loaded pads are easily inspected and serviced without the need to remove the caliper from the mount.
- Calipers are available with either black or red gloss powder coat.

#### **ULHP or SRP Series 262mm (10.32") x 21mm (.83") OE Replacement Rotors**

- ULHP plain-face rotors are cast from premium grade, long grain carbon iron, and provide high performance and rugged durability for a wide range of competition, performance, and sport driving applications.
- SRP performance rotors add Wilwood's signature directional drill and slot design with a protective black e-coat finish. The drill and slot pattern adds hi-tech styling with the venting qualities that preserve pad performance. The heat resistant e-coat finish protects the rotors from rust on all areas that are not swept clean by the brake pads.

#### **Wilwood BP-10 "Smart Pads"**

- Wilwood BP-10 Smart Pad is a unique metallic composite formula that provides quiet engagement and low dusting, but with the added temperature range and higher friction values of a semi-metallic compound pad. BP-10 runs clean and quiet on the street, with improved stopping power and fade-resistance for those fun days at the track.
- Optional high-temp and race only pad compounds are also available.



**Front Kit Assembly with Red  
Caliper and SRP Rotor**

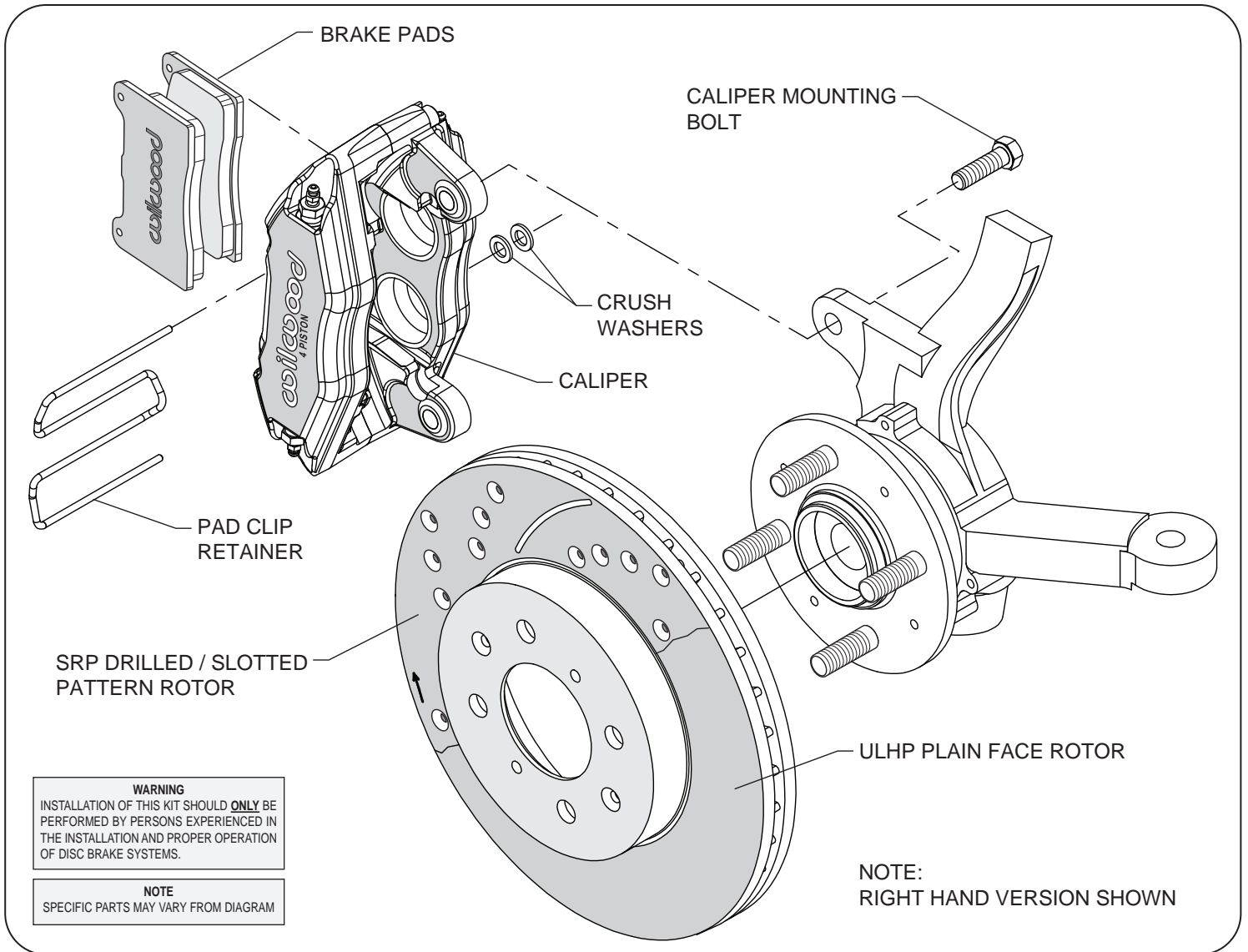

**Typical Installation Diagram, Major Components Identified**

**ORDERING INFORMATION:**

<b><u>PART NUMBER</u></b>	<b><u>DESCRIPTION</u></b>
140-13029	Front Kit, Honda/Acura, DPHA Caliper and Brake Pad Upgrade, Black Caliper
140-13029-R	Front Kit, Honda/Acura, DPHA Caliper and Brake Pad Upgrade, Red Caliper
140-12996	Front Kit, Honda/Acura, DPHA Caliper, Brake Pads, 262mm ULHP Rotor, Black Caliper
140-12996-D	Front Kit, Honda/Acura, DPHA Caliper, Brake Pads, 262mm SRP Drilled and Slotted Rotor, Black Caliper
140-12996-DR	Front Kit, Honda/Acura, DPHA Caliper, Brake Pads, 262mm SRP Drilled and Slotted Rotor, Red Caliper
140-12996-R	Front Kit, Honda/Acura, DPHA Caliper, Brake Pads, 262mm ULHP Rotor, Red Caliper