



FORGED NARROW SUPERLITE RADIAL MOUNT 6R/4R CALIPERS

Caliper Highlights:

The machined billet narrow body Superlite calipers have been prominent for many years throughout the Wilwood Brake Kit product line, and very well known in the motorsports aftermarket. Wilwood's continual development in applied stress flow forging technology brings a new level of design, strength, and durability to this very popular caliper group. The forged **FNSL6R** six-piston and **FNSL4R** four-piston calipers are now the strongest, most durable styled performance radial mount models ever offered in this popular intermediate size caliper group.



The application of stress flow forging technology adds integral strength by realigning the grain structure of the billet alloy within the flow and contour of the body. Simply stated, this process produces the strongest and most efficient aluminum caliper bodies that can be built.

In addition to the structural improvements from the forging process, the **FNSL6R** and **4R** calipers have also taken on the style and robust appearance of their bigger brothers in the W6AR and W4AR caliper groups. All mounting dimensions and the 7416 type pad applications remain the same as the previous BNSL series calipers, so making upgrades is a simple bolt-on.

The popular **FNSL6R** and **4R** caliper models used in most big brake upgrade kits feature Wilwood's signature logo and standard black or red gloss powder coat. Custom powder coat colors, and Wilwood's new custom Quick-Silver nickel plate finish, are also available on a custom order basis.

ORDERING INFORMATION:

| | <u>BORE SIZE</u> | <u>DISC WIDTH</u> | <u>MOUNT</u> | <u>PART NUMBER</u> |
|-----------------|------------------|----------------------|---------------|--|
| 6 Piston | | | | |
| | 1.62/1.12/1.12" | 41, 1/28, 4/28, 4 mm | 1.25" 31,8 mm | Right Hand 120-11778-BK ⁽¹⁾ |
| | 1.62/1.12/1.12" | 41, 1/28, 4/28, 4 mm | 1.25" 31,8 mm | Left Hand 120-11779-BK ⁽¹⁾ |
| | 1.62/1.12/1.12" | 41, 1/28, 4/28, 4 mm | 1.10" 27,9 mm | Right Hand 120-11780-BK ⁽¹⁾ |
| | 1.62/1.12/1.12" | 41, 1/28, 4/28, 4 mm | 1.10" 27,9 mm | Left Hand 120-11781-BK ⁽¹⁾ |
| | 1.38/1.12/1.12" | 35, 1/28, 4/28, 4 mm | 1.10" 27,9 mm | Right Hand 120-12002-BK ⁽¹⁾ |
| | 1.38/1.12/1.12" | 35, 1/28, 4/28, 4 mm | 1.10" 27,9 mm | Left Hand 120-12003-BK ⁽¹⁾ |
| 4 Piston | | | | |
| | 1.75/1.75" | 44, 5/44/5 mm | 1.10" 27,9 mm | R/L 120-11784-BK ⁽¹⁾ |
| | 1.25/1.25" | 31, 8/31, 8 mm | 1.10" 27,9 mm | R/L 120-11783-BK ⁽¹⁾ |
| | 1.12/1.12" | 28, 4/28, 4 mm | 1.10" 27,9 mm | R/L 120-11782-BK ⁽¹⁾ |
| | 1.12/1.12" | 28, 4/28, 4 mm | 0.81" 20,6 mm | R/L 120-11876-BK ⁽¹⁾ |

Note: (1) Calipers come standard in black, for red remove -BK and replace with -RD at end of part number

FNSL6R/4R CALIPER, MOUNTING DIMENSIONS:

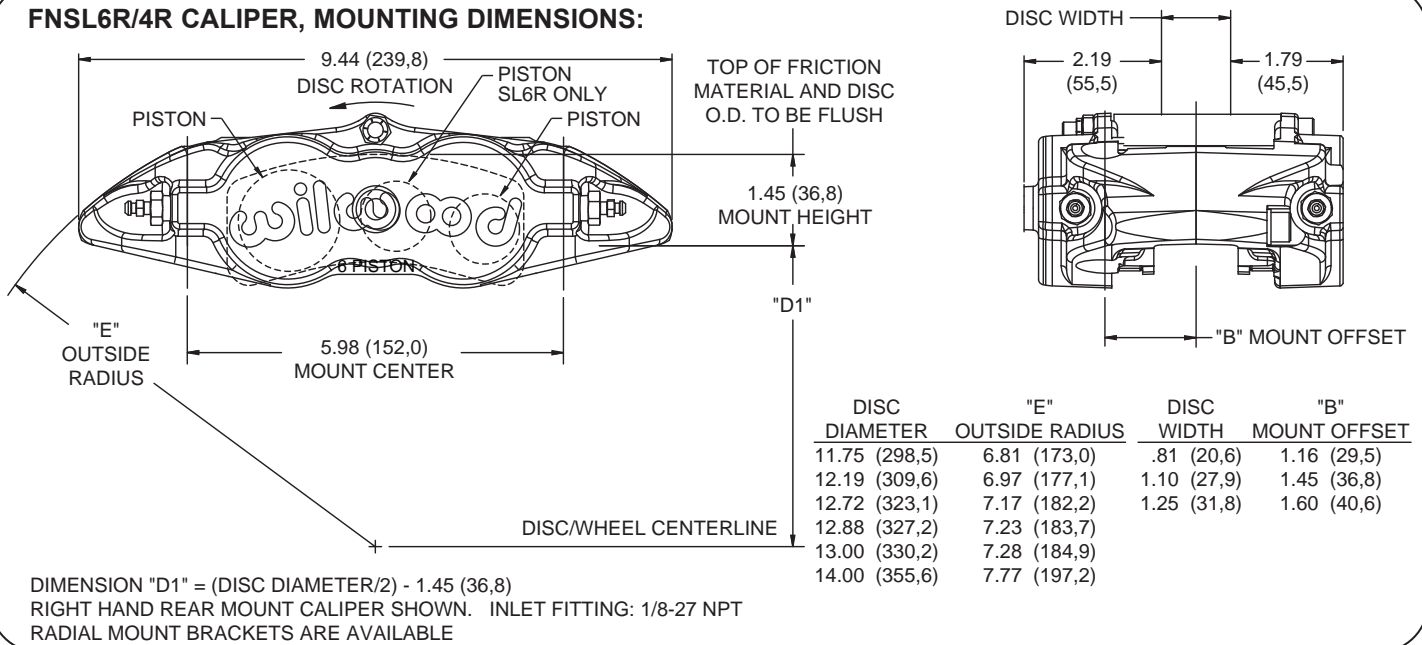

FNSL6R/4R CALIPER, TYPE 7416 PAD DIMENSIONS AND ORDERING INFORMATION:

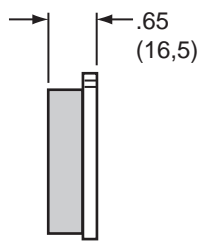
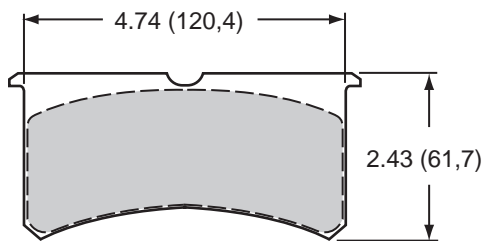

AXLE SET PART NO.

PAD TYPE / COMPOUND

| | | |
|-------------|---------|-----------------|
| 15A - 6704K | 7416 A | PolyMatrix A |
| 15B - 6705K | 7416 B | PolyMatrix B |
| 15E - 6707K | 7416 E | PolyMatrix E |
| 15H - 8546K | 7416 H | PolyMatrix H |
| 15Q - 6828K | 7416 Q | PolyMatrix Q |
| 150 - 8855K | 7416 10 | BP-10 Smart Pad |
| 150 - 9415K | 7416 20 | BP-20 Smart Pad |

FNSL6R ORDERING INFORMATION, USER SERVICEABLE COMPONENTS:

| CALIPER PART NO. | PISTON | SQ RING KIT (6 PK) | BLEED SCREW KIT (4 PK) | BRIDGE BOLT KIT | BRIDGE WEAR PLATE (EA) |
|------------------|--------------------------------------|--------------------|------------------------|-----------------|----------------------------------|
| 120-11778 | 200-7520 (1.62") 200-8439 (1.12") | 130-5972 | 220-0063 | 230-7049 | 300-6595 (L/H) 300-6596 (R/H) |
| 120-11779 | 200-7520 (1.62") 200-8439 (1.12") | 130-5972 | 220-0063 | 230-7049 | 300-6595 (L/H) 300-6596 (R/H) |
| 120-11780 | 200-7520 (1.62") 200-8439 (1.12") | 130-5972 | 220-0063 | 230-7710 | 300-6595 (L/H) 300-6596 (R/H) |
| 120-11781 | 200-7520 (1.62") 200-8439 (1.12") | 130-5972 | 220-0063 | 230-7710 | 300-6595 (L/H) 300-6596 (R/H) |
| 120-12002 | 200-7518 (1.38") 200-8439 (1.12") | 130-12488 | 220-0063 | 230-7710 | 300-6595 (L/H) 300-6596 (R/H) |
| 120-12003 | 200-7518 (1.38") 200-8439 (1.12") | 130-12488 | 220-0063 | 230-7710 | 300-6595 (L/H) 300-6596 (R/H) |

FNSL4R ORDERING INFORMATION, USER SERVICEABLE COMPONENTS:

| CALIPER PART NO. | PISTON | SQ RING KIT (4 PK) | BLEED SCREW KIT (4 PK) | BRIDGE BOLT KIT | BRIDGE WEAR PLATE (EA) |
|------------------|------------------|--------------------|------------------------|-----------------|----------------------------------|
| 120-11782 | 200-8439 (1.12") | 130-2579 | 220-0063 | 230-7710 | 300-6595 (L/H) 300-6596 (R/H) |
| 120-11783 | 200-7515 (1.25") | 130-2479 | 220-0063 | 230-7710 | 300-6595 (L/H) 300-6596 (R/H) |
| 120-11784 | 200-7528 (1.75") | 130-2655 | 220-0063 | 230-7710 | 300-6595 (L/H) 300-6596 (R/H) |
| 120-11876 | 200-8439 (1.12") | 130-2579 | 220-0063 | 230-12489 | 300-6595 (L/H) 300-6596 (R/H) |