

FORGED BILLET D154 GM METRIC OE MOUNT REPLACEMENT CALIPER

Caliper Highlights:

The **D154** GM Metric forged billet caliper is a direct bolt-on, lightweight, high-strength, extreme duty alternative to the OE cast iron calipers that were used on a wide range of factory disc brake equipped mid size GM cars and small trucks beginning in 1978. Use of this caliper can still be found on some GM models as late as the year 2002. The wide spread and affordable availability of **D154** GM Metric calipers and brake pad compounds also made it a popular choice in a number of restricted class competition categories and drum to disc conversions on all types of hot rods and street machines.



Black Powder
 Red Powder
 Polished

The **D154** GM Metric replacement caliper was designed using computer generated 3D modeling and FEA stress analysis technology have been configured to mount in the stock location with included OE type slide-pins to position over the original rotor using standard OE type [brake pads](#). This caliper design features a stress-flow forged billet aluminum body that provides a substantial weight savings over the original cast iron caliper, without any of the rust and corrosion issues that are common to cast iron parts. Stress flow forging realigns the internal grain structure of the metal within the contour of the caliper body to create a caliper that is superior in strength to any cast or machined from block billet caliper design. There simply is no better way to build an aluminum caliper with more strength or less weight.

There are three piston configurations available; the large 2.50" single piston, and two, two-piston models featuring 1.62/1.62" or 1.12/1.12" pistons. All three calipers utilize stainless steel pistons. Stainless pistons are used to resist corrosion and retard heat transfer from the pads into the caliper body. High temperature, square faced bore seals are used to provide controlled piston retraction and reliable performance from the wider sealing face. This combination of components is a proven performer with long service life and a history of reliable performance in any type of driving environment, including extreme sustained high temperature racing applications. The caliper slide pin holes are fitted with dampening rings to minimize noise from vibration. The caliper is also fitted with bleed screws on both ends to facilitate mounting in any left hand or right hand, front leading mount, or rear trailing mount locations.

The caliper inlet port is threaded for use with a M10 x 1.5 banjo bolt or a line adapter using crush washers as a seal. The OE rubber lines can be used from any vehicle equipped with a M10 x 1.5 banjo.

To complete the package, **D154** calipers are available as a regular stock item with brake fluid resistant, high-temp glossy red or black powder coat, or available polished for those wishing to add a different customized look inside the wheels.

ORDERING INFORMATION:

BORE SIZE		DISC WIDTH		BLACK PART NUMBER	RED PART NUMBER	POLISHED PART NUMBER
2.50"	63,5 mm	1.04"	26,4 mm	120-11870-BK	120-11870-RD	120-11870-P
2.50"	63,5 mm	.81"	20,6 mm	120-11871-BK	120-11871-RD	—
1.62/1.62"	41,1 mm	1.04"	26,4 mm	120-11872-BK	120-11872-RD	—
1.62/1.62"	41,1 mm	.81"	20,6 mm	120-11873-BK	120-11873-RD	—
1.12/1.12"	28,4 mm	1.04"	26,4 mm	120-11874-BK	120-11874-RD	120-11874-P
1.12/1.12"	28,4 mm	.81"	20,6 mm	120-11875-BK	120-11875-RD	120-11875-P

D154 CALIPER, MOUNTING DIMENSIONS:

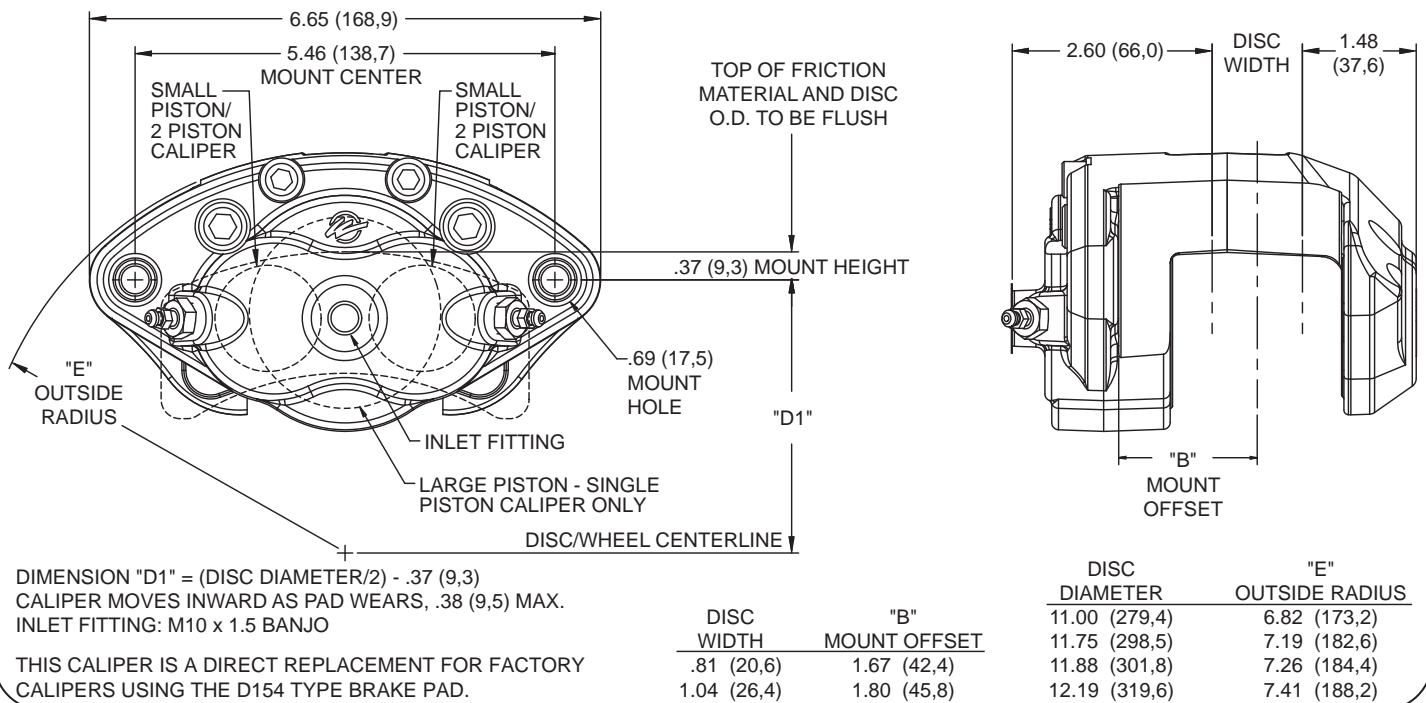

D154 CALIPER, TYPE D154 PAD DIMENSIONS AND ORDERING INFORMATION:

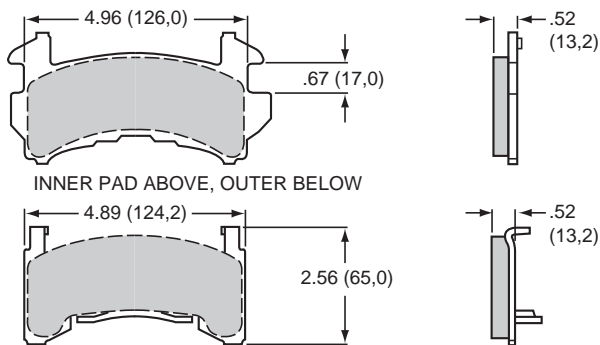

AXLE SET P/N

15A - 6219K
15B - 3998K
15C - 4420K
15E - 6103K
15Q - 6831K
150 - 8936K
150 - 9422K

PAD TYPE / COMPOUND

D154 A PolyMatrix
D154 B PolyMatrix
D154 C PolyMatrix
D154 E PolyMatrix
D154 Q PolyMatrix
D154 10 BP-10 Smart Pad
D154 20 BP-20 Smart Pad

ORDERING INFORMATION, USER SERVICEABLE COMPONENTS:

CALIPER PART NO.	PISTON	O-RING KIT (4 PK)	BLEED SCREW KIT (4 PK)	SLIDE PIN KIT (4 PK)
120-11870	200-11793	130-12084	220-0627	230-11529
120-11871	200-11793	130-12084	220-0627	230-11529
120-11872	200-11794	130-4346	220-0627	230-11529
120-11873	200-11794	130-4346	220-0627	230-11529
120-11874	200-11795	130-2579	220-0627	230-11529
120-11875	200-11795	130-2579	220-0627	230-11529