



PT Series Manual Trolley – Installation and Safety Instructions

JET Manual Trolleys are designed to be used on either "I" or "H" wide flange beams.

JET PT Series Trolleys comply with OSHA regulations, ANSI/ASME B30.11 and B30.17 standards.



IMPORTANT SAFETY INSTRUCTIONS

To reduce risk of injury:

1. Beam must be properly installed and rated for anticipated loads.
2. Do not install trolley on beams of unknown capacity.
3. Do not install trolley on damaged or deformed beams.
4. JET trolleys are designed to be used with hoists of the same rated capacity. Never use a hoist with a capacity greater than the capacity of the trolley.
5. Never subject trolley to a side pull or load. Load must be centered directly under the hoist / trolley assembly.
6. Make sure load is stable and secure before moving.
7. Never lift load more than is necessary to safely move it.
8. Always follow installation instructions.
9. Do not use if under the influence of drugs, alcohol, or medication.

Installation Instructions

(refer to Figure 1)

1. Trolley must be installed on a beam with minimum clearance (wheels to flange) of 1/16" to maximum of 1/8". Reference "Z" on both sides of the beam.
2. To extend trolley width, remove split pins and hex nuts. Remove washers from center bolt and place between hanger plate and fixed spacer. **Note:** Washers **must** be moved in sets of two, one on either side of hanger plate, as hanger plate must always remain centered between trolley side plates.
3. Once trolley width is spaced properly, install remaining washers on center bolt (same number on both sides) on outside of side plates. Install hex nuts and split pins. **Do not over tighten nuts.** Tighten nuts and then back nuts off to align the nut with hole in shaft for split pin. Insert split pin through each hex nut and bend one end of split pin to secure.
4. Re-check wheel clearance "Z" and re-adjust if necessary

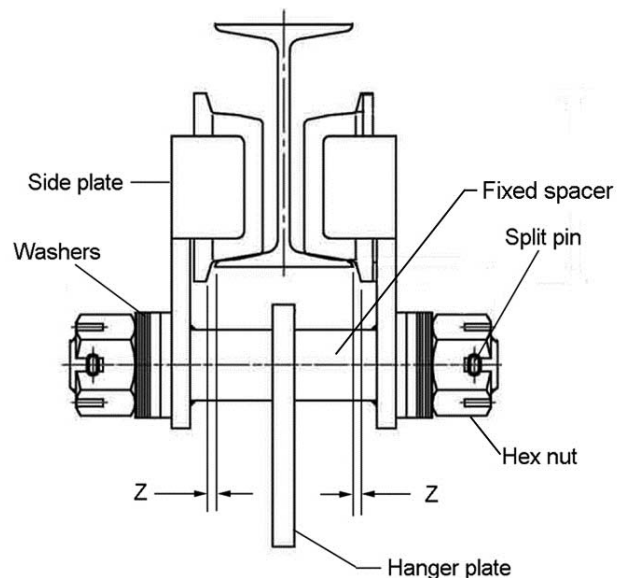
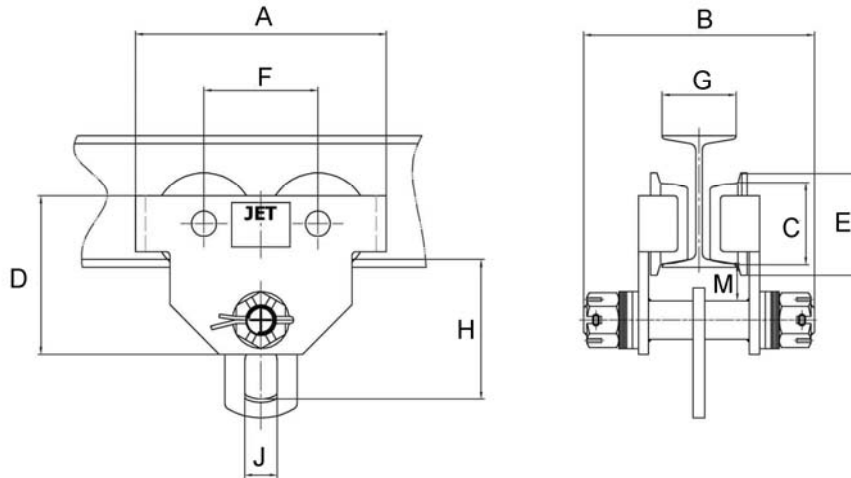

Figure 1

PT Series Trolley: Specifications



Capacity (Ton)	Stock No.		Beam Flange Width G (min-max)	Min. Radius Curve	Shipping Weight	A	B	C (Ø)	D	E (Ø)	F	H	J	M
1/2 Ton	252005	mm	64-203	900	8.5 (kg)	212	312	58	130	82	102	113	24	37.5
		in.	2-1/2-8	35	19 (lb)	8.35	12.28	2.28	5.12	3.23	4	4.45	0.95	1.5
1 Ton	252010	mm	76-203	1000	15 (kg)	252	330	75	155	102	118	128	30.5	32.5
		in.	3-8	39	33 (lb)	9.92	13	2.95	6.10	4	4.65	5.04	1.20	1.28
1-1/2 Ton	252015	mm	82-203	1100	18.5 (kg)	281	336	85	162	115	124	145	33	35.5
		in.	3-1/4-8	43	41 (lb)	11.06	13.23	3.35	6.38	4.53	4.88	5.71	1.3	1.4
2 Ton	252020	mm	82-203	1100	23 (kg)	302	350	90	170	127	137	152	36	35.75
		in.	3-1/4-8	43	51 (lb)	11.89	13.78	3.54	6.69	5	5.40	5.98	1.42	1.41
3 Ton	252030	mm	102-203	1300	37.5 (kg)	346	370	110	217	147	157	186	45	50.75
		in.	4-8	51	83 (lb)	13.62	14.57	4.33	8.54	5.79	6.18	7.32	1.77	2
5 Ton	252050	mm	117-203	1400	54.5 (kg)	382	400	122	255	160	172	219	60	58.75
		in.	4-5/8-8	55	120 (lb)	15.04	15.75	4.80	10.04	6.30	6.77	8.62	2.36	2.3
10 Ton	252060	mm	120-203	1700	92 (kg)	455	432	151	295	189	200	275	82	75.25
		in.	4-3/4-8	67	202 (lb)	17.91	17	5.94	11.61	7.44	7.87	10.83	3.23	3

Specifications in this document were current at time of publication, but because of our policy of continuous improvement, JET reserves the right to change specifications at any time and without prior notice, without incurring obligations.

PT Series Trolley: Parts Breakdown

Index	Part No.	Description	Qty
1	1/2PT-1	Wheel (1/2 ton)	4
	1PT-1	Wheel (1 ton)	4
	1-1/2PT-1	Wheel (1-1/2 ton)	4
	2PT-1	Wheel (2 ton)	4
	3PT-1	Wheel (3 ton)	4
	5PT-1	Wheel (5 ton)	4
	10PT-1	Wheel (10 ton)	4
2	BB-6203ZZ	Bearing (1/2, 1 ton)	4
	BB-6204ZZ	Bearing (1-1/2 ton)	4
	BB-6205ZZ	Bearing (2 ton)	4
	BB-6206ZZ	Bearing (3 ton)	4
	BB-6207ZZ	Bearing (5 ton)	8
	BB-6210ZZ	Bearing (10 ton)	8
3	F006045	Snap Ring ø17mm (1/2, 1 ton)	4
	F006047	Snap Ring ø20mm (1-1/2 ton)	4
	F006050	Snap Ring ø25mm (2 ton)	4
	F006052	Snap Ring ø30mm (3 ton)	4
	F006054	Snap Ring ø35mm (5 ton)	4
4	F006071	Snap Ring ø50mm (10 ton)	4
	1/2PT-4	Shield (1/2, 1 ton)	4
	2HDT-4	Shield (1-1/2 ton)	4
	2PT-4	Shield (2 ton)	4
	3PT-4	Shield (3 ton)	4
	5HDT-4	Shield (5 ton)	4
5	10PT-4	Shield (10 ton)	4
	F006035	Snap Ring ø40mm (1/2, 1 ton)	4
	F006072	Snap Ring ø47mm (1-1/2 ton)	4
	F006073	Snap Ring ø52mm (2 ton)	4
	F006038	Snap Ring ø60mm (3 ton)	4
	PT5-5	Snap Ring ø72mm (5 ton)	4
6	PT10-5	Snap Ring ø90mm (10 ton)	4
	1/2PT-6	Shaft (1/2 ton)	1
	1PT-6	Shaft (1 ton)	1
	1-1/2PT-6	Shaft (1-1/2 ton)	1
	2PT-6	Shaft (2 ton)	1
	3PT-6	Shaft (3 ton)	1
	5PT-6	Shaft (5 ton)	1
7	10PT-6	Shaft (10 ton)	1
	1/2PT-7	Side Plate (1/2 ton)	2
	1PT-7	Side Plate (1 ton)	2
	1-1/2PT-7	Side Plate (1-1/2 ton)	2
	2PT-7	Side Plate (2 ton)	2
	3PT-7	Side Plate (3 ton)	2
	5PT-7	Side Plate (5 ton)	2
	10PT-7	Side Plate (10 ton)	2
8	1/2GBT-23	Split Pin ø4x50mm (1/2 ton)	2
	1GBT-23	Split Pin ø6x65mm (1 ton)	2
	2GBT-23	Split Pin ø6x75mm (2 ton)	2
	3GBT-23	Split Pin ø6x80mm (3 ton)	2
	5GBT-23	Split Pin ø8x80mm (5 ton)	2
	10GBT-23	Split Pin ø8x90mm (10 ton)	2

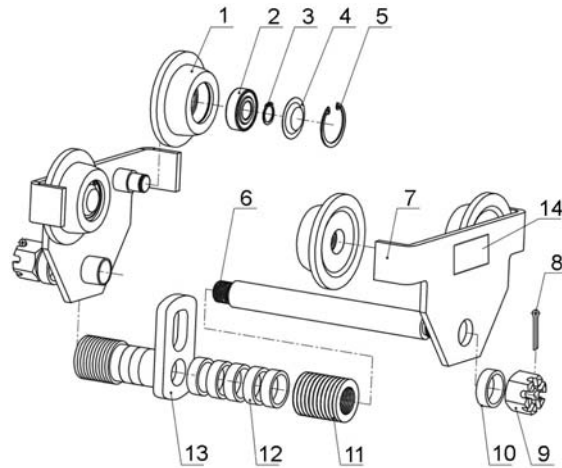

Index	Part No.	Description	Qty
9	1/2GBT-26	Nut M24 (1/2 ton)	2
	1GBT-26	Nut M30 (1, 1-1/2 ton)	2
	2GBT-26	Nut M36 (2 ton)	2
	3GBT-26	Nut M42 (3 ton)	2
	5GBT-26	Nut M42 (5 ton)	2
	10GBT-26	Nut M48 (10 ton)	2
10	5PT-10	Outer Adjusting Washer (5 ton)	2
	10PT-10	Outer Adjusting Washer (10 ton)	2
11	1/2GT-31	Adjusting Washer 8mm (1/2 ton)	18
	1GT-31	Adjusting Washer 8mm (1 ton)	10
	1-1/2PT-11	Adjusting Washer 8mm (1-1/2 ton)	16
	2GT-31	Adjusting Washer 8mm (2 ton)	16
	3GT-31	Adjusting Washer 8mm (3 ton)	16
	5GT-31	Adjusting Washer 8mm (5 ton)	16
12	10GT-31	Adjusting Washer 8mm (10 ton)	16
	1/2GT-32	Adjusting Washer 2mm (1/2 ton)	14
	1GT-32	Adjusting Washer 2mm (1 ton)	14
	1-1/2PT-12	Adjusting Washer 2mm (1-1/2 ton)	12
	2GT-32	Adjusting Washer 2mm (2 ton)	12
	3GT-32	Adjusting Washer 2mm (3 ton)	10
13	5GT-32	Adjusting Washer 2mm (5 ton)	8
	10GT-32	Adjusting Washer 2mm (10 ton)	8
	1/2GBT-29G	Hanger Plate (1/2 ton)	1
	1GBT-29G	Hanger Plate (1 ton)	1
	1-1/2PT-13G	Hanger Plate (1-1/2 ton)	1
	2GBT-29G	Hanger Plate (2 ton)	1
14	3GBT-29G	Hanger Plate (3 ton)	1
	5GBT-29G	Hanger Plate (5 ton)	1
	10GBT-29	Hanger Plate (10 ton)	1
	LM000094	Name Plate 1/2PT	2
	LM000095	Name Plate 1PT	2
	LM000096	Name Plate 1-1/2PT	2
	LM000097	Name Plate 2PT	2
	LM000098	Name Plate 3PT	2
LM000099	Name Plate 5PT	2	
LM000100	Name Plate 10PT	2	

1/2PT-SPK, Spacer Kit for 1/2 ton (includes #11 and 12)
 1-1/2PT-SPK, Spacer Kit for 1 1/2 ton (includes #11 and 12)
 1PT-SPK, Spacer Kit for 1 ton (includes #11 and 12)
 2PT-SPK, Spacer Kit for 2 ton (includes #11 and 12)
 3PT-SPK, Spacer Kit for 3 ton (includes #11 and 12)
 5PT-SPK, Spacer Kit for 5 ton (includes #11 and 12)
 10PT-SPK, Spacer Kit for 10 ton (includes #11 and 12)