

10518	82-92	CHEVROLET	CAMARO / Z28	(W/O 3RD BRAKE LIGHT)
10519	82-92	CHEVROLET	CAMARO / Z28	(W/ WIPER, W/O 3RD BRAKE LIGHT)
10610	86-92	CHEVROLET	CAMARO / Z28	(W/ 3RD BRAKE LIGHT ON GLASS)
10894	86-87	PONTIAC	TRANS AM	(W/ SPOILER, W/ 3RD BRAKE LIGHT)
10985	88-91	PONTIAC	TRANS AM	(W/ SPOILER, W/O 3RD BRAKE LIGHT)

NOTE:

THE **LOUVER** IS NOT READY FOR INSTALLATION ON THE CAR.

You will need the following items on hand to properly install the louver.

- Paper towels or a clean lint free rag to clean the window
- A bottle of rubbing alcohol to clean the window.
NOTHING ELSE WILL CLEAN PROPERLY WITHOUT REDUCING THE STRENGTH OF THE ADHESIVE!!!
- A water soluble felt tip marker or soft lead pencil to mark the location of the attaching hardware.
- A phillips head screw driver

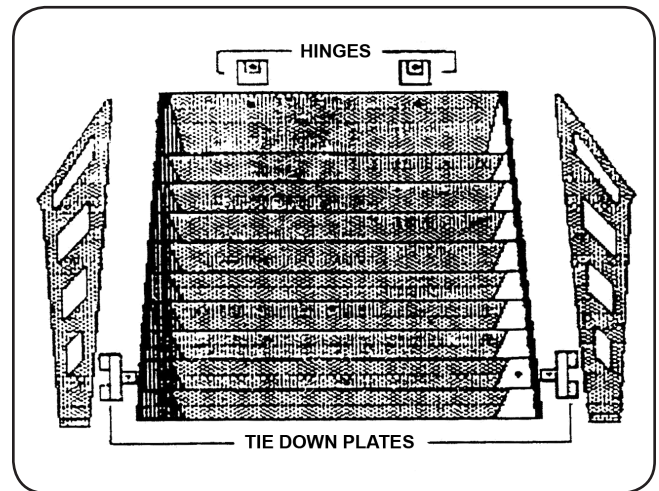

1. READ INSTRUCTIONS COMPLETELY BEFORE STARTING.

Refer to drawings often. Check hardware kit before starting to insure all pieces are included. Make sure you have the right part number. The louver number is stamped on the back of the slats.

CAUTION!!!

Before proceeding, be sure the glass is completely clean and warm. The glass should be washed with warm, mild detergent solution and rinsed with fresh water and thoroughly dried. Then clean with denatured alcohol using a lint free cloth. The glass should feel "warm" to the touch immediately before the louver attaching parts are installed. The necessary temperature can be attained by using a blower type hair dryer or heat gun.

FAILURE TO PROPERLY CLEAN THE GLASS OR WARM THE GLASS CAN RESULT IN FAILURE OF THE ADHESIVE SYSTEMS USED TO HOLD THE LOUVER TO THE CAR.

2. ASSEMBLY STEPS

1. Lay the louver on a flat non-abrasive surface (a carpeted floor, the louver packing material or a piece of cardboard will do). The louver should be on its back with the side of the louver pointing upward.
2. Start on one side of the louver and slip the exposed slat of one half into the channel side piece of the other half and push the halves together.
3. Repeat the process with the opposite side of the louver making sure the center bar tongue and groove assembly slips together. Note: Due to the geometry of some louvers, the lower piece may need to be bowed slightly to allow the two halves to slide together.
4. When the entire louver is in one piece, screw the two halves together at the center bar using the Phillips head screw provided. The center bar has a strip of adhesive padding applied which will need to be peeled back slightly to expose the screw hole.
5. After assembling the louver and tightening the center screw proceed to add the side splints. The splints are $\frac{3}{4}$ " wide and 6" long with an adhesive strip applied on one side. Clean the louver surface as shown. Peel the cover from the adhesive and apply as shown in the diagram.

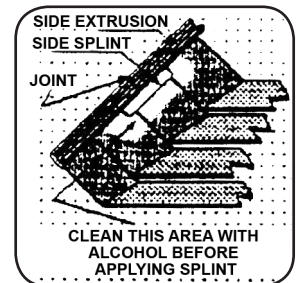

Bonding takes 24 hours to cure. Allow the adhesive to cure fully before proceeding with louver installation.

6. Take the 1/8" inch by 1/2" inch foam, supplied in the attaching parts kit and remove the backing from the adhesive. Center the pad on the brake light at the top of the glass. The top slat of the louver is designed to rest on this pad. (**Part #10610 ONLY**).
7. Take the two side panels and "trial fit" each to the glass. The flange at the rear of each panels is designed to slide under the metal portion of the deck lid. Use a water soluble felt marker or soft pencil to mark the location of the side panel in its best fit location. The panel is designed to line up flush with the edge of the glass and should rest on top of the metal molding that covers the edge of the glass.
8. Remove the vinyl backing from all of the "Dual Lock" mounting pads on the side panel. Do one side at a time. A knife blade may be useful to lift a corner of the vinyl to ease its removal. To install a panel, first slide the flange under the rear deck. Then carefully align the location marks from Step 7 and press the panel firmly in place.
9. Examine all adhesive locations through the glass (where visible) from the back side for complete contact with the glass. Any bubbles should be eliminated by applying additional pressure to the mounting pad area until the bubbles disappear.

10. Repeat Steps 7 and 8 for the remaining side panel.

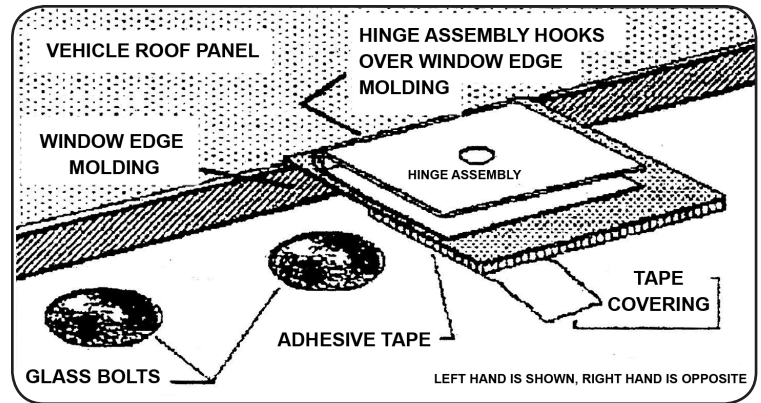
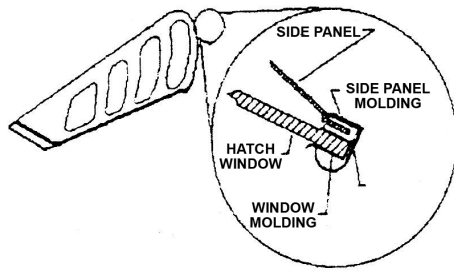

11. Peel back a corner of the adhesive covering on each hinge assembly as shown above. Slide each over the top edge of the glass as shown. Adjust the spacing to match that of the hinge holes in the top slat of the louver.
12. Peel back a corner of the adhesive covering on the tie down plates. Position the tie down plates on the glass in the lower corners sliding the tabs under the side panels as shown below. Make sure the tie down plate conforms to the curvature of the glass. This may be accomplished by simply bending the tabs on the plates as required to achieve a flush fit.

TIE DOWN PLATES THAT HAVE NOT BEEN FORMED TO THE CONTOUR OF THE GLASS MAY RESULT IN ADHESIVE FAILURE!!!!

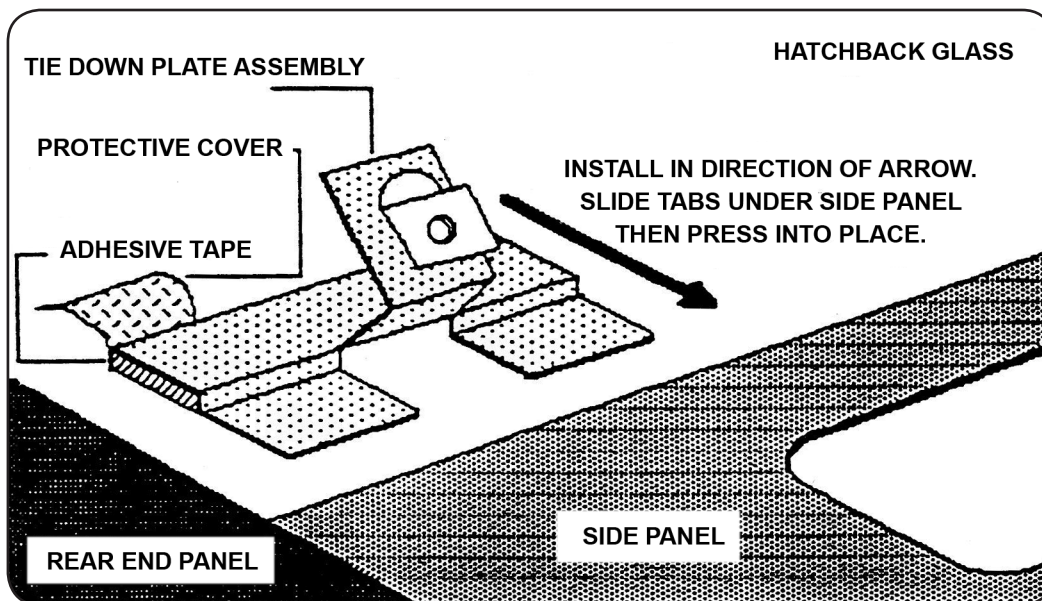

13. Now place the louver on the rear window and side panels. The unit should be centered right to left and top to bottom on the window. Re-adjust the hinges as necessary to line up with the hinge holes in the top slat of the louver. Mark the position of the hinges on the window molding and the carefully install the hinge screws as shown below. The screws should be snug but not tight at this time.

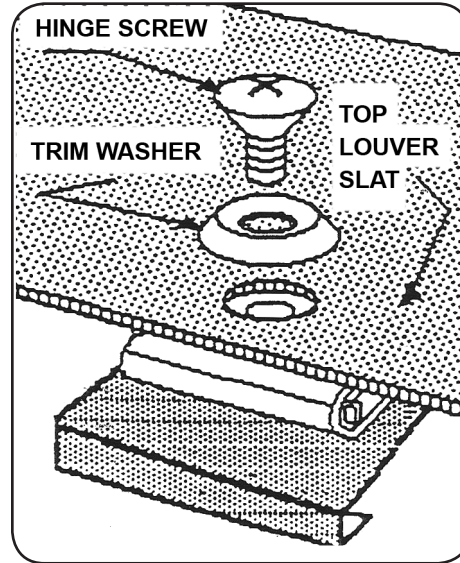

14. Now adjust the position of the tie down plates to line up with the locking studs, which are mounted in the louver. Use a slotted screwdriver to lock the louver to the tie down plate. Turn the key clockwise to lock and counter-clockwise to unlock. Adjust the clip location on the tie down plate tab or the angle of the tab to be sure the lock will perform properly after permanent installation.
15. With the louver loosely attached, open the hatch and carefully swing to its full open position. Check closely for any interference between the louver and the vehicle roof panel. Adjust the position of the louver as necessary.
16. Carefully unlock the tie down plates from the louver without moving the plates. Mark the plate locations.
17. Remove the hinge screws and then remove the louver from the vehicle.
18. Hold the hinges and tie downs carefully in their previously marked locations. Peel the remaining covering from the adhesive strips. Press each hinge and tie down FIRMLY in place.

LOOK THROUGH THE GLASS FROM THE BACK SIDE (WHERE POSSIBLE) TO BE SURE THAT YOU HAVE 100% CONTACT BETWEEN THE ADHESIVE AND THE GLASS.

19. Reinstall the louver. Do not tighten the hinge screws until you have fastened the 1/4" turn studs to the tie down plates. Once the tie downs are fully engaged, reinstall the hinge screws and fully tighten them.

Bonding takes 24 hours to cure.
Do not install the louver during this time period.
Do not wash car or drive in rain during this period.