

Installation Guide

Front Lower Control Arm - Inner - Offset

Suits: Holden Commodore VE 8/06 - on
Pontiac G8 8/06 - on

(Always refer to the current catalogue for complete application listings)

N.B: High Duro Parts may induce NVH in some applications

N.B: These instructions should be used in conjunction with the workshop manual.

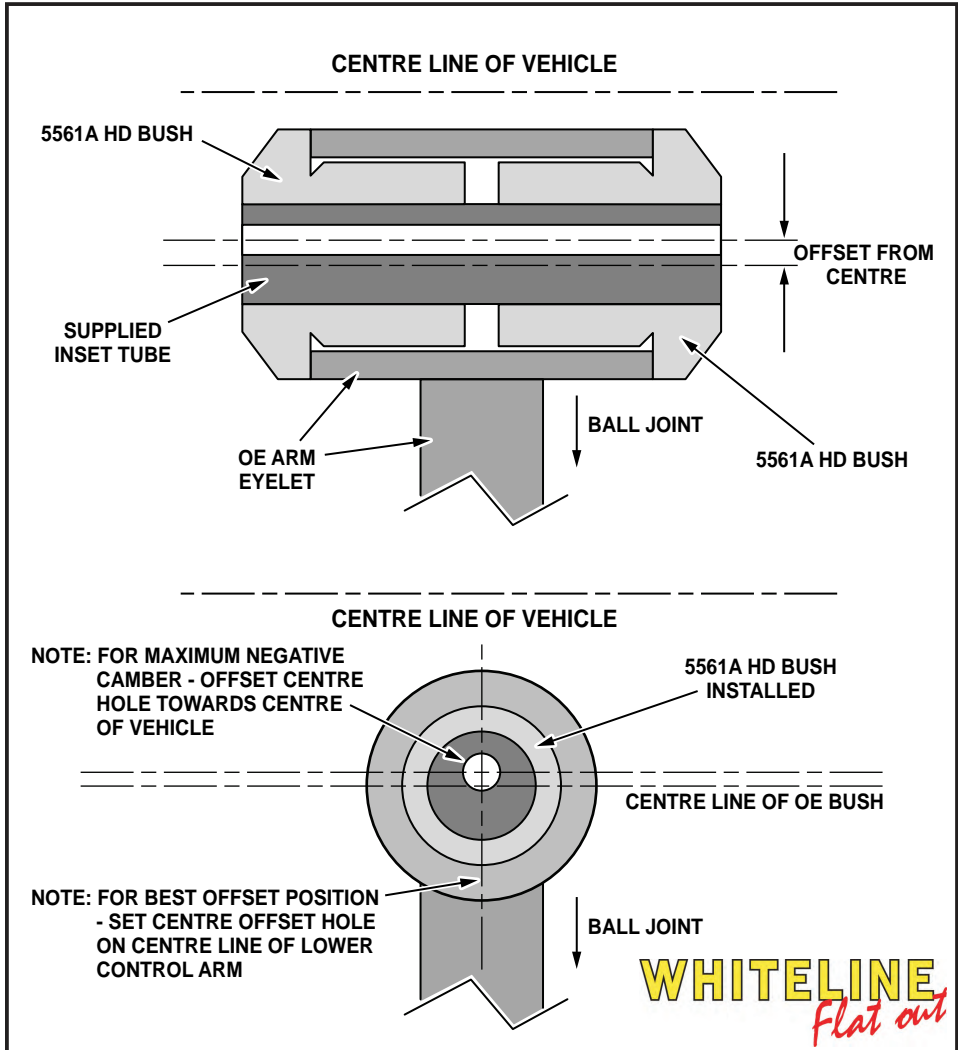

N.B: It is recommended that a licenced workshop or trades person carry out the above procedure and that workshop manual and relevant safety procedures are followed in addition to the above.