

Installation Guide

ADJUSTABLE SWAYBAR LINKS

(Always refer to the current catalogue for complete application listings)

N.B: This installation guide should be used in conjunction with the workshop manual. FIGURE 1

1. Drive the vehicle up on ramps (if available) or alternatively raise the vehicle evenly on both sides and support with jack stands.
 2. Loosen and remove the existing OE sway bar links.
 3. Use a ruler or tape measure to check and confirm your OE link length.
 4. Please remember to leave at least 10mm of ball link thread in the lock nut, you can check this by completely removing the ball link and marking the thread. (REFER FIG 1)
 5. Once the length is determined, hand tighten all lock nuts with fingers. (REFER FIG 3)
- Note : Studs can point in any direction to suit application.
6. Place the supplied washers over each stud prior to installation. After installing one side check that the other link's studs line up with the sway bar and control arm holes. If you find the studs won't easily slide in then you now have the ability to fine tune the length of the adjustable ball link to remove any unwanted sway bar pre load.
 7. Once both links are installed and there are no visible clearance issues, then tighten all lock nuts with appropriate spanners.
 8. Check all fittings after test drive and recheck after initial 100km.

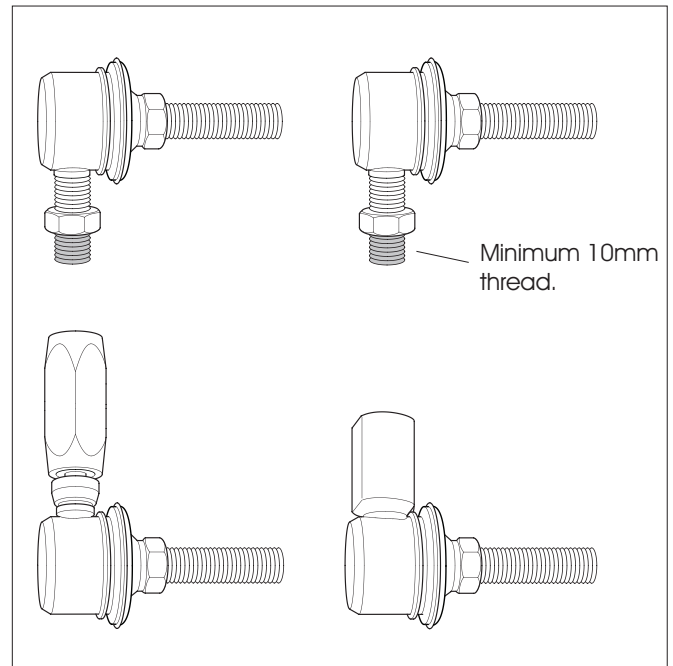

FIGURE 2

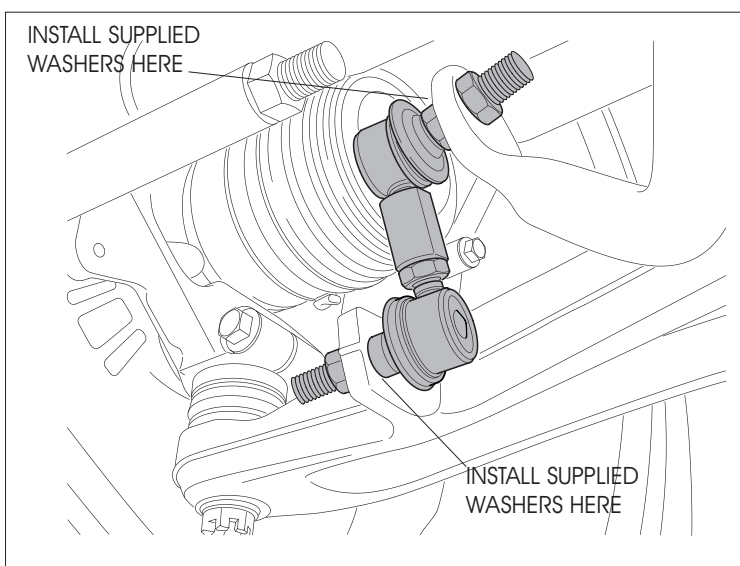
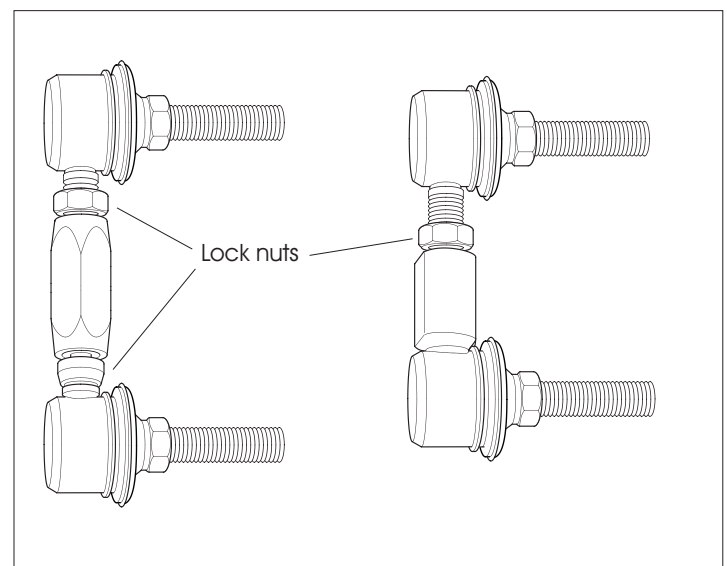

FIGURE 3



Warning: Please drive carefully after fitting any suspension modifications while you accustom yourself to the vehicles changed behaviour.

Note: It is recommended that a licensed workshop or trades person carry out the above procedure and that the workshop manual be used in conjunction with the above.