

Installation Guide

Front Lower Control Arm Rear alloy bush

Suits: Mitsubishi Lancer EVO10

(Always refer to the current catalogue for complete application listings)

N.B: This installation guide should be used in conjunction with the workshop manual.

Right hand top side of arm shown

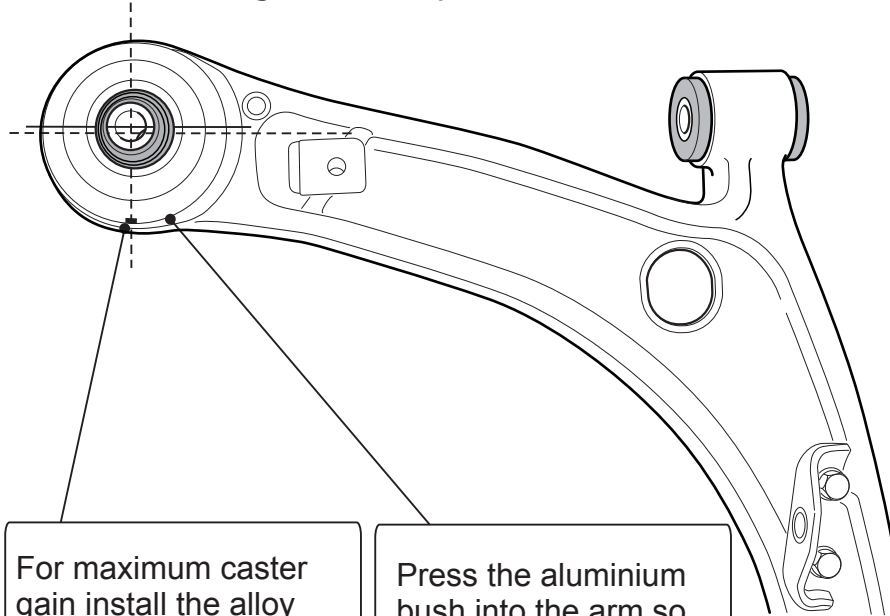

For maximum caster gain install the alloy bush into the arm with the installation indicator notch pointing outward.

Press the aluminium bush into the arm so the large aluminium flange face is installed facing up.

Remove the arm from the vehicle and press the oe bush out of the arm.

Ensure the aluminium arm is free of burrs and install the zero compliance alloy bush into the arm.

N.B: It is recommended that a licenced workshop or trades person carry out the above procedure and that workshop manual and relevant safety procedures are followed in addition to the above.

Note:

Zero compliance alloy mounting joints allow for minimal toe change and dynamic anti geometry change during braking and acceleration enabling a more consistent alignment angle and feel to be maintained.

Underside of arm shown

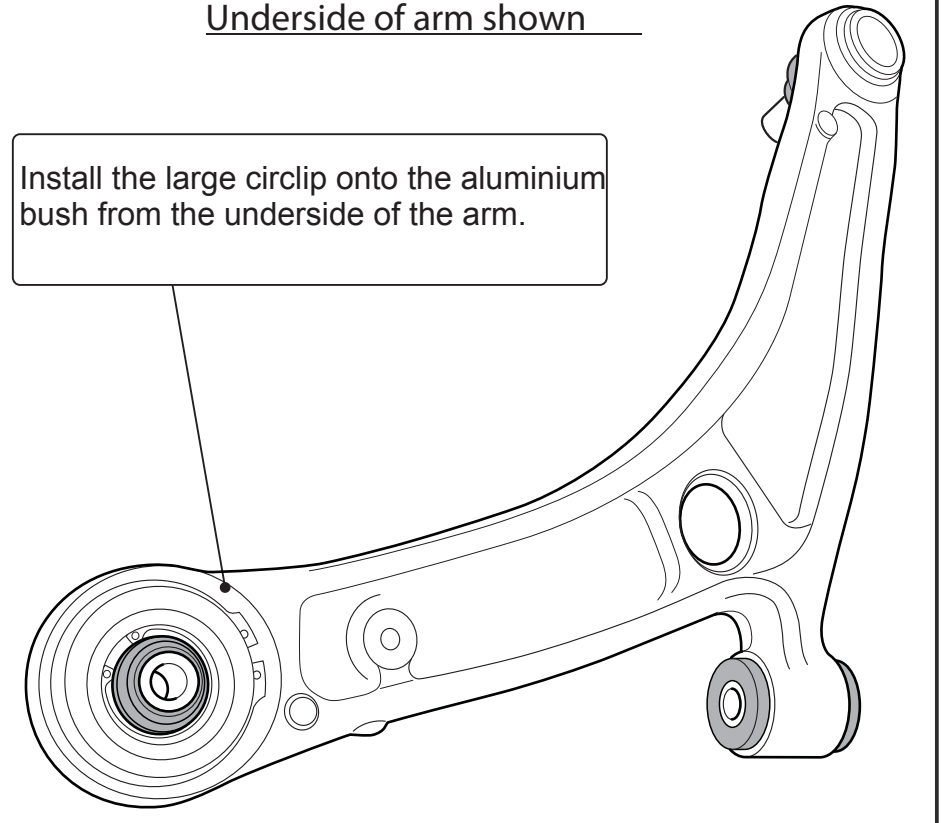

Install the large circlip onto the aluminium bush from the underside of the arm.

WHITELINE
Flat out