

KCA316 - Anti - Lift Kit Side 1

Suits: VW Golf Mk 5 FWD and AWD
VW Passat Mk 6

(Always refer to the current catalogue for complete application listings)

N.B: This installation guide should be used in conjunction with the workshop manual

1. Raise the vehicle on a hoist or alternatively jack the front of the vehicle and place on safety stands.
 2. Disconnect the lower ball joint from the hub.
 3. Remove the front lower control arm front retaining bolt.
 4. Remove the front lower control arm rear vertical mount bolts (x 3 on each side).
 5. Using a suitable press and press tools, remove the old bush and housing from the control arm rear mounting point. Discard.
 6. Remove all rubber deposits, paint and rust from the arm hex spigot. Repair or replace as necessary.
 7. Remove the small centre bush 60316A from the extrusion assembly (refer Fig.1) and press onto the hex spigot using a small amount of the grease supplied.
 8. Grease the outside of the fitted hex spigot bush 60316A and the inside of the pre-assembled extrusion bush 60316B. Press the arm with 60316A fitted into the extrusion containing 60316B.
- Note: Failure to release the excess air will make the arm more difficult to re-install as the mounting holes will not easily align. (refer FIG 1 + FIG2).**
9. Refit the front lower control arm to the vehicle, install the front mount bolt but do not tension at this time.
 10. Before installing the ball joint fit the rear mount vertical bolts.
- Note: It may be necessary to loosen and/or re-align the subframe at this time. This can be done by loosening the 6 remaining subframe mount bolts (refer Fig.4) and fitting all removed components.**
11. Refit the lower ball joint and tension to manufacturers specifications.
 12. Tension all removed and loosened hardware at this stage with the vehicle at ride height.
 13. It is necessary to complete a four-wheel alignment at this stage.
 14. Check and retension all fittings after 100km but not more than 200km.

KIT PARTS

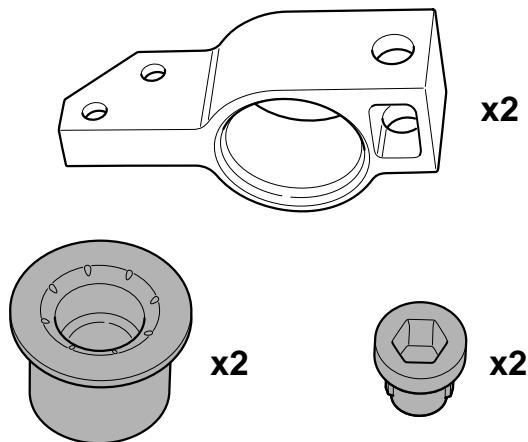

FIG.1

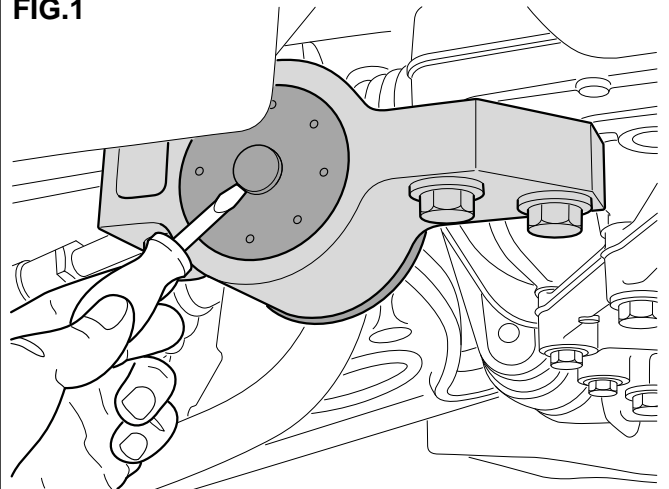

FIG.2

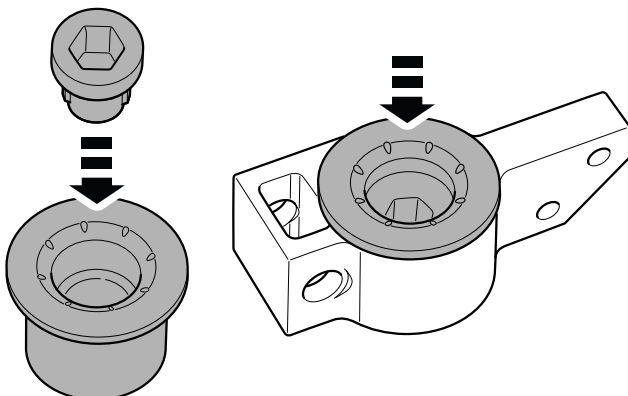
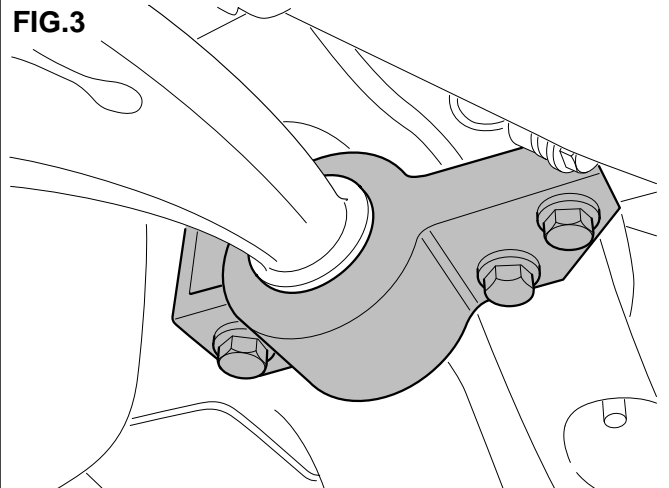

FIG.3



Installation Guide

KCA316 - Anti - Lift Kit Side 2

Suits: VW Golf Mk 5 FWD and AWD VW Passat Mk 6

(Always refer to the current catalogue for complete application listings)

N.B: This installation guide should be used in conjunction with the workshop manual

FIG.4

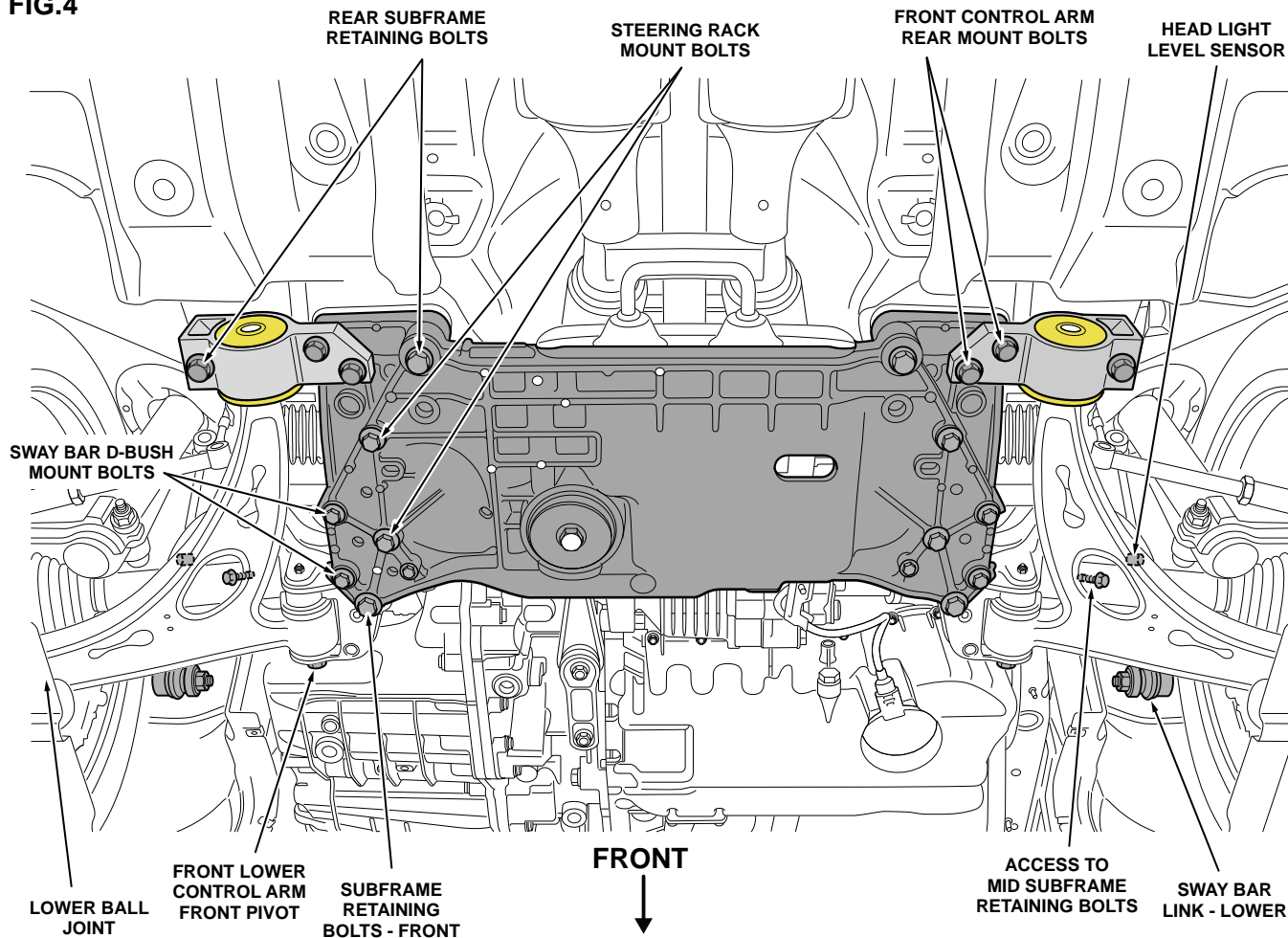

Install Guide - Motorsport Use

Z5372

KCA316 - Anti - Lift Kit

- This Anti-lift kit is supplied with 2 extra bushing inserts in RED.
- For motorsport activities only, we recommend utilizing the RED bushing inserts.

*** Please note the extra RED MOTORSPORT bushings are not TUV approved. Please use the black bushings for TUV or street use ***

- Please see figure below.

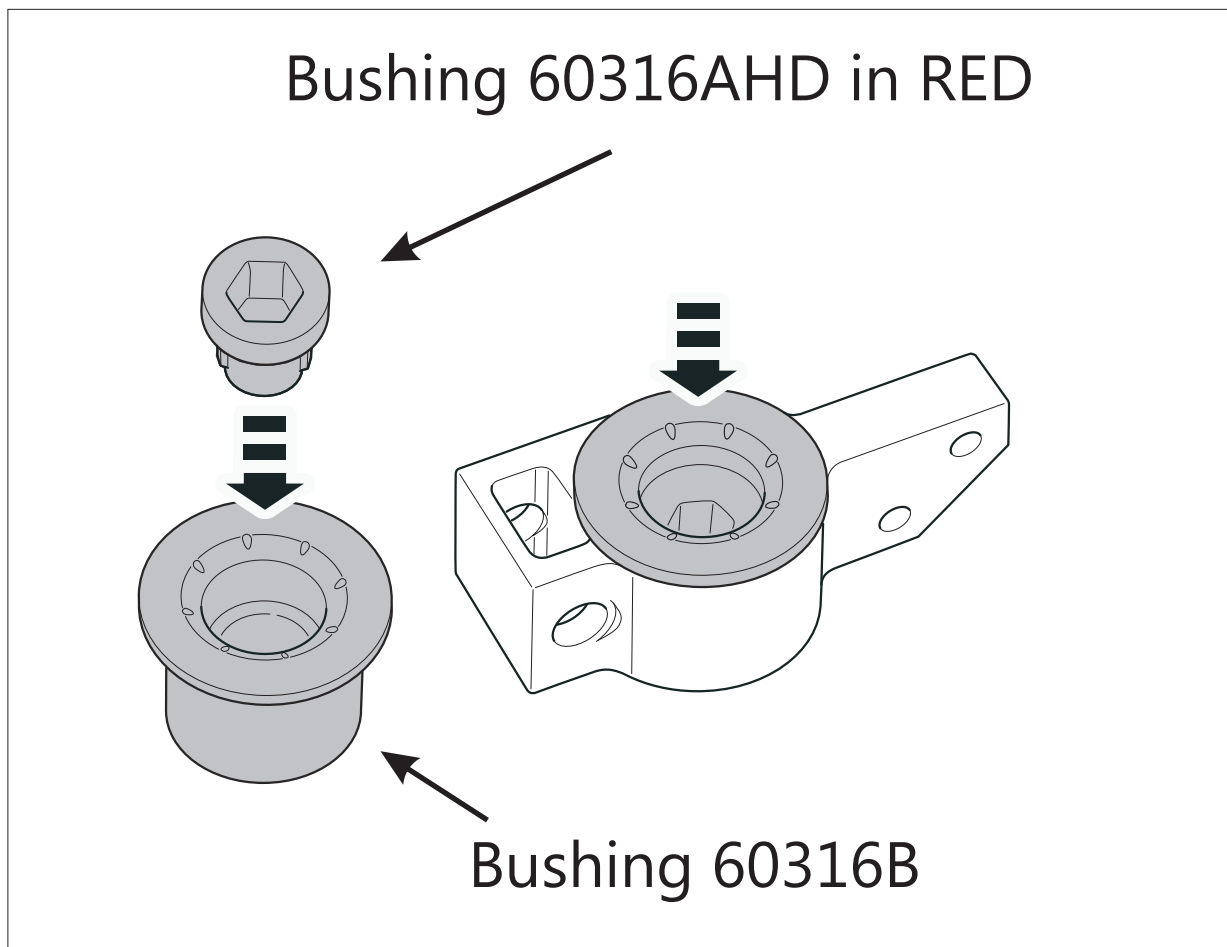

N.B: This installation guide should be used in conjunction with the workshop manual