

(Always refer to the current catalogue for complete application listings)

Alloy high performance lateral locks are designed to maintain Swaybar centralization.

1. Once you have your Swaybar in position and central with links attached, attach the lateral locks next to the mounting bush (leave approx 3-4mm gap). This can be either side of the mounting bush but its best to aim for the most accessible area on the Swaybar. If there is little room to physically tighten the lateral locks, it may be best to mark your Swaybar then remove from vehicle then attach the lateral locks prior to fitment.
2. Tighten the lateral lock bolts down evenly and use mild force to secure.
Note : Please don't over tighten.
3. After test driving the vehicle, recheck Swaybar position and adjust lateral locks if necessary.

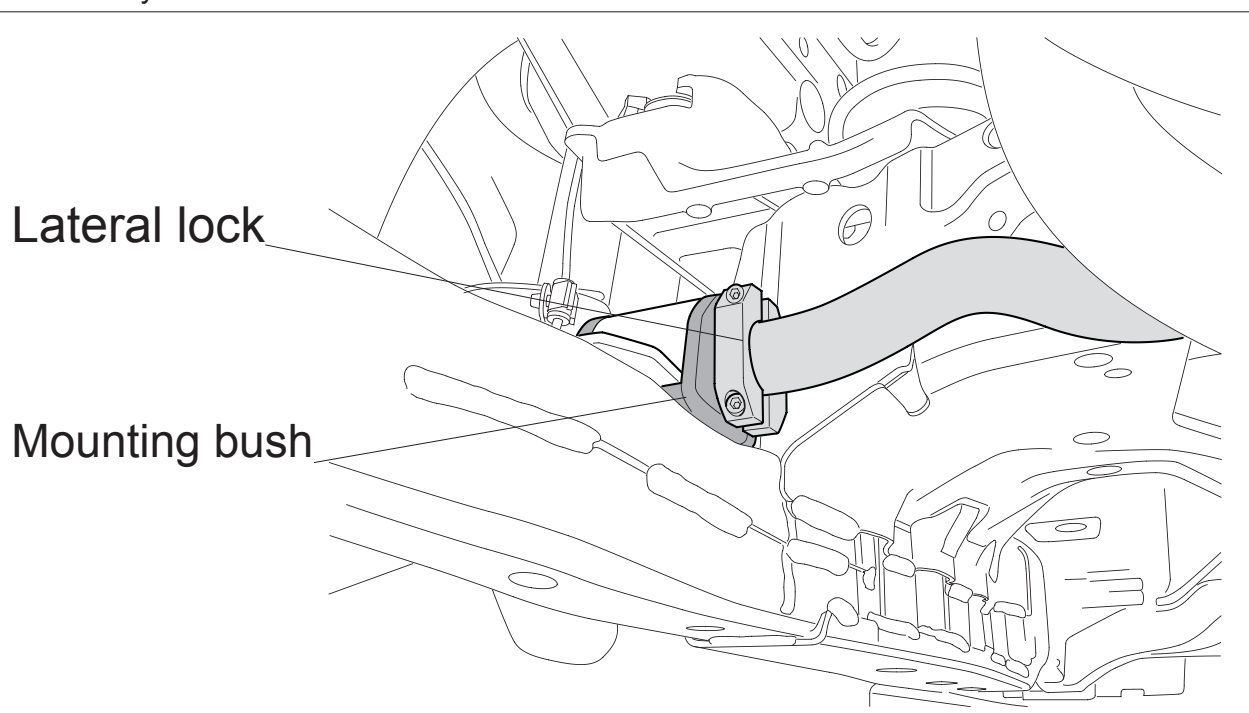

N.B: It is recommended that a licenced workshop or trades person carry out the above procedure and that workshop manual and relevant safety procedures are followed in addition to the above.