

(Always refer to the current catalogue for complete application listings)

N.B: This installation guide should be used in conjunction with the workshop manual.

1. Drive the vehicle up on ramps (if available) or alternatively raise the vehicle evenly on both sides and support with jack stands.
 2. Loosen and remove the existing OE sway bar links.
 3. Use a ruler or tape measure to check and confirm your OE link length.
 4. Please remember to leave at least 10mm of ball link thread in the lock nut, you can check this by completely removing the ball link and marking the thread. (REFER FIG 1)
 5. Once the length is determined, hand tighten all lock nuts with fingers. (REFER FIG 3)
- Note : Studs can point in any direction to suit application.
6. After installing one side check that the other link's studs line up with the sway bar and control arm holes. If you find the studs won't easily slide in then you now have the ability to fine tune the length of the adjustable ball link to remove any unwanted sway bar pre load.
 7. Once both links are installed and there are no visible clearance issues, then tighten all lock nuts with appropriate spanners.
 8. Check all fittings after test drive and recheck after initial 100km.

FIGURE 1

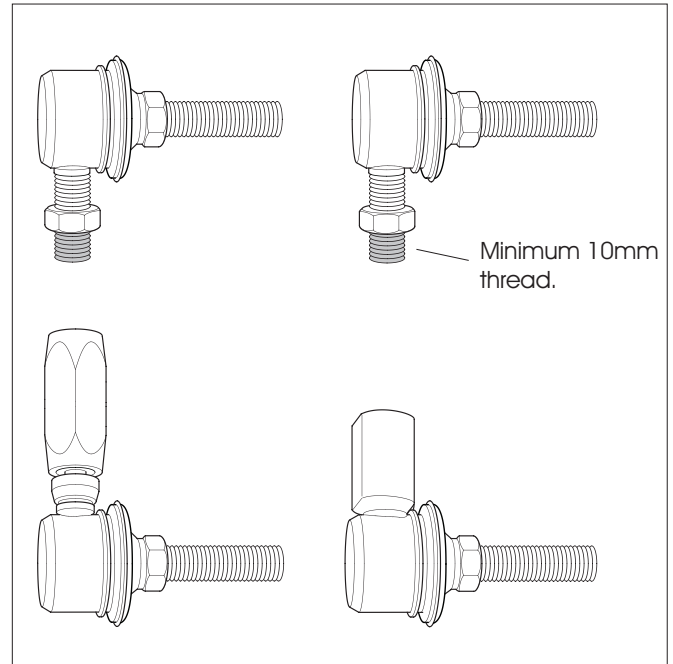

FIGURE 2

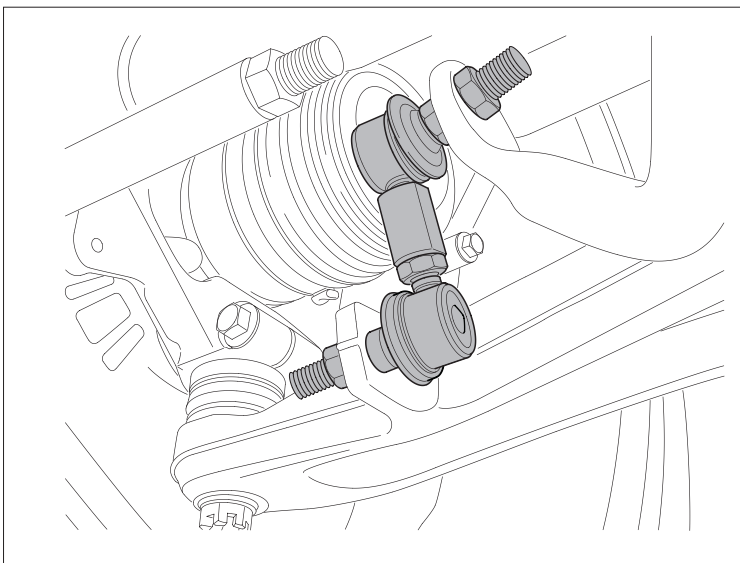
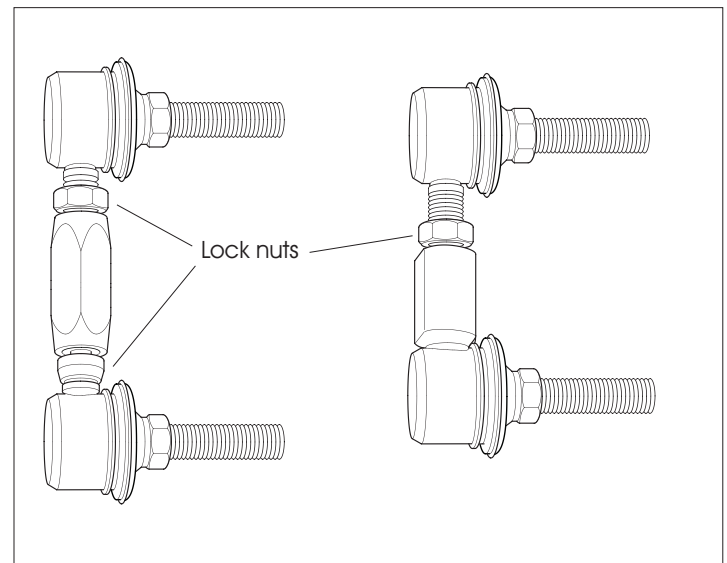

FIGURE 3



Warning: Please drive carefully after fitting any suspension modifications while you accustom yourself to the vehicles changed behaviour.

Note: It is recommended that a licensed workshop or trades person carry out the above procedure and that the workshop manual be used in conjunction with the above.

Installation Guide

Alloy Lateral Lock Kit

Z 5160

(Always refer to the current catalogue for complete application listings)

Alloy high performance lateral locks are designed to maintain Swaybar centralization.

1. Once you have your Swaybar in position and central with links attached, attach the lateral locks next to the mounting bush (leave approx 3-4mm gap). This can be either side of the mounting bush but its best to aim for the most accessible area on the Swaybar. If there is little room to physically tighten the lateral locks, it may be best to mark your Swaybar then remove from vehicle then attach the lateral locks prior to fitment.
2. Tighten the lateral lock bolts down evenly and use mild force to secure.
Note : Please don't over tighten.
3. After test driving the vehicle, recheck Swaybar position and adjust lateral locks if necessary.

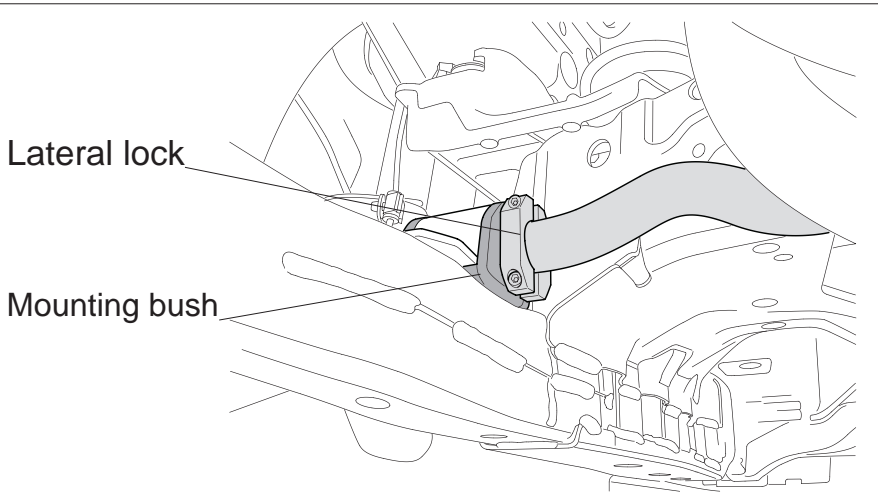

N.B: It is recommended that a licenced workshop or trades person carry out the above procedure and that workshop manual and relevant safety procedures are followed in addition to the above.

Rear Swaybar Kit

N.B: This instruction sheet should be used in conjunction with the workshop manual

WORK ORDER

1. Raise the vehicle evenly and support with jack stands then remove rear wheels.
2. Remove the 2 inner beam axle mounting bolts on either side of the vehicle (indicated in FIG.2) assemble the swaybar link mount placing the supplied 20mm (thick) crusstubes between the beam axle mount and the supplied swaybar link mount (spacing the supplied bracket away from the floorpan) using the supplied 90mm long bolts.
3. Place the supplied U bolts over the suspension beam axle, then secure the swaybar loosely using the supplied flat plates, urethane bushing's, bushing saddles and supplied nuts (as per FIG.1).
Ensure the internal bore of the bushing's are greased liberally and distance between the inside of the urethane bushings is approximately 605mm (as shown in FIG.3).
4. Mount swaybar links in place making sure the supplied small washers are between the nuts and the swaybar. Ensure the swaybar links are mounted into the softest hole on the swaybar (as indicated in FIG.2) until you are accustomed to the change in the vehicles suspension characteristics.
5. Ensure all mounting nuts and bolts are tight and secure before lowering vehicle down from jack stands and test driving.

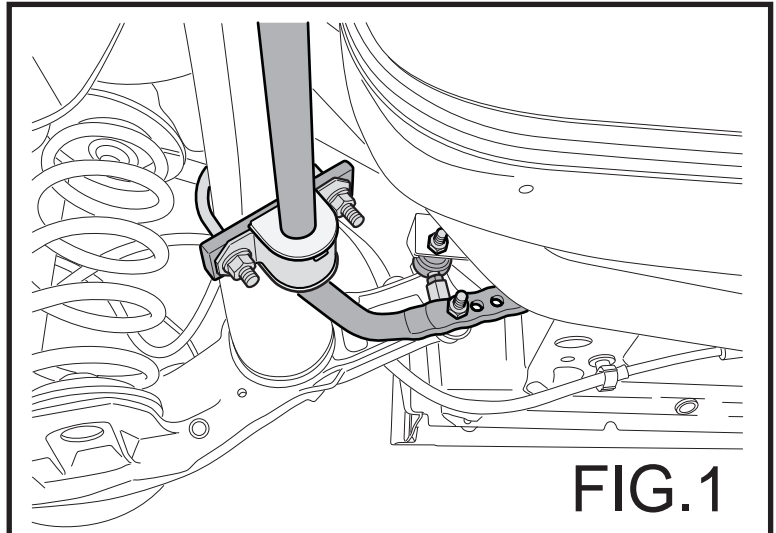

FIG.1

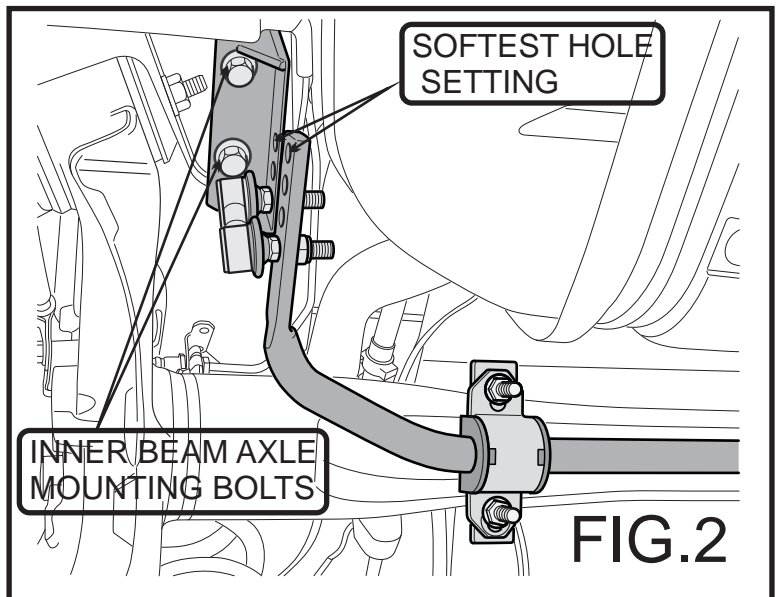

FIG.2

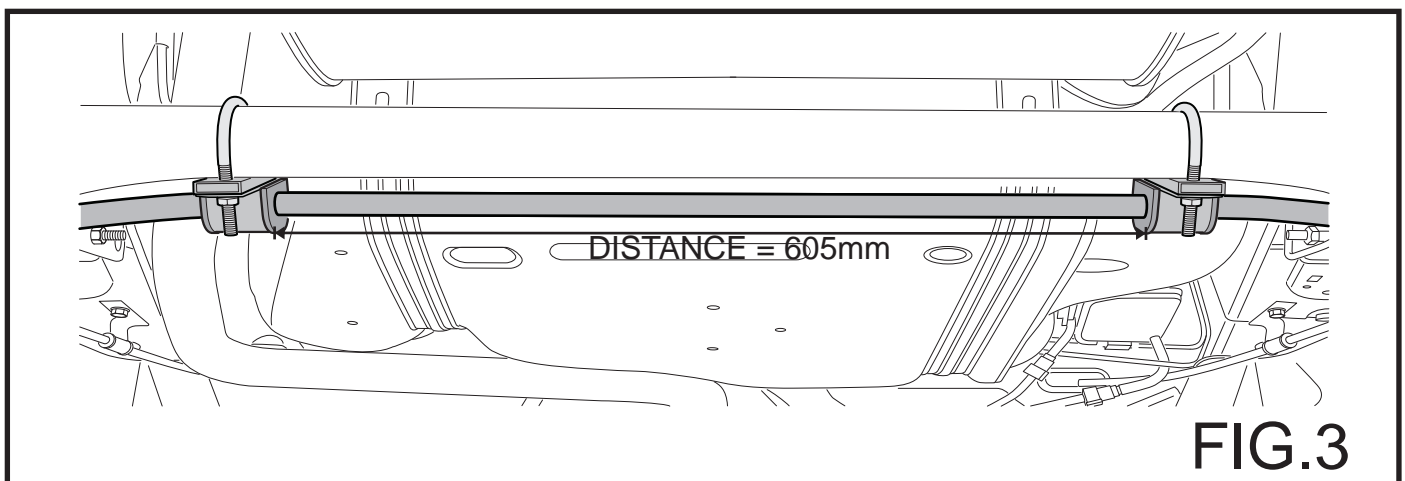

FIG.3

N.B: It is recommended that a licenced workshop or tradesperson carry out the above procedure and that workshop manual and relevant safety procedures are followed in addition to the above.