

Safety First

This document provides all the necessary information to allow your Whelen product to be properly and safely installed. Before beginning the installation and/or operation of your new product, the installation technician and operator must read this manual completely. Important information is contained herein that could prevent serious injury or damage.

- Proper installation of this product requires the installer to have a good understanding of automotive electronics, systems and procedures.
- If mounting this product requires drilling holes, the installer **MUST** be sure that no vehicle components or other vital parts could be damaged by the drilling process. Check both sides of the mounting surface before drilling begins. Also de-burr any holes and remove any metal shards or remnants. Install grommets into all wire passage holes.
- If this manual states that this product may be mounted with suction cups, magnets, tape or Velcro[®], clean the mounting surface with a 50/50 mix of isopropyl alcohol and water and dry thoroughly.
- Do not install this product or route any wires in the deployment area of your air bag. Equipment mounted or located in the air bag deployment area will damage or reduce the effectiveness of the air bag, or become a projectile that could cause serious personal injury or death. Refer to your vehicle owner's manual for the air bag deployment area. The User/Installer assumes full responsibility to determine proper mounting location, based on providing ultimate safety to all passengers inside the vehicle.
- For this product to operate at optimum efficiency, a good electrical connection to chassis ground must be made. The recommended procedure requires the product ground wire to be connected directly to the **NEGATIVE (-)** battery post.
- If this product uses a remote device to activate or control this product, make sure that this control is located in an area that allows both the vehicle and the control to be operated safely in any driving condition.
- Do not attempt to activate or control this device in a hazardous driving situation.
- This product contains either strobe light(s), halogen light(s), high-intensity LEDs or a combination of these lights. Do not stare directly into these lights. Momentary blindness and/or eye damage could result.
- Use only soap and water to clean the outer lens. Use of other chemicals could result in premature lens cracking (crazing) and discoloration. Lenses in this condition have significantly reduced effectiveness and should be replaced immediately. Inspect and operate this product regularly to confirm its proper operation and mounting condition. Do not use a pressure washer to clean this product.
- It is recommended that these instructions be stored in a safe place and referred to when performing maintenance and/or reinstallation of this product.
- **FAILURE TO FOLLOW THESE SAFETY PRECAUTIONS AND INSTRUCTIONS COULD RESULT IN DAMAGE TO THE PRODUCT OR VEHICLE AND/OR SERIOUS INJURY TO YOU AND YOUR PASSENGERS!**

IMPORTANT! The lightbar should be located a minimum of 16" from any radio antennas!

Permanent Mounting:

1. Locate the mounting foot and locking plate included with your lightbar. If not already present, install the locking plate onto the mounting foot. When properly positioned, this plate is centered from side to side on the mounting foot.
2. Flip the lightbar upside-down to expose the bottom of the extrusion and place the mounting foot onto the extrusion.
3. Rotate the mounting foot 90° in a counter-clockwise direction. Make sure that the edges of the mounting foot swing into position under the extrusion mounting lip.
4. Repeat this procedure for the remaining mounting foot and return the lightbar to its right side-up position.
5. Position the lightbar onto the vehicle roof in the desired mounting location. One often selected location is directly above the B-pillars. This area is the strongest part of the roof. Refer to your lightbar manual for cable exit location, to be sure that the lightbar is facing the proper direction.
6. Adjust the two mounting feet outwards so that they are as close to the edge of the roof as possible. Make sure that both mounting feet are in full contact with the roof. Be sure that there is no less than 1/2" clearance between the roof and the lightbar at their closest point. When the mounting feet are in their proper position, lightly tighten the locking plate allen head set screws.
7. Turn the lightbar upside down and firmly tighten all of the set screws from step 6 (2 or 4 per side).
8. On the adjustable foot, use the hole in the pad as a guide to drill the two holes into the mounting foot at the locations shown.

Strap Mounting:

1. Locate the mounting foot, anchor plate and locking plate included with your lightbar. If not already present, install the locking plate onto the mounting foot. When properly positioned, this plate is centered from side-to-side on the mounting foot.
2. Flip the lightbar upside-down to expose the bottom of the extrusion and place the mounting foot onto the extrusion.
3. Rotate the mounting foot 90° in a counter-clockwise direction. Make sure that the edges of the mounting foot swing into position under the extrusion mounting lip. Install an anchor plate onto the extrusion in the same manner.
4. Repeat this procedure for the remaining mounting foot and anchor plate and return the lightbar to its right side-up position.
5. Position the lightbar onto the vehicle roof in the desired mounting location. One often selected location is directly above the B-pillars. This area is the strongest part of the roof. Refer to your lightbar manual for cable exit location, to be sure that the lightbar is facing the proper direction.
6. Adjust the two mounting feet outwards so that they are as close to the edge of the roof as possible. Both mounting feet must be in full contact with the roof. Be sure that there is no less than 1/2" clearance between

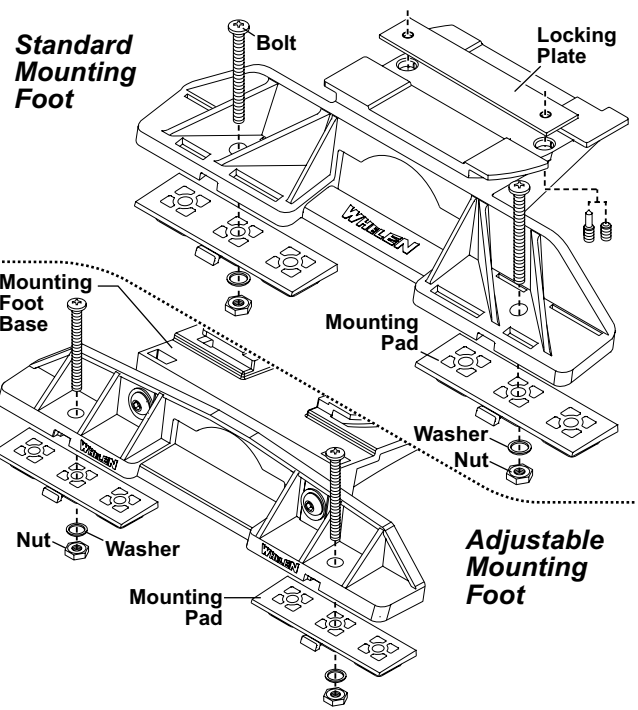

9. Place the lightbar in its final mounting position on the vehicle, mark the mounting hole locations off onto the mounting surface, remove the lightbar and drill the mounting holes.
10. Place the lightbar onto the vehicle lined up with the mounting holes and secure the mounting feet to the vehicle with supplied hardware.

roof and lightbar at their closest point. When the mounting feet are in their proper position, lightly tighten the locking plate allen head set screws.

7. Return the lightbar to an upside-down position. Slide each anchor plate outwards until it is fully engaged with its corresponding mounting foot. With the mounting feet and anchor plates in their proper positions firmly tighten all of the set screws (2 or 4 per side). Flip the lightbar right side-up and return it to its mounting position.
8. Open both drivers side doors. In the area directly below the mounting foot, pull the weatherstrip away from the vehicle so the area where the mounting strap will be secured is exposed. Repeat for the other side.
9. Insert the mounting strap through the mounting foot. Be sure that the strap fits flush against the area where it will be secured onto the vehicle. Insert the tension bolt through the mounting strap and anchor plate, into the tinnerman nut. Tighten slightly with a long-shafted, Phillips screwdriver. Repeat procedure for passenger side.
10. If your mounting strap has mounting holes in the end of the strap, use these holes as a template to drill appropriately sized pilot holes through the strap and into the vehicle. Repeat for passenger side of the vehicle.
11. Firmly tighten the tension bolts to secure the lightbar to the vehicle.

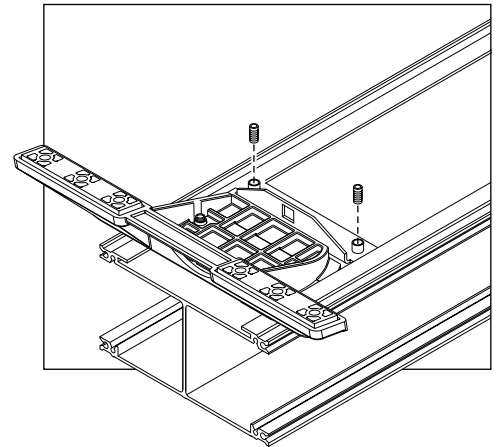
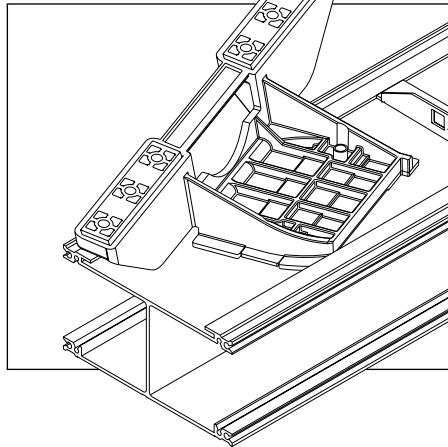
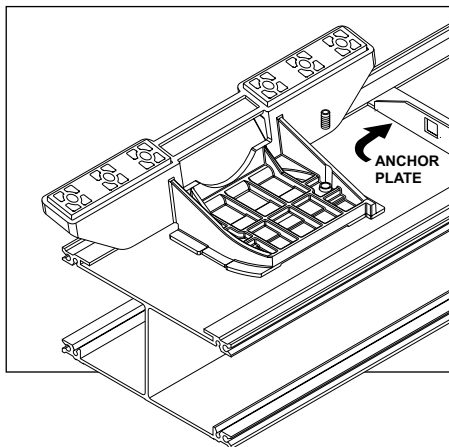

NOTE: Model MKAJ is an adjustable mounting foot. On this model you may loosen the screws on the rear of the foot and adjust the angle of the lightbar. To be used if the angle of the roof is not level with the road.

IMPORTANT: To adjust the leveling screws you must use a torque wrench set at 35 to 40 in./lbs.

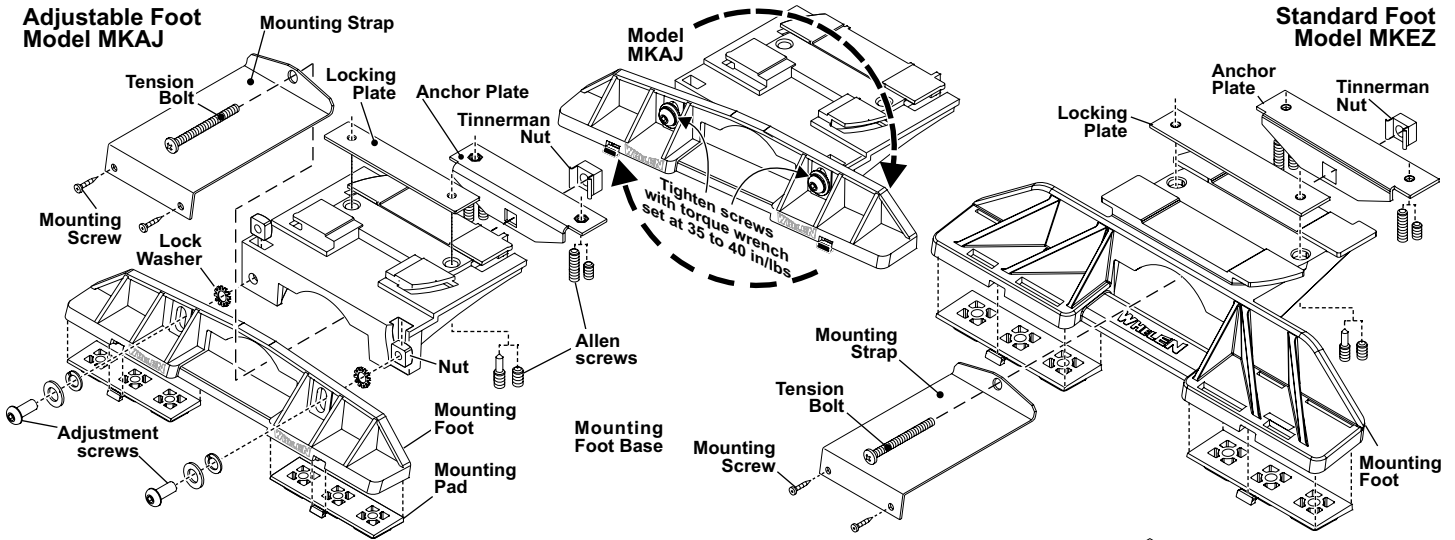

5" Mounting Foot

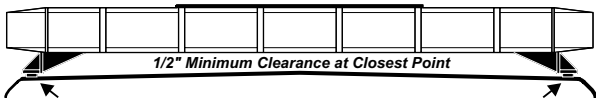
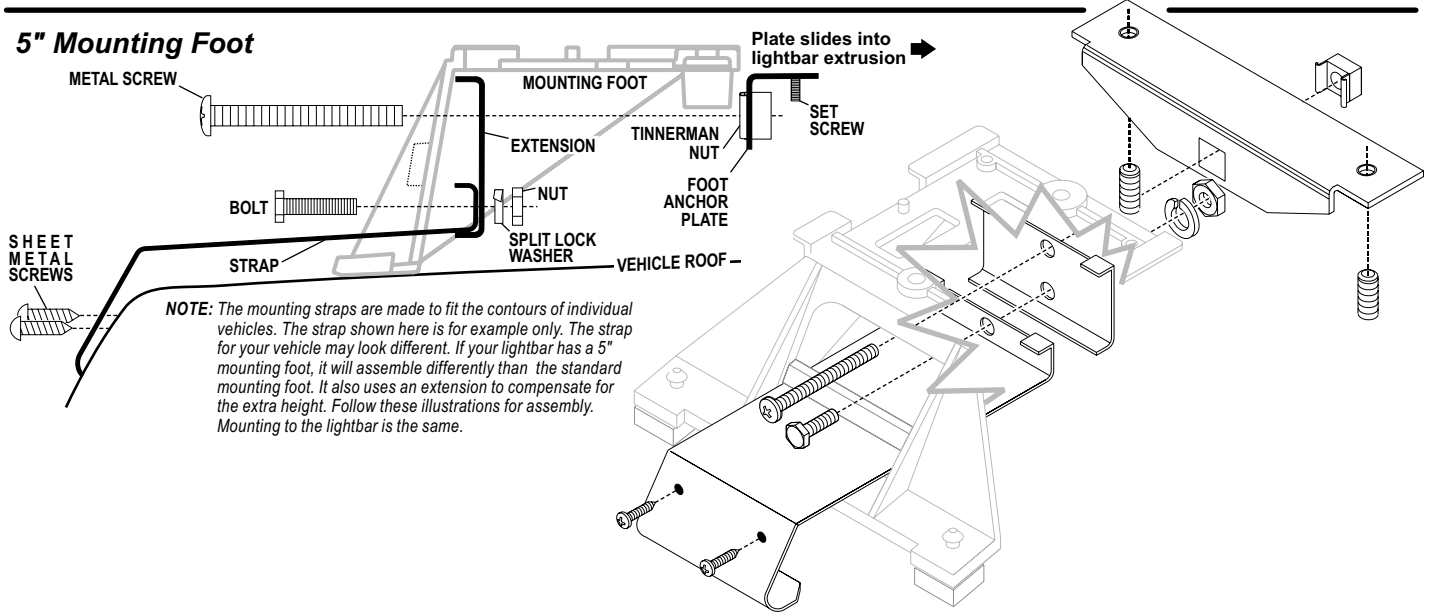

NOTE: Unless otherwise specified, the lightbar mounting feet must be sitting as close to the edge of the roof as possible. Mounting feet must also be in full contact with the roof and not be hanging off the edge.

IMPORTANT: For strap mounted bars, be sure you have the right sized lightbar for your vehicle. The lightbar should be about the same width as the vehicle roof. If the lightbar is too large or small it will not mount properly to the vehicle and may shift or come loose during driving.

Temporary Mounting (Magnetic, Suction Cup, etc.)

With the magnetic or magnetic/suction cup mounting options you will be able to mount your strobe so that you can remove it if necessary and avoid drilling.

Installation: Magnetic/suction

Thoroughly clean the proposed mounting surface prior to mounting. For suction cup mounting, wipe the suction cup clean, place the beacon onto its mounting surface and apply gentle pressure to ensure a good seal has been achieved. The Magnetic/Suction Cups mount the same way as standard suction cups but are best suited to a flat, steel surface.

Installation: Magnetic

Place beacon onto mounting surface and plug into vehicle cigar lighter.

Wiring:

Models featuring a cigar plug adaptor are simply plugged into your vehicles cigar lighter for a power connection. For models with an 11-conductor cable, the wire function chart below provides necessary wiring and fusing information.

WARNING! All customer supplied wires that connect to the positive terminal of the battery must be sized to supply at least 125% of the maximum operating current and FUSED at the battery to carry that load. DO NOT USE CIRCUIT BREAKERS WITH THIS PRODUCT!

11-Conductor Control Cable:

<u>WIRE</u>	<u>To</u>	<u>FUNCTION</u>	<u>Fuse Wire @</u>
RED	+12VDC	9M412 Power Supply	10 Amps
GREY	+12VDC	Activates Front Corner Strobes	1 Amp
WHITE-BLUE	+12VDC	Activates Rear Corner Strobes	1 Amp
WHITE	+12VDC	Powers Driver's Alley Light	5 Amps
YELLOW	+12VDC	Powers Passenger's Alley Light	5 Amps
WHITE-BLACK	+12VDC	Powers Take-Down Lights	10 Amps
WHITE-VIOLET	+12VDC	Powers Inboard Strobes	5 Amps
VIOLET	+12VDC	Activates Strobe Low Power	1 Amp
BLACK	Ground	9M412 Power Supply	N/A
BLACK-WHITE	Ground	Accessories	N/A
BLACK-YELLOW	Ground	CS225 Power Supply	N/A

Routing your Lightbar Cable:

1. To protect the headliner from damage caused by drilling the cable access hole, allow a 5" to 7" distance between roof and headliner by lowering the headliner before drilling.
2. Using a 1" hole saw, drill the cable access hole.

WARNING! There may be a roof support member that spans the distance between the driver's and passenger's side. DO NOT DRILL THROUGH THIS MEMBER! Adjust the location until the hole can be drilled without contacting this support.

3. Using a round file, smooth and de-burr the edges of the hole. Insert a 1" grommet (user supplied) into the cable access hole.
4. Insert the cable(s) through the cable access hole into the vehicle. Use RTV silicone to weatherproof the access hole after the cable is pulled completely into the vehicle.
5. Route the cable(s) one at a time to their respective destinations (power cable to vehicle battery; control cable to customer switch panel). It is left to the installation technician's discretion to select a path for these cables that will both protect the cables from possible damage and not interfere with the operation of any other vehicle components or equipment. Refer to the instructions included with your switches for switch wiring information.

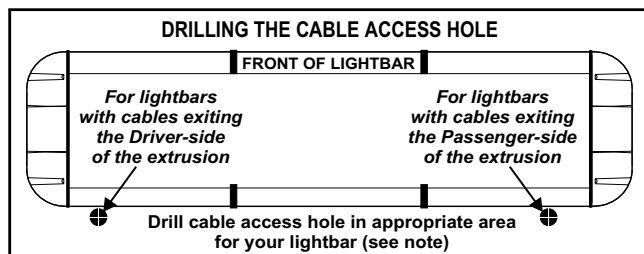

Internal Fuses:

Your lightbar has reverse polarity protection. If the lightbar will not turn on, inspect the internal fuse. If blown, disassemble the lightbar and replace with one of an identical rating (see diagram at right).

Maintenance:

If you need to add or replace lighthoods or filler panels or service your lightbar, the diagrams below will show you how to gain access to the lightbar.

WARNING! The strobe light power supply is a high voltage device. Do not remove the strobe tubes or dismantle the strobe lighthoods in the system while the unit is in operation. Wait 10 minutes after turning off power before starting work on the system.

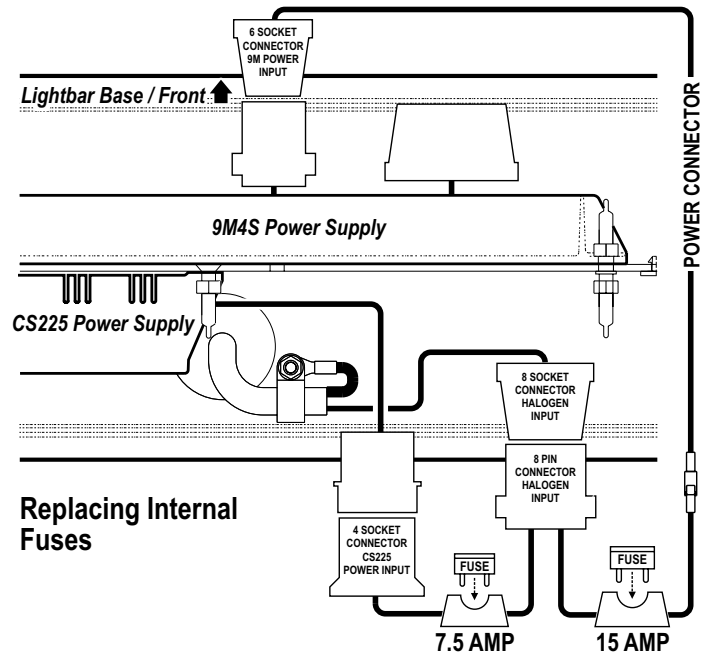

Mounting Lighthoods to Extrusion

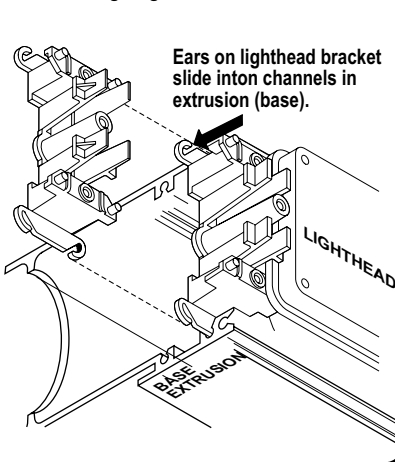

Lighthouse mounting holes snap into the raised bosses on the lighthouse bracket.

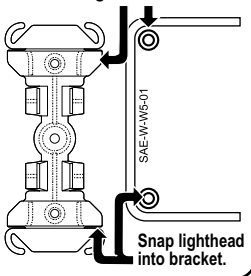

Installing a Corner Strobe

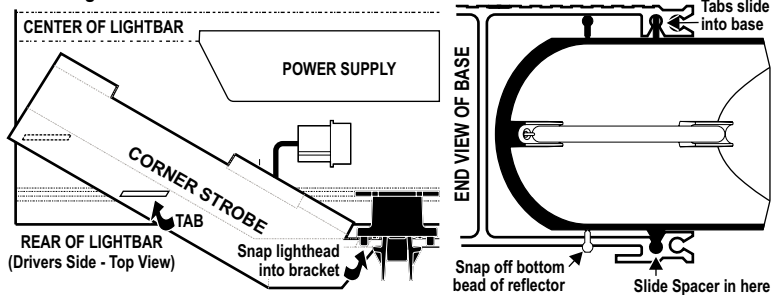

Before working on your strobe lights, disconnect the lightbar from power and remove the endcap. **WARNING:** The strobe light power supply is a high voltage device. Do not remove the strobe tubes or dismantle the strobe lighthoods in the system while the unit is in operation. Wait 10 minutes after turning off power before working on the system. To remove the lighthouse, unplug it from the mounting bracket, unplug it, and slide it out of the side of the lightbar base. If you are replacing the lighthouse, snap off the bottom bead on the new lighthouse as shown. Plug the new lighthouse into the lightbar, slide it into the base and snap it into the mounting bracket.

Endcap, Gasket, Lens & Spacer Installation

Remove the 4 screws (A) that hold the endcap (B) on and pull the endcap and gasket (C) off. Slide lenses (D) out of the lightbar, to gain access to the extrusion. When reinstalling the lenses and spacers, install the cord seal (NFPA). When reinstalling the endcap, place the endcap gasket into its position on the endcap and line up all the tabs and holes. Spacers (not shown) mount the same as lenses.

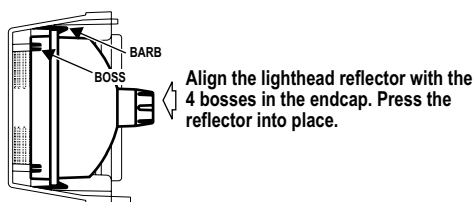
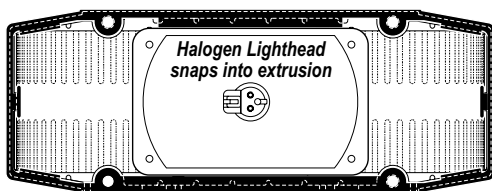

Seal Cord Installation / NFPA Only:

- 1 - Cut the seal cord approx. 1-1/2" longer than the extrusion on each side.
- 2 - Rub silicone over the cord seal leaving 3 to 4 inches on one end dry.
- 3 - Beginning with 1 corner lens, start the lens into the bottom lens track. Place the cord seal onto the groove in the top of the lens. Leave 1 to 2 inches free.
- 4 - Hold onto the left end of the seal hanging out and slide the corner lens into position.
- 5 - From the opposite end of the lightbar, pull the seal cord tight and install the remaining lenses and divider.

