



AUTOMOTIVE PRODUCTS,

INSTALLATION INSTRUCTIONS

HDX EXTREME BOARD

APPLICATION:

2009-2016 Dodge Ram 1500 Quad / Crew Cab
 2009-2016 Dodge Ram 2500/3500 Crew Cab
 (Excl. Cab Chassis w/D.E.F Tanks)

PART NUMBER:

56-23555, 56-23565

ITEM	QUANTITY	DESCRIPTION	TOOLS NEEDED
1	2	RUNNING BOARDS	13MM SOCKET
2,3	2	CENTER MOUNT BRACEKT, DRIVER(2) AND PASSENGER(3)	13MM WRENCH
4,5	2	FRONT MOUNT BRACKET, DRIVER(4) AND PASSENGER(5)	10MM SOCKET
6,7	2	REAR MOUNT BRACKET, DRIVER(6) AND PASSENGER(7)	ALLEN WRENCH
8	6	M10 BOLT / M8 NUT PLATE	DRILL
9	6	M8 HEX RIV-CERT (YELLOW ZINC)	SOCKET EXT.
10	6	M10 HEX NUT (YELLOW ZINC)	RATCHET
11	6	M10 SPLIT LOCK WASHER (YELLOW ZINC)	TORQUE WRENCH
12	6	M10 FLAT WASHER (YELLOW ZINC)	17MM SOCKET
13	24	M8 HEX HEAD CAP SCREW (YELLOW ZINC)	17MM WRENCH
14	24	M8 SPLIT LOCK WASHER (YELLOW ZINC)	LIGHT
15	24	M8 FLAT WASHER (YELLOW ZINC)	
16	2	M6 BUTTON HEAD CAP SCREW (BLACK ZINC)	
17	2	M6 SERRATED FLANGE NUT (BLACK ZINC)	
18	2	M6 FLAT WASHER (BLACK ZINC)	
19	6	M10 PLASTIC RETAINER SQUARE	

ANTI-SEIZE LUBRICANT MUST BE USED ON ALL STAINLESS STEEL FASTENERS TO PREVENT THREAD DAMAGE AND GALLING

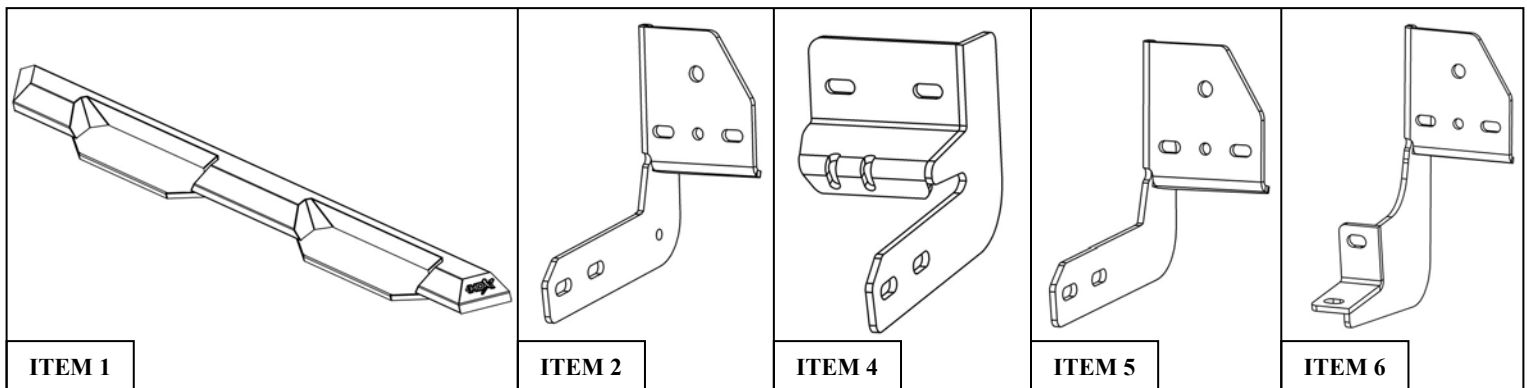

PROCEDURE

1. Remove contents from box, verify if all parts listed are present and free from damage.

Carefully read and understand all instructions before attempting installation.

Failure to identify damage before installation could lead to a rejection of any claim.

2. Check either side of the vehicles rocker panel, locate the factory holes in the rocker panel by removing the tape. Check and verify what type of rocker panel you have. **See Fig. 1, 2, 3, & 4.** **Note:** If any of the locations on the factory holes in the rocker panel have factory M8 riv-certs or threaded M8 holes, do not use provided M8 riv-certs (Item 9) at that location. **Refer to Fig. 1, 2, & 4.**

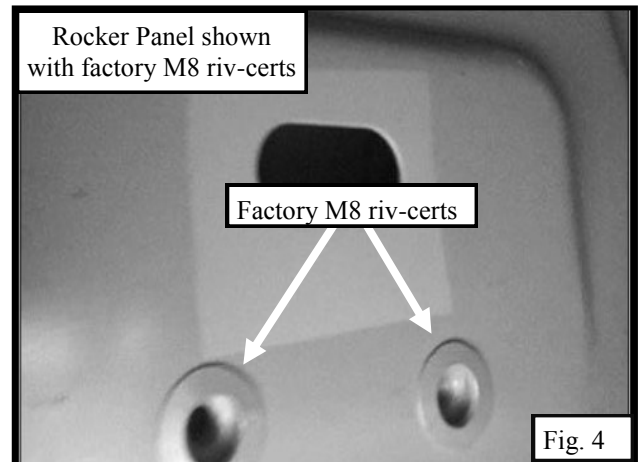
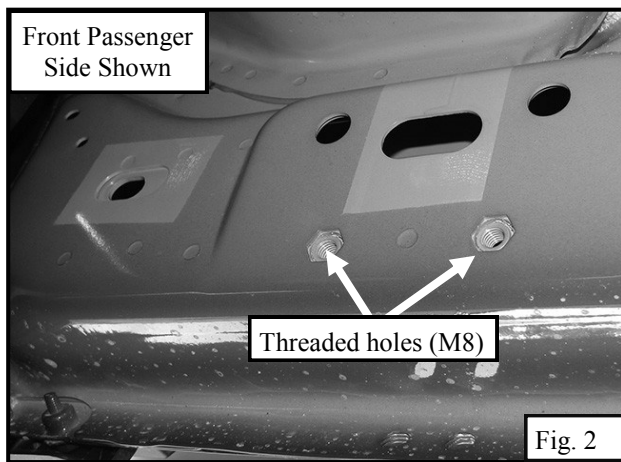
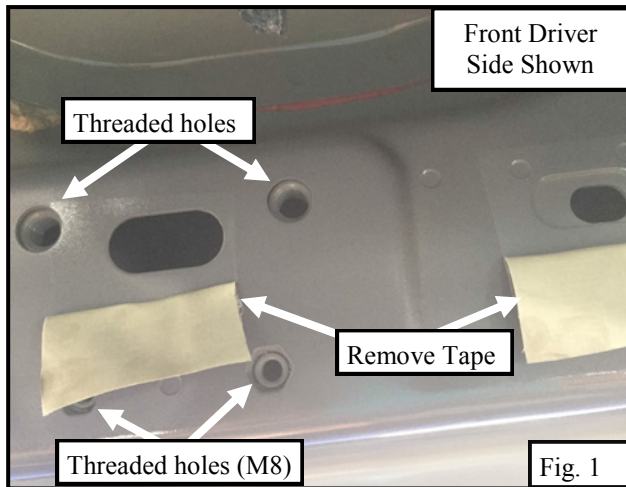

3. **Starting from the driver side:** If the threaded holes are not present use (1) M8 riv-certs (item 9) and insert one into the either hex hole. **Note:** See **Figure 6** for example on how to tighten M8 riv-certs, it will require to use an M10 bolt with M8 nut plate (Item 8) along with a bracket to perform this task. Use **Figure 7** on how to position (Item 8). This procedure will permanently install M8 riv-cert. Move item 8 to appropriate location, **See Figure 11.**
4. Proceed to install the front mounting bracket (Item 4) onto the rocker panel by using (2) M8 hex cap screws, (2) M8 lock washers, (2) M8 flat washers. For the pinch weld, attach bracket (item 4) by using the provided black zinc M6 hardware. **Note:** Drilling of two 1/4" holes might be necessary on pinch weld if factory holes are not present. Before drilling place masking tape on drill surface to prevent paint chipping.) **See Fig. 9 & 10.**

FOR NEWER MODELS

If the front of the rocker panel has pre-installed M8 riv-certs or M8 threaded holes, the M10/M8 plate (item 8) will need to be positioned as shown in **Figure 8**.

FOR OLDER MODELS

If the front rocker panel does not have pre-installed M8 riv-certs then (item 8) will be used as shown on **Figure 5 & 11**.

5. On the center and rear mounting locations of drivers side attach (1) M8 riv-cert to rocker panel if not already present. Then proceed to install (1) M10 bolt/M8 nut plate (Item 8) into the rocker panel and thread (1) M10 plastic retainer (Item 19) to the M10 bolt to prevent it from falling into the rocker panel. See **Figure. 5**.

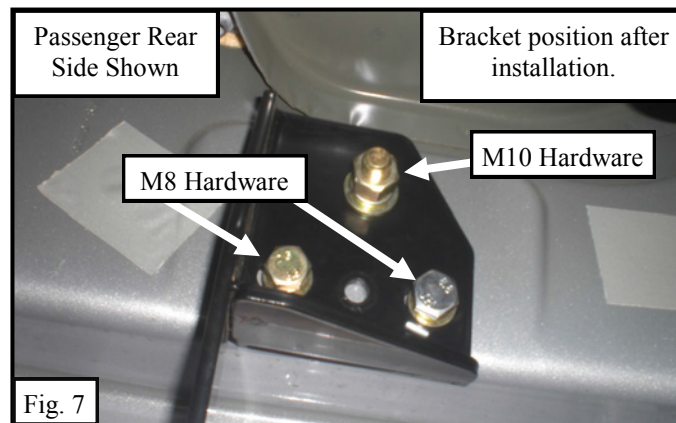
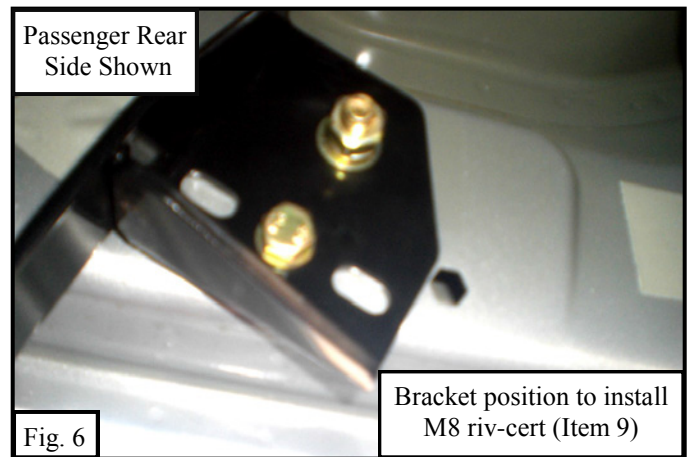
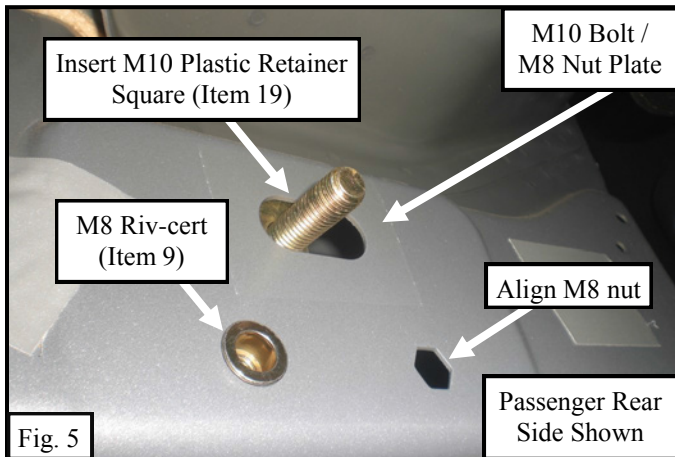

6. Loosely secure driver side center and rear mounting bracket (item 2 and 6) to the rocker panel in the center and rear mounting locations by aligning (item 9) (as shown on figure 5), using (2) M8 Hex bolts, (2) M8 Lock Washers, (2) M8 Flat washers, (1) M10 flat washer, (1) M10 lock washer, and (1) M10 Hex nut. Leave everything loose at this time. See **Figure. 7 & 11**.
7. **Starting from the Passenger side:** Insert (1) M10 bolt/M8 nut plate into the rocker panel and thread (1) M10 plastic retainer to the M10 bolt to prevent it from falling into the rocker panel. See **Figure. 5**.

8. If the front of the rocker panel has pre-installed M8 riv-certs, the M10/M8 plate (item 8) will need to be positioned as shown in **Figure 8**.
9. If the front rocker panel does not have pre-installed M8 riv-certs then (item 9) will be used as shown on **Figure 5 & 11**.
10. Attach passenger front, center, and rear passenger side mounting brackets to passenger side mount locations using the same procedure as step 6.

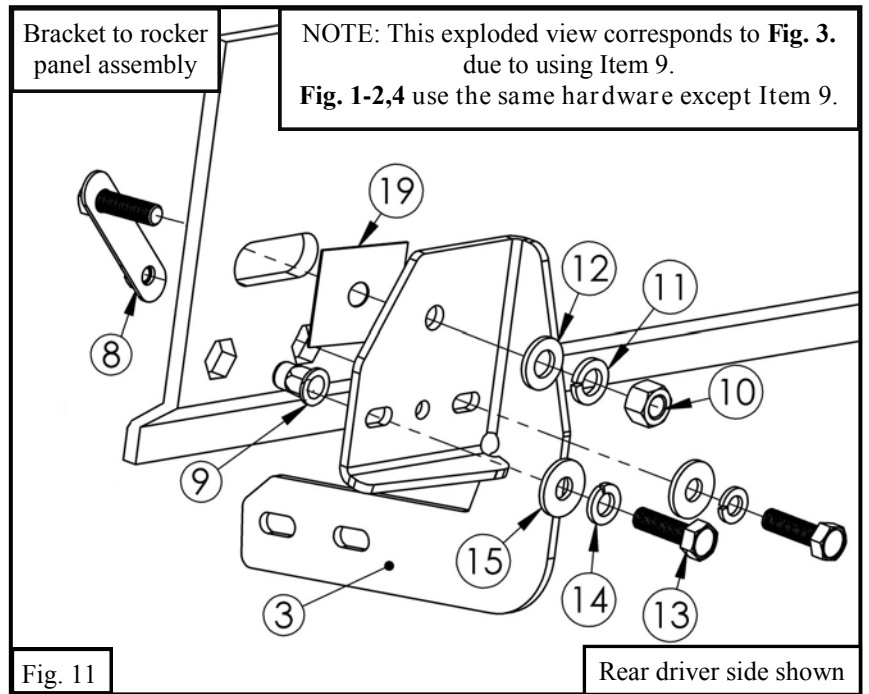
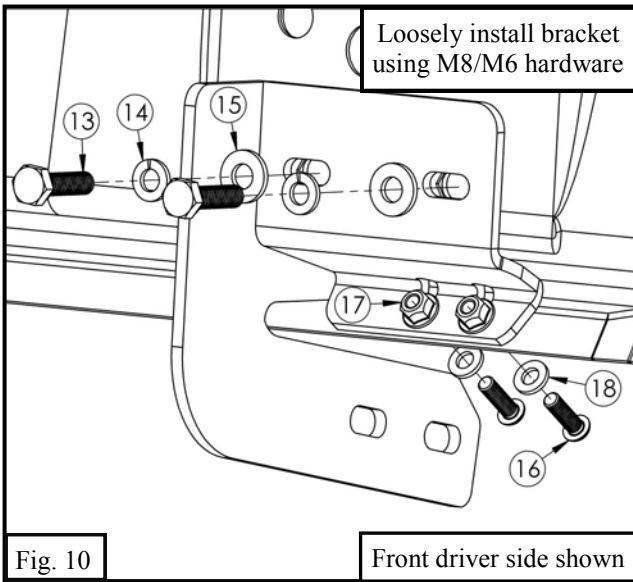
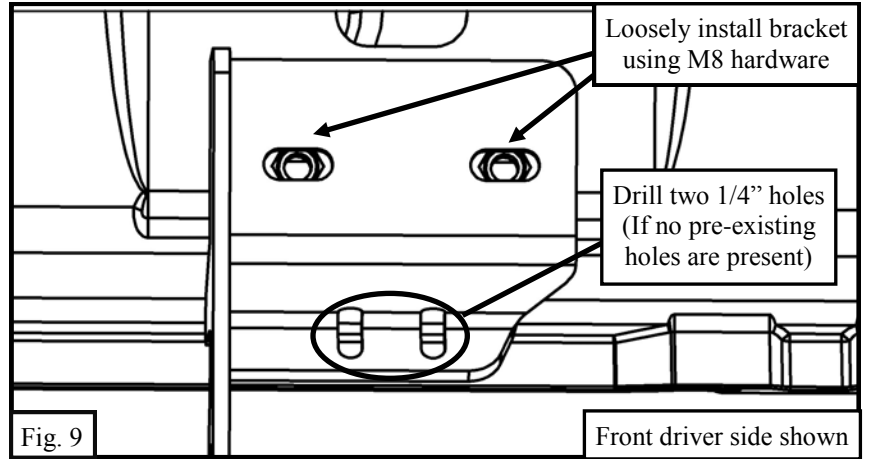
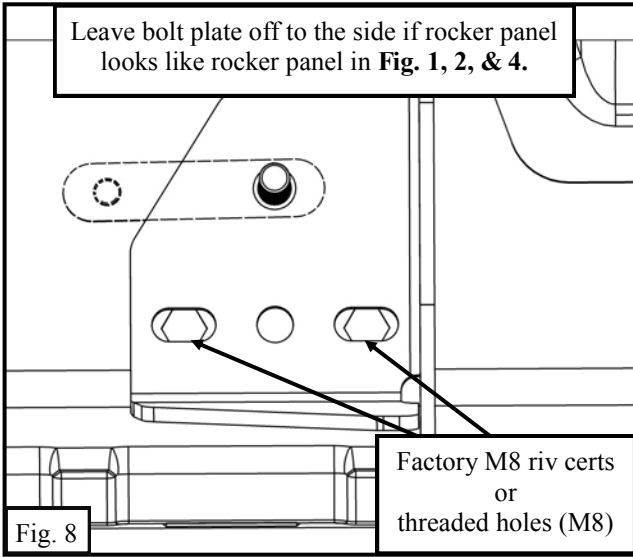

12. For Step Board installation to the previously installed mounting brackets use M8 bolts and supplied M8 hardware. See **Figure 12**.

13. Align and adjust the step bars and brackets as needed, then fully tighten all hardware: M10 to 35 ft-lbs, M8 to 20 ft-lbs,

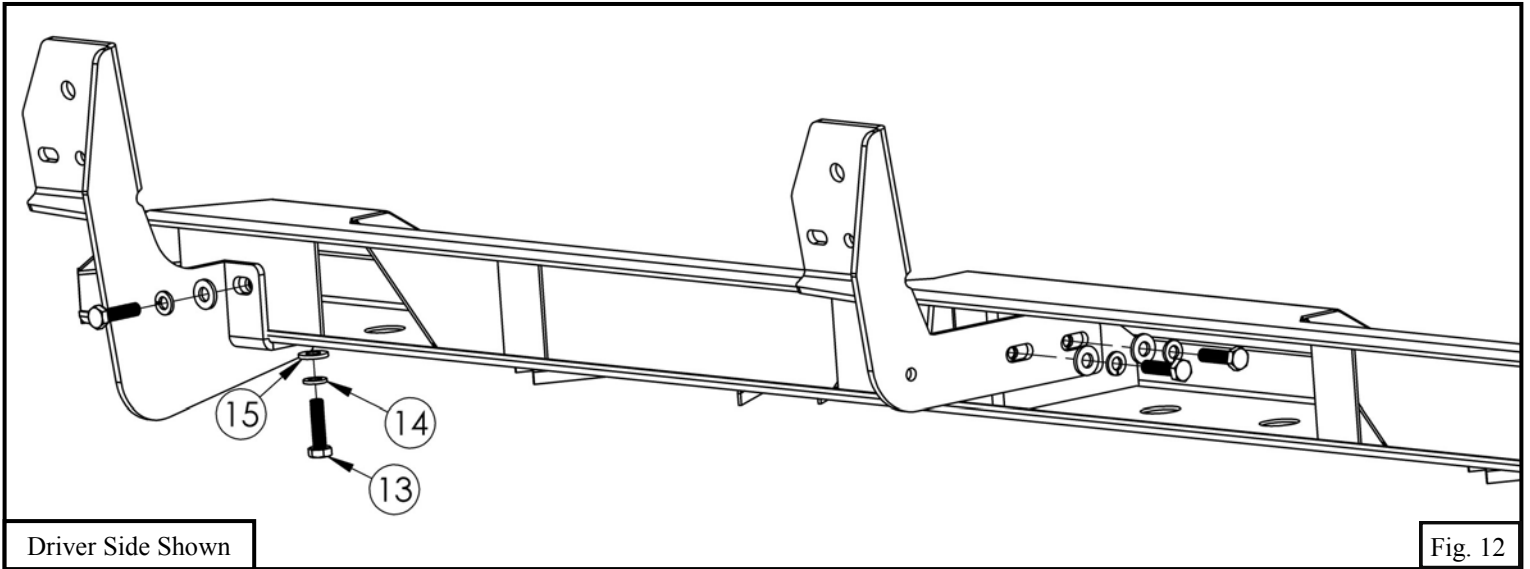

CARE INSTRUCTIONS

- REGULAR WAXING IS RECOMMENDED. DO NOT USE ANY TYPE OF POLISH OR WAX THAT MAY CONTAIN ABRASIVES.
- STAINLESS STEEL PRODUCTS CAN BE CLEANED WITH MILD SOAP AND WATER. STAINLESS STEEL POLISH SHOULD BE USED TO POLISH SMALL SCRATCHES.
- GLOSS BLACK FINISHES SHOULD BE CLEANED WITH MILD SOAP AND WATER.

Westin

SIGNATURE OF QUALITY

AUTOMOTIVE PRODUCTS, INC.



WARNING



Failure to follow these instructions could lead to death, personal injury, and / or property damage.

FASTENERS:

All Westin supplied fasteners must be utilized and installed in accordance with the installation instructions and apply torque to the specifications as defined. **DOUBLE CHECK ALL FASTENERS BEFORE INITIAL USE, AND PERIODICALLY IN THE FUTURE TO ENSURE PROPER FUNCTION AND SAFETY.**

DRILLING:

Most Westin products do not require drilling for installation. If drilling is defined as required, use caution when drilling a vehicle. **FAILURE TO REVIEW AN AREA TO BE DRILLED MAY RESULT IN PERSONAL INJURY AND/OR INJURY TO OTHERS AS WELL AS VEHICLE DAMAGE.**

EYE PROTECTION:

ALWAYS WEAR SAFETY GLASSES OR GOGGLES DURING THE INSTALLATION PROCESS TO AVOID PERSONAL INJURY.

MAXIMUM TOWING/CARRYING CAPACITY:

The Westin Receiver Hitches will have a visible tow rating label affixed directly on the product. User should never exceed the vehicle manufacturers maximum tow and weight rating regardless of the capacity of the hitch. **FAILURE TO FOLLOW THESE GUIDELINES WILL VOID THE WESTIN WARRANTY AND MAY RESULT IN PERSONAL INJURY AND/OR INJURY TO OTHERS AS WELL AS VEHICLE DAMAGE.**

Check out the collection of side steps and nerf bars we offer.