



AUTOMOTIVE PRODUCTS,

INSTALLATION INSTRUCTIONS

HDX DROP STEP

APPLICATION:
2007-2016 Toyota Tundra Crew Max

PART NUMBER:
56-13255

CONTENT			
ITEM	QUANTITY	DESCRIPTION	TOOLS NEEDED
1	2	STEP BAR ASSEMBLY	13MM SOCKET
2	2	FRONT MOUNTING BRACKET	13MM WRENCH
3	2	REAR MOUNTING BRACKET	RATCHET
4	2	CENTER MOUNTING BRACKET (HAS NOTCH)	TORQUE WRENCH
5	12	SHORT M8 HEX HEAD CAP SCREW (YELLOW ZINC)	SOCKET EXT.
6	12	LONG M8 HEX HEAD CAP SCREW (YELLOW ZINC)	
7	24	M8 SPLIT LOCK WASHER (YELLOW ZINC)	
8	24	M8 FLAT WASHER (YELLOW ZINC)	

ANTI-SEIZE LUBRICANT MUST BE USED ON ALL STAINLESS STEEL FASTENERS TO PREVENT THREAD DAMAGE AND GALLING

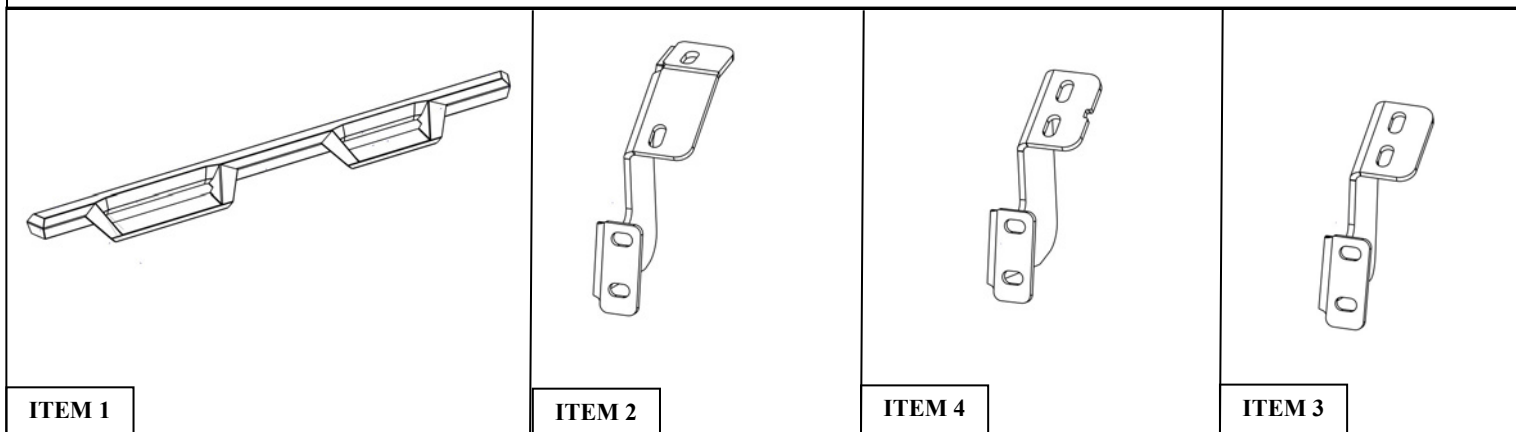

PROCEDURE

1. Remove contents from box, verify if all parts listed are present and free from damage.
Carefully read and understand all instructions before attempting installation.
Failure to identify damage before installation could lead to a rejection of any claim.

2. Start installation on either side of the vehicle. Locate mounting locations with factory threaded holes with screws or caps installed in them. Remove factory screws or caps from threaded holes, factory screws will not be used again. Locate (1) Front Mounting Bracket and loosely install it to the front mounting location on the rocker panel using (2) M8 hex head cap screw, (2) M8 split lock washer, and (2) M8 flat washer (Items 6-8). Locate the Center/Rear Mounting bracket (Items 3 & 4) and loosely secure in the correct mounting locations on the rocker panel. Loosely install using the provided M8 hardware (Items 6-8). **See Figure. 1.** (NOTE: See page 3 for bracket orientation)
3. Repeat Step 2 for the other vehicle side.
4. Tilt Board at angle to insert brackets into mounting locations. **See Figure 2**

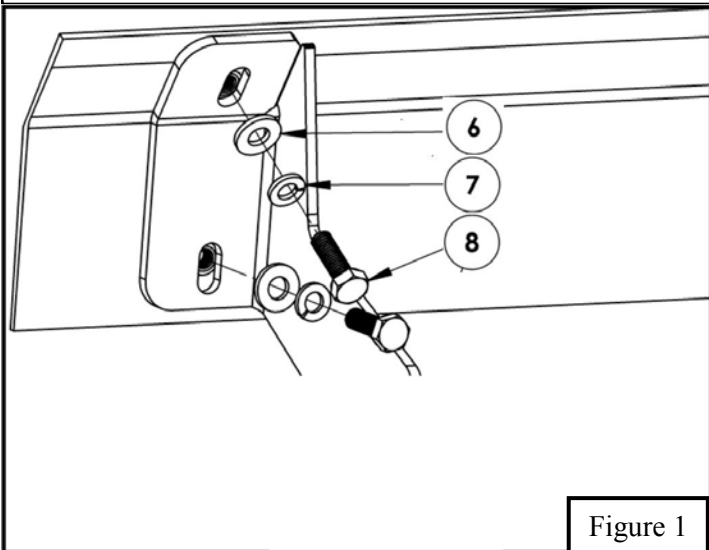

Figure 1

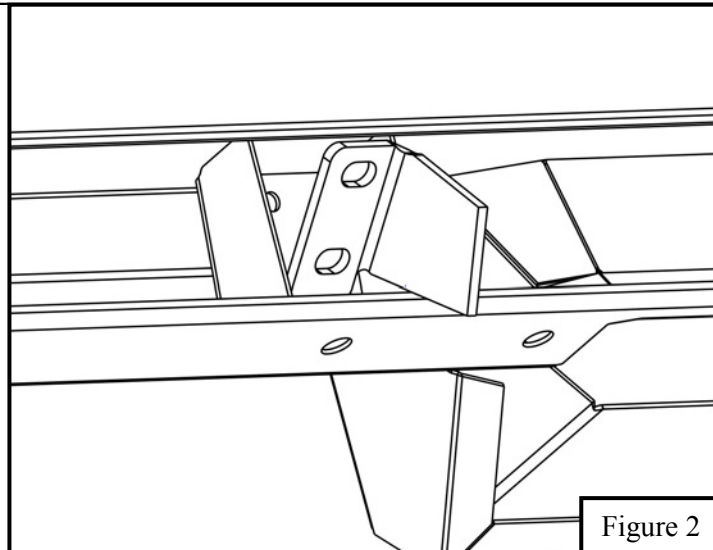

Figure 2

5. For Step Board installation to the previously installed mounting brackets use the supplied M8 hardware. **See Figure 3.**
6. Align step board and brackets to desired positioning then torque and tighten all: M8 hardware to 20 ft-lbs.

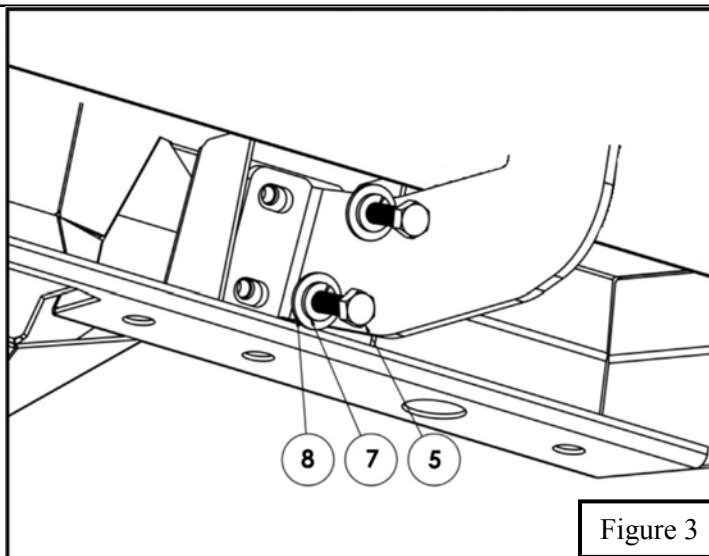
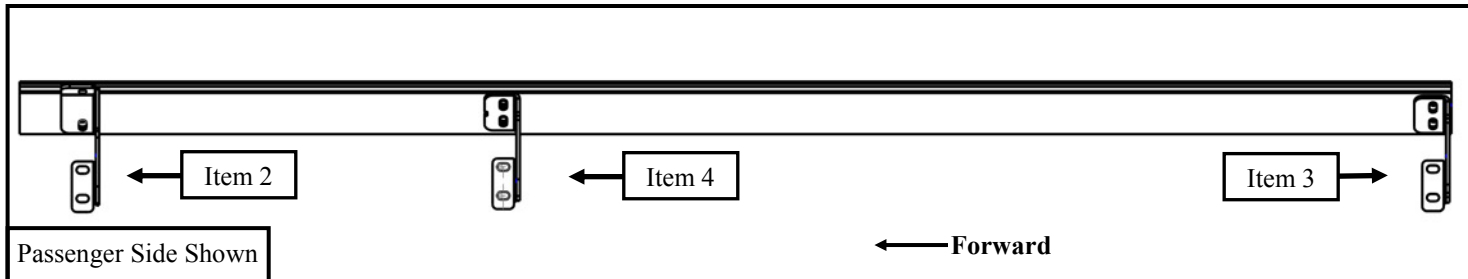

Figure 3



INSTALLATION COMPLETE



Care Instructions

- REGULAR WAXING IS RECOMMENDED. DO NOT USE ANY TYPE OF POLISH OR WAX THAT MAY CONTAIN ABRASIVES.
- STAINLESS STEEL PRODUCTS CAN BE CLEANED WITH MILD SOAP AND WATER. STAINLESS STEEL POLISH SHOULD BE USED TO POLISH SMALL SCRATCHES.
- GLOSS BLACK FINISHES SHOULD BE CLEANED WITH MILD SOAP AND WATER.

Westin

SIGNATURE OF QUALITY

AUTOMOTIVE PRODUCTS, INC.



WARNING



Failure to follow these instructions could lead to death, personal injury, and / or property damage.

FASTENERS:

All Westin supplied fasteners must be utilized and installed in accordance with the installation in-structions and apply torque to the specifications as defined. **DOUBLE CHECK ALL FASTENERS BEFORE INITIAL USE, AND PERIODICALLY IN THE FUTURE TO ENSURE PROPER FUNCTION AND SAFETY.**

DRILLING:

Most Westin products do not require drilling for installation. If drilling is defined as required, use caution when drilling a vehicle. **FAILURE TO REVIEW AN AREA TO BE DRILLED MAY RESULT IN PERSONAL INJURY AND/OR INJURY TO OTHERS AS WELL AS VEHICLE DAMAGE.**

EYE PROTECTION:

ALWAYS WEAR SAFETY GLASSES OR GOGGLES DURING THE INSTALLATION PROCESS TO AVOID PERSONAL INJURY.

MAXIMUM TOWING/CARRYING CAPACITY:

The Westin Receiver Hitches will have a visible tow rating label affixed directly on the product. Us-er should never exceed the vehicle manufacturers maximum tow and weight rating regardless of the capacity of the hitch. **FAILURE TO FOLLOW THESE GUIDELINES WILL VOID THE WESTIN WARRANTY AND MAY RESULT IN PERSONAL INJURY AND/OR INJURY TO OTHERS AS WELL AS VEHICLE DAMAGE.**

Shop for quality Westin products on our website.

Accept no compromises, choose only quality side steps and nerf bars.