



INSTALLATION INSTRUCTIONS

R7 Step Board

AUTOMOTIVE PRODUCTS,

APPLICATION:

1999-2015 Ford F150 Super Duty Super Cab/ Super Duty Super Crew

PART NUMBER:

28-71100, 28-71105, 28-71110, 28-71115

CONTENT			
ITEM	QUANTITY	DESCRIPTION	TOOLS NEEDED
1	2	STEP BAR ASSEMBLY	RATCHET
2	6	MOUNTING BRACKET	TORQUE WRENCH
3	2	FRONT SPACER PLATE	10MM SOCKET
4	6	PLASTIC BRACKET COVER	13MM SOCKET
5	10	M8 EXTRUDED U-NUT (YELLOW ZINC)	
6	12	M6 HEX HEAD CAP SCREW (YELLOW ZINC)	
7	24	M6 FLAT WASHER (YELLOW ZINC)	
8	12	M6 NYLON LOCK NUT (YELLOW ZINC)	
9	12	M8 HEX NUT (BLACK ZINC)	
10	12	M8 BUTTON HEAD CAP SCREW (BLACK ZINC)	
11	12	M8 SPLIT LOCK WASHER (BLACK ZINC)	
12	24	M8 SMALL FLAT WASHER (BLACK ZINC)	
13	22	M8 HEX HEAD CAP SCREW (BLACK ZINC) SEMS HARDWARE	
14	22	M8 SPLIT LOCK WASHER (BLACK ZINC) SEMS HARDWARE	
15	22	M8 LARGE FLAT WASHER (BLACK ZINC) SEMS HARDWARE	

ANTI-SEIZE LUBRICANT MUST BE USED ON ALL STAINLESS STEEL FASTENERS TO PREVENT THREAD DAMAGE AND GALLING

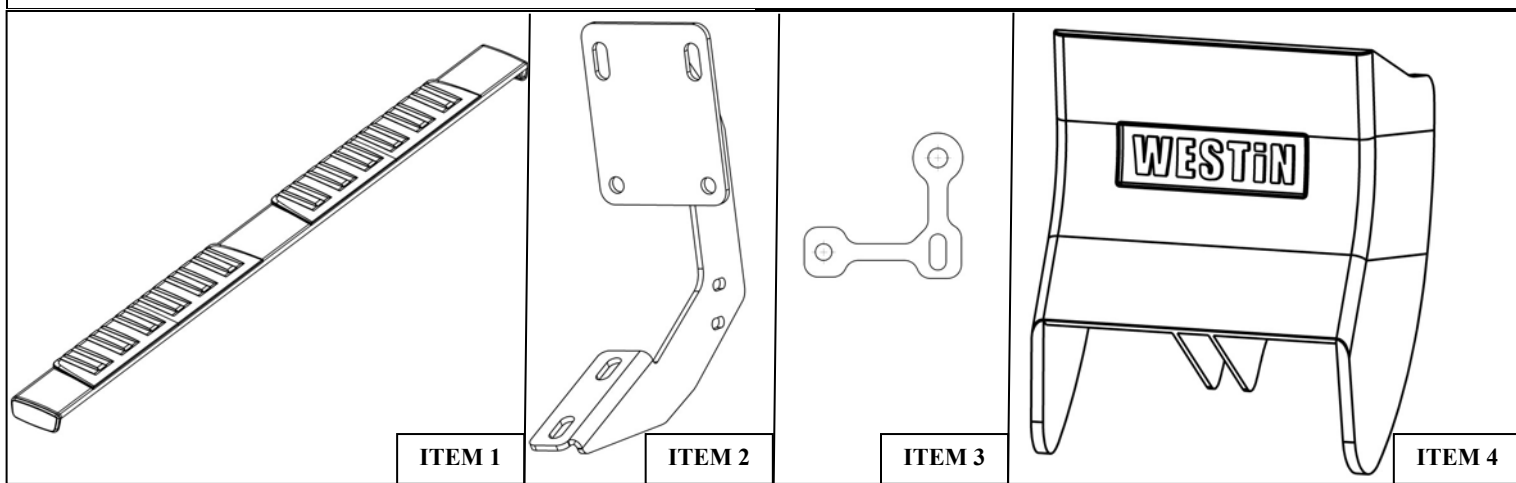

PROCEDURE

1. Remove contents from box, verify if all parts listed are present and free from damage. Carefully read and understand all instructions before attempting installation.
Failure to identify damage before installation could lead to a rejection of any claim.

2. Start installation on driver's side. On the rocker panel find locations with open holes and insert in the top open holes (2) M8 nut clips (Item 5). **NOTE: ON SOME VEHICLES THE MOUNTING HOLES DO NOT LINE UP FROM THE FACTORY IF THIS IS THE CASE DRILL OUT THE HOLES USING A 7/16" DRILL BIT**
3. Then loosely install SEMS hardware to previously installed Nut Clip; (2) M8 hex head bolts, (2) M8 flat washers, (2) M8 split lock washers. For installing to bottom open holes of the rocker panel, loosely install, (2) M8 button head bolts, (4) M8 flat washers, (2) M8 split lock washers, (2) M8 hex nuts. Repeat the same procedure for all other mounting locations. See **Figure 1**.
4. Note: For 2010– up model years place (1) front mounting bracket spacer (Item 3) in between the rocker panel and the front mounting bracket before installing. See **Figure 2**

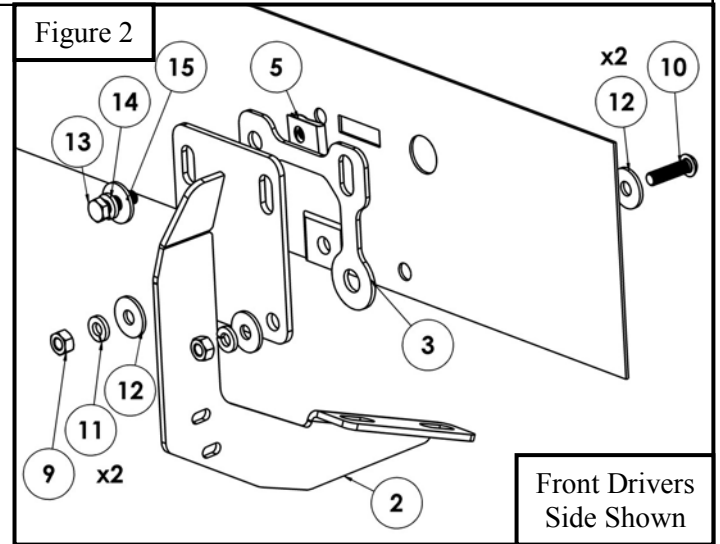
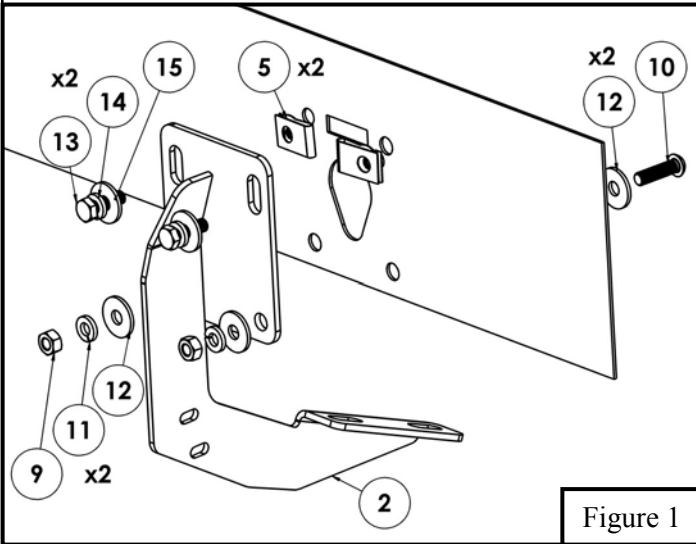

4. Locate (1) Plastic Bracket Cover (Item 4) and loosely secure it to the (6) brackets using the provided hardware: (2) M6 hex head bolt, (4) M6 flat washer, and (2) M6 nylon lock nut. Repeat for every bracket. See **Figure 3**.
5. Loosely install the Step Bar Assembly (Item 1) to the previously install mounting brackets with the supplied M8 hardware. See **Figure 4**.
6. Align step bar and brackets to desired positioning then torque and tighten all: M8 hardware to 20 ft-lbs and M6 hardware to 12 ft-lbs.

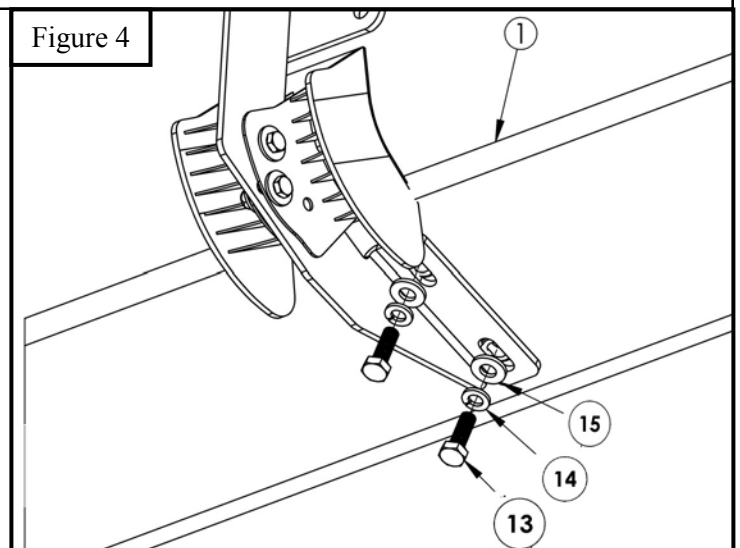
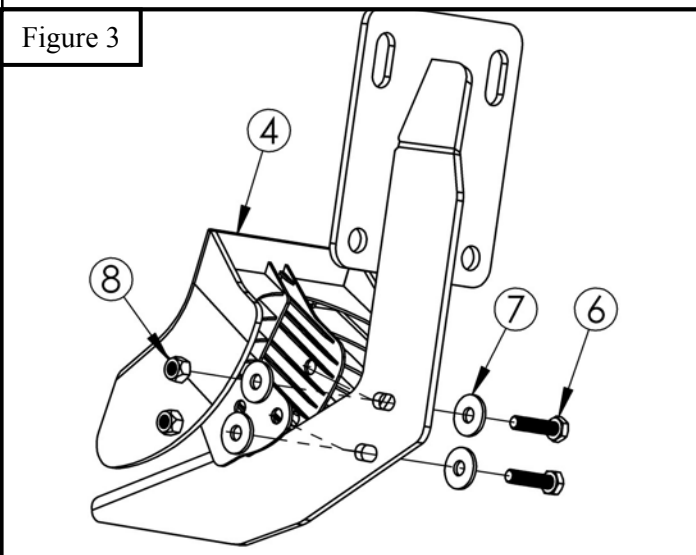

7. Below are Figures representing the orientation and positioning of the brackets for Crew Cab and Ext. Cab trucks. See **Figure 4 and 5**

Figure 4

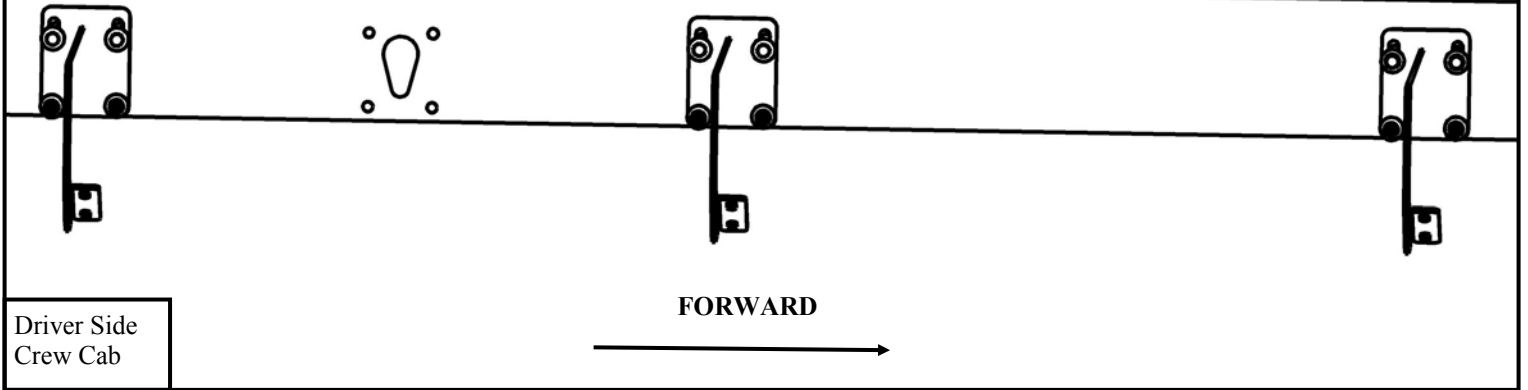
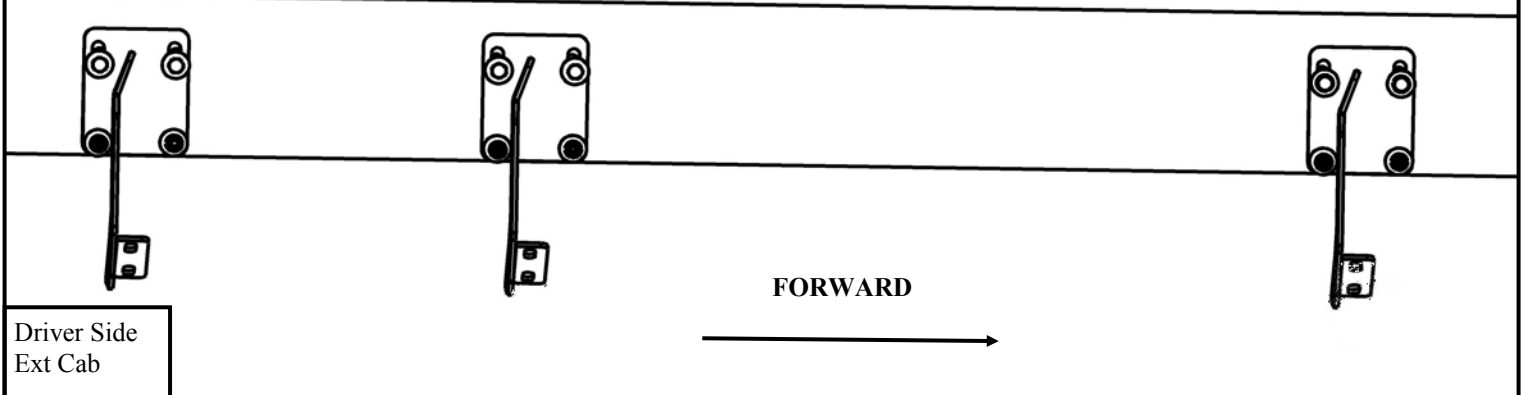

Figure 5



INSTALLATION COMPLETED



Ext Cab



Crew Cab

Care Instructions

- REGULAR WAXING IS RECOMMENDED. DO NOT USE ANY TYPE OF POLISH OR WAX THAT MAY CONTAIN ABRASIVES.
- STAINLESS STEEL PRODUCTS CAN BE CLEANED WITH MILD SOAP AND WATER. STAINLESS STEEL POLISH SHOULD BE USED TO POLISH SMALL SCRATCHES..
- GLOSS BLACK FINISHES SHOULD BE CLEANED WITH MILD SOAP AND WATER.