



# INSTALLATION INSTRUCTIONS

R7 Step Board

**APPLICATION:**

2007-2015 Chevy Silverado / GM Sierra / 1500-2500-3500

AUTOMOTIVE PRODUCTS,

**PART NUMBER:**

28-71020, 28-71025, 28-71030, 28-71035

CONTENT			
ITEM	QUANTITY	DESCRIPTION	TOOLS NEEDED
1	2	STEP BAR ASSEMBLY	RATCHET
2	5	MOUNTING BRACKET A	TORQUE WRENCH
3	6	PLASTIC BRACKET COVER	10MM SOCKET
4	24	M8 HEX HEAD BOLT (BLACK ZINC) <b>COMBO HARDWARE</b>	13MM SOCKET
5	24	M8 FLAT WASHER (BLACK ZINC) <b>COMBO HARDWARE</b>	
6	24	M8 LOCK WASHER (BLACK ZINC) <b>COMBO HARDWARE</b>	
7	12	M8 U-NUT CLIP (YELLOW ZINC)	
8	11	M6 HEX HEAD BOLT (YELLOW ZINC)	
9	22	M6 FLAT WASHER (YELLOW ZINC)	
10	11	M6 NYLOCK NUT (YELLOW ZINC)	
11	1	MOUNTING BRACKET B	

**ANTI-SEIZE LUBRICANT MUST BE USED ON ALL STAINLESS STEEL FASTENERS TO PREVENT THREAD DAMAGE AND GALLING**

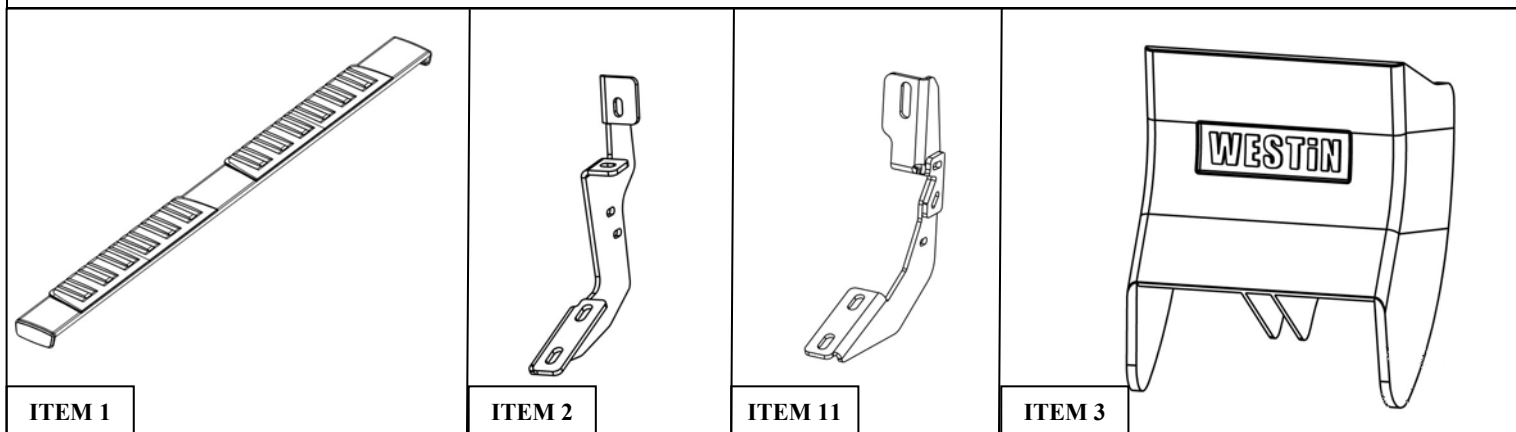

**PROCEDURE**

1. Remove contents from box, verify if all parts listed are present and free from damage.  
Carefully read and understand all instructions before attempting installation.  
**Failure to identify damage before installation could lead to a rejection of any claim.**

1. Starting on the driver side, remove the rubber plugs located on the rocker panel at each mounting location. See **Fig. 1**.
2. **For HD models:** At each bracket mounting location on the pinch weld there should either be a welded factory nut or a hole. If there is a factory welded nut present then the M8 U-Nut Clip (Item 7) will not be used at that location. See **Fig. 2** for the factory welded nut.

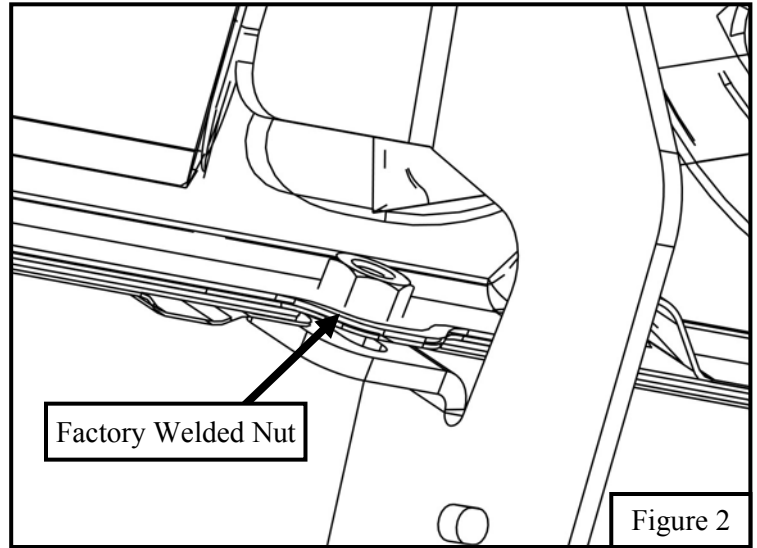
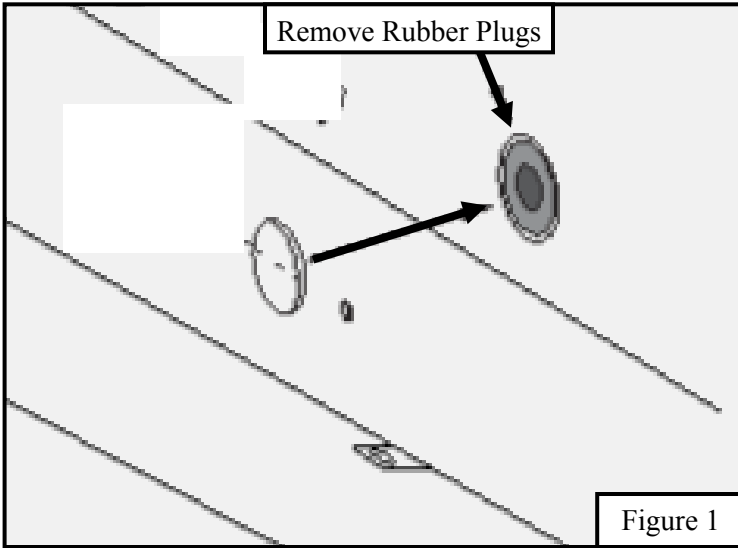

3. Insert (1) M8 U-Nut Clip (Item 7) into the hole where the rubber plug was removed. Clip (1) M8 U-Nut Clip onto pinch weld if no factory welded nut is present. Locate (1) Mounting Bracket A (Item 2) and loosely secure it to the rocker panel using the provided hardware: (2) M8 hex head bolt, (2) M8 flat washer, and (2) M8 lock washer. See **Figure 3**.
4. Repeat **Step 3** for every other bracket mounting location except for the front passenger side mounting location.
5. Locate (1) Mounting Bracket B (Item 11) and go to the front passenger side mounting location. Loosely secure Mounting Bracket B to the rocker panel using (2) M8 hex head bolt, (2) M8 flat washer, (2) M8 lock washer, and (2) M8 U-Nut Clip. Note: For installation on diesel equipped vehicles follow diesel exhaust fluid tank removal instructions on page 4.
5. Locate (1) Plastic Bracket Cover (Item 3) and loosely secure it to the (6) brackets using the provided hardware: (2) M6 hex head bolt, (4) M6 flat washer, and (2) M6 nylon lock nut. Repeat for every bracket. See **Figure 4**.
6. Loosely install the Step Bar Assembly (Item 1) to the previously install mounting brackets with the supplied M8 hardware. See **Figure 5**.
7. Align and adjust the step bars and brackets as needed, then fully tighten all hardware: M8 to 20 ft-lbs, M10 30 ft-lbs, and M6 to 10 ft-lbs.

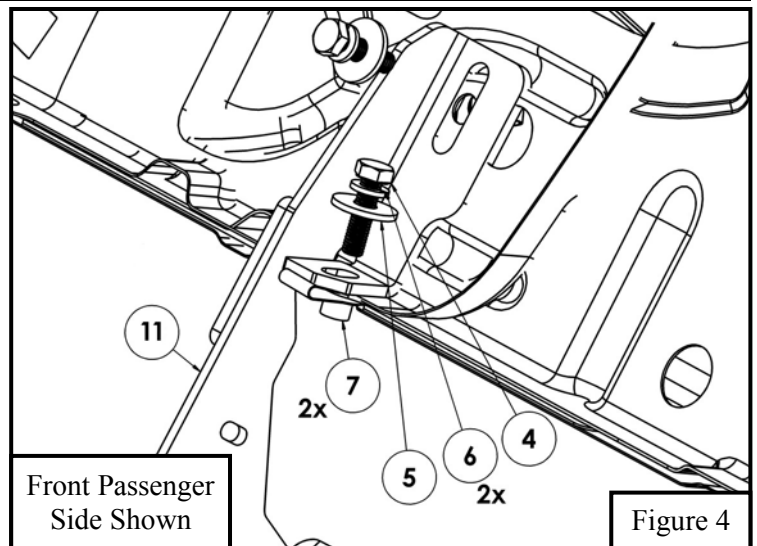
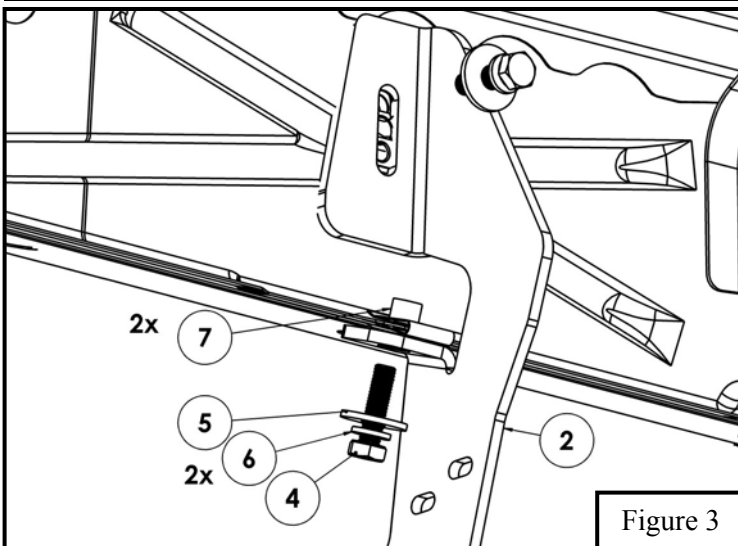

Front Passenger Side Shown

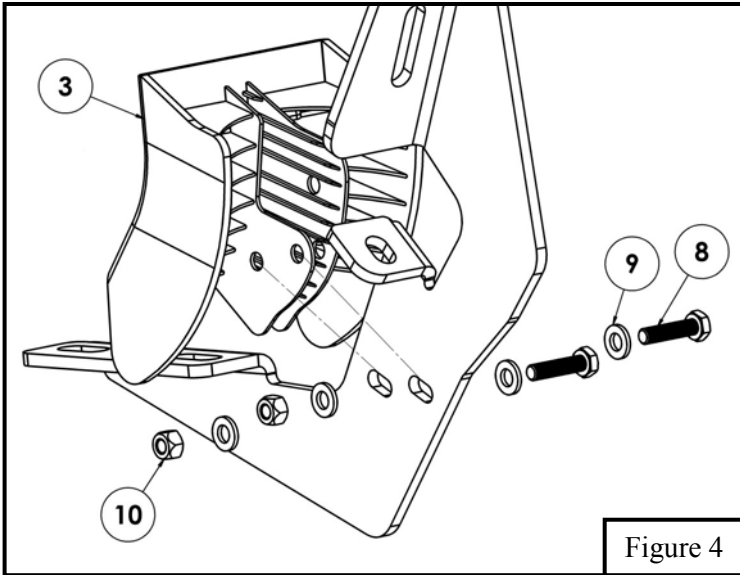

Figure 4

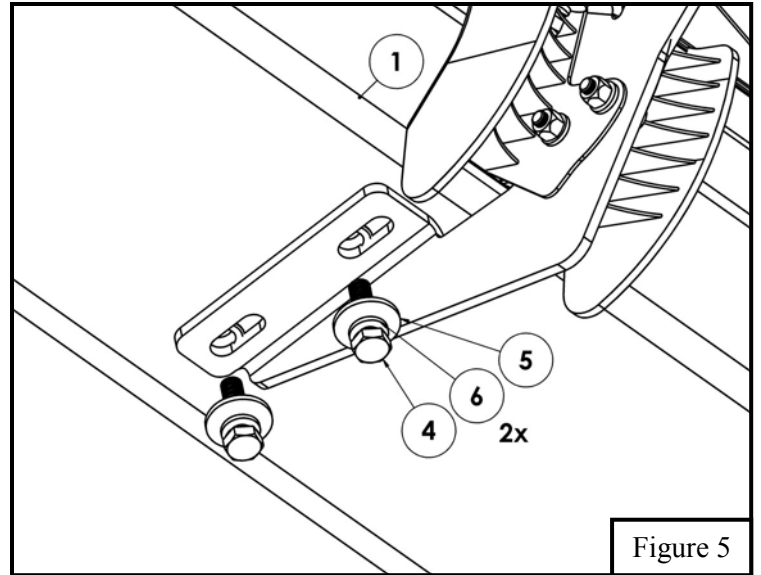
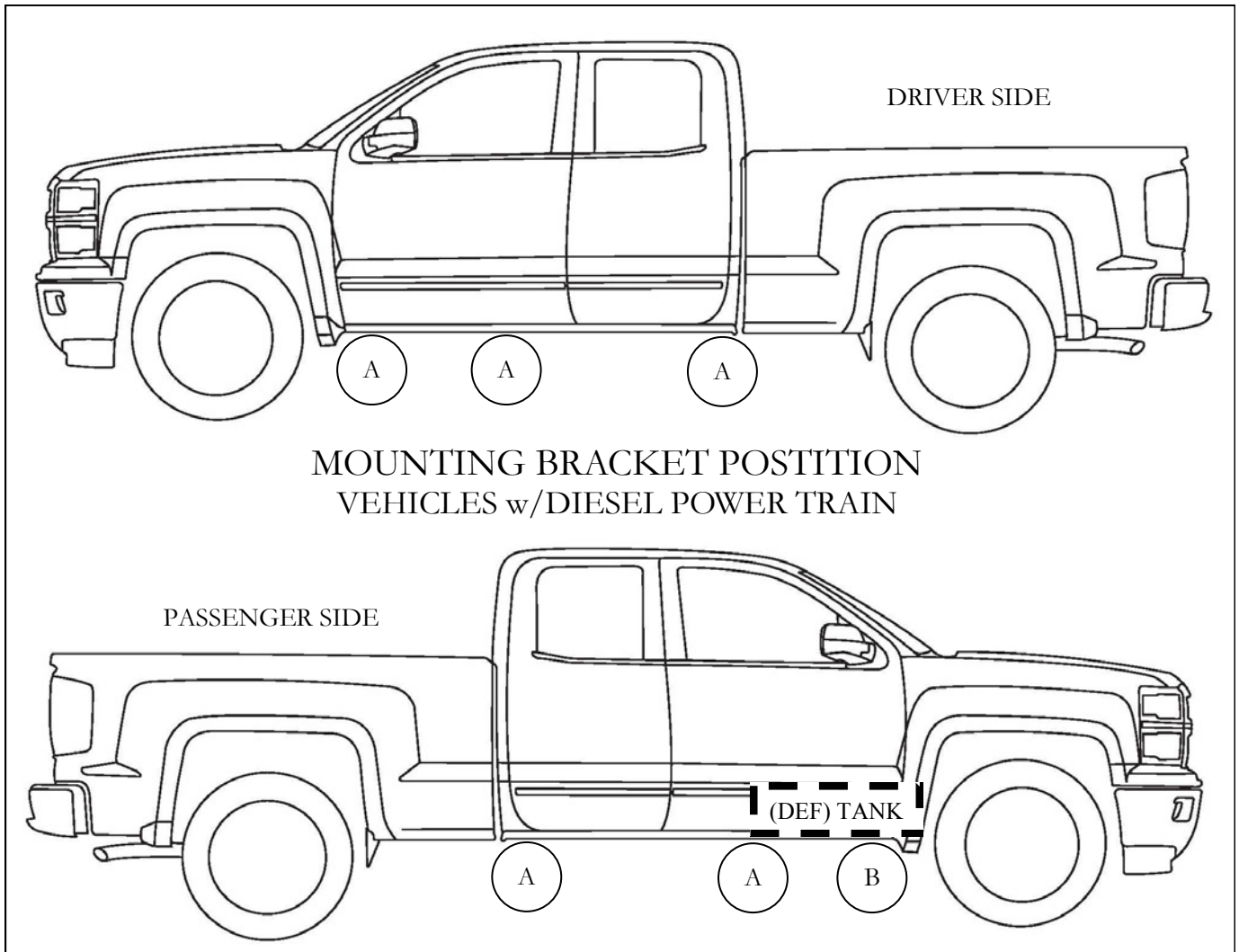

Figure 5

NOTE: For installation on diesel equipped vehicles. Follow the instructions on the following page for the diesel exhaust fluid (DEF) tank removal. This is located adjacent to the passenger side front rocker panel. This is necessary for the installation of the front mounting brackets for the passenger side.



# DIESEL EXHAUST FLUID TANK REMOVAL INSTRUCTIONS

w/Diesel Power Train Only

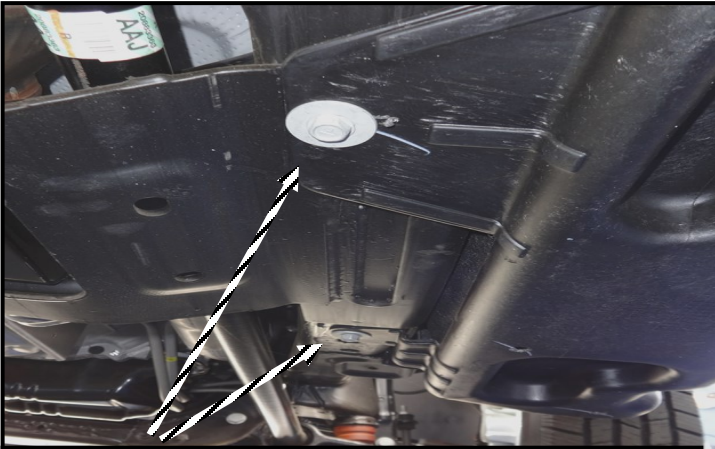

Remove the three bolts that hold the plastic cover by using a ratchet with 13mm socket.

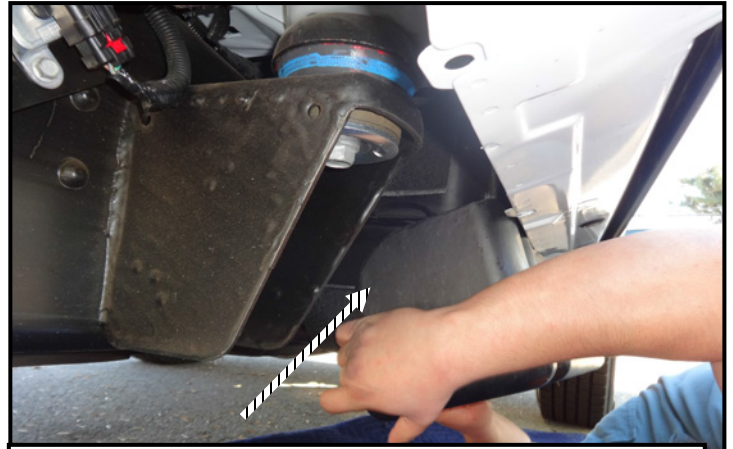

Remove the plastic cover by pulling it toward the side of the truck.

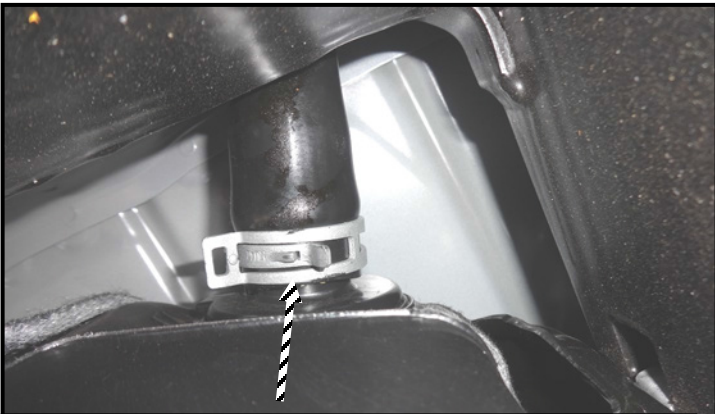

Use a set of pliers to loosen the hose clamp that is under the tank near the front of the truck that holds the filler hose. Carefully remove the filler hose from the tank.



Using a ratchet with a long extension and a 13mm socket to loosen and remove the bolts of the tank support straps. Use an assistant to help hold the tank.

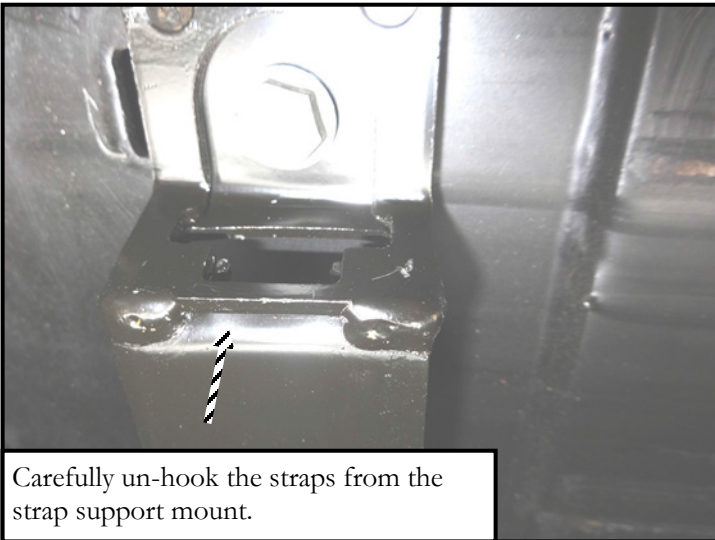

Carefully un-hook the straps from the strap support mount.

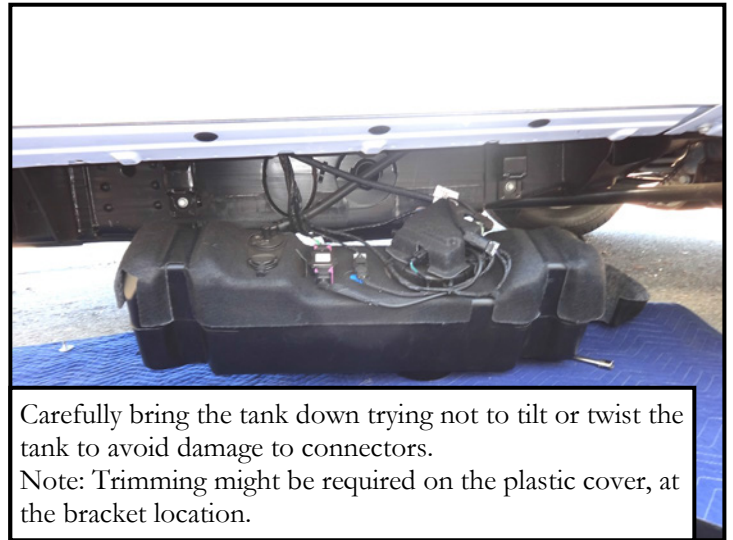

Carefully bring the tank down trying not to tilt or twist the tank to avoid damage to connectors. Note: Trimming might be required on the plastic cover, at the bracket location.

## INSTALLATION COMPLETED



### Care Instructions

- REGULAR WAXING IS RECOMMENDED. DO NOT USE ANY TYPE OF POLISH OR WAX THAT MAY CONTAIN ABRASIVES.
- STAINLESS STEEL PRODUCTS CAN BE CLEANED WITH MILD SOAP AND WATER. STAINLESS STEEL POLISH SHOULD BE USED TO POLISH SMALL SCRATCHES.
- GLOSS BLACK FINISHES SHOULD BE CLEANED WITH MILD SOAP AND WATER.

# Westin

SIGNATURE OF QUALITY

AUTOMOTIVE PRODUCTS, INC.



## WARNING



Failure to follow these instructions could lead to death, personal injury, and / or property damage.

### FASTENERS:

All Westin supplied fasteners must be utilized and installed in accordance with the installation instructions and apply torque to the specifications as defined. **DOUBLE CHECK ALL FASTENERS BEFORE INITIAL USE, AND PERIODICALLY IN THE FUTURE TO ENSURE PROPER FUNCTION AND SAFETY.**

### DRILLING:

Most Westin products do not require drilling for installation. If drilling is defined as required, use caution when drilling a vehicle. **FAILURE TO REVIEW AN AREA TO BE DRILLED MAY RESULT IN PERSONAL INJURY AND/OR INJURY TO OTHERS AS WELL AS VEHICLE DAMAGE.**

### EYE PROTECTION:

**ALWAYS WEAR SAFETY GLASSES OR GOGGLES DURING THE INSTALLATION PROCESS TO AVOID PERSONAL INJURY.**

### MAXIMUM TOWING/CARRYING CAPACITY:

The Westin Receiver Hitches will have a visible tow rating label affixed directly on the product. User should never exceed the vehicle manufacturers maximum tow and weight rating regardless of the capacity of the hitch. **FAILURE TO FOLLOW THESE GUIDELINES WILL VOID THE WESTIN WARRANTY AND MAY RESULT IN PERSONAL INJURY AND/OR INJURY TO OTHERS AS WELL AS VEHICLE DAMAGE.**

Feel the difference with Westin.

Check out the collection of side steps and nerf bars we offer.