



AUTOMOTIVE PRODUCTS,

# INSTALLATION INSTRUCTIONS

## R5 STEP BOARD

### APPLICATION:

2014-2017 Toyota 4Runner SR5  
 2010-2017 Toyota 4Runner Trail Edition  
 2010-2017 Toyota 4Runner Limited  
 2010-2013 Toyota 4Runner (Excl. Trail Edition, P#: 28-51200/05)

### PART NUMBER:

28-51190, 28-51195, 28-51200, 28-51205

ITEM	QUANTITY	DESCRIPTION	TOOLS NEEDED
1,2	2	STEP BOARDS, DRIVER (1) AND PASSENGER (2)	10MM SOCKET
3,4	2	FRONT MOUNT BRACKET, DRIVER (3) AND PASSENGER (4)	10MM WRENCH
5,6	2	REAR MOUNT BRACKET, DRIVER (5) AND PASSENGER (6)	13MM SOCKET
7	4	PLASTIC BRACKET COVER	RATCHET
8	4	ADAPTER PLATE (ONLY FOR 28-51190 & 28-51200)	TORQUE WRENCH
9	8	M8 SQUARE HEAD BOLT (BLACK ZINC) (ONLY FOR 28-51195 & 28-51205)	
10	12	M8 HEX HEAD CAP SCREW (BLACK ZINC) SEMS HARDWARE	
11	12	M8 SPLIT LOCK WASHER (BLACK ZINC) SEMS HARDWARE	
12	12	M8 FLAT WASHER (BLACK ZINC) SEMS HARDWARE	
13	12	M8 SPLIT LOCK WASHER (BLACK ZINC)	
14	12	M8 FLAT WASHER (BLACK ZINC)	
15	12	M8 HEX NUT (BLACK ZINC)	
16	12	M6 HEX HEAD CAP SCREW (YELLOW ZINC)	
17	24	M6 FLAT WASHER (YELLOW ZINC)	
18	12	M6 NYLOCK NUT (YELLOW ZINC)	

**ANTI-SEIZE LUBRICANT MUST BE USED ON ALL STAINLESS STEEL FASTENERS TO PREVENT THREAD DAMAGE AND GALLING**

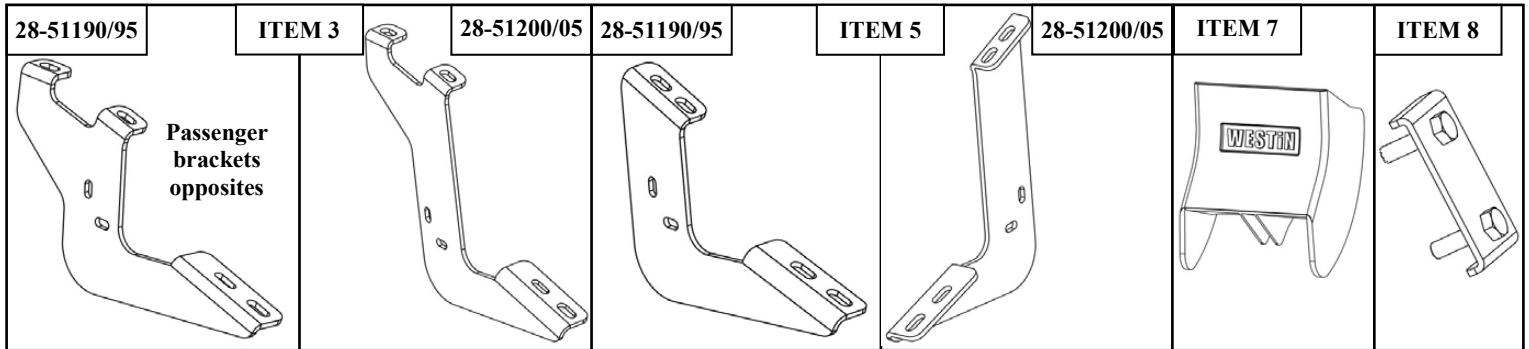

### PROCEDURE

- Remove contents from box, verify if all parts listed are present and free from damage. Carefully read and understand all instructions before attempting installation.  
**Failure to identify damage before installation could lead to a rejection of any claim.**
- Starting on the driver's side front. Locate front mount location on the rocker panel with two rocker panel bracket bolts. Remove factory bolts (will not be used). Locate (1) front mount bracket (Item 3/4) and loosely install using the provided SEMS M8 hardware (Items 10-12). See **Figure 1 and 2**.



Thank you for choosing Westin products.

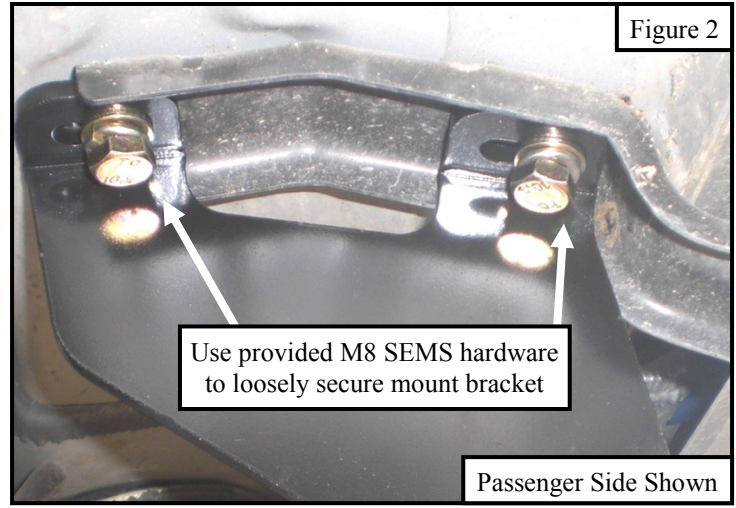
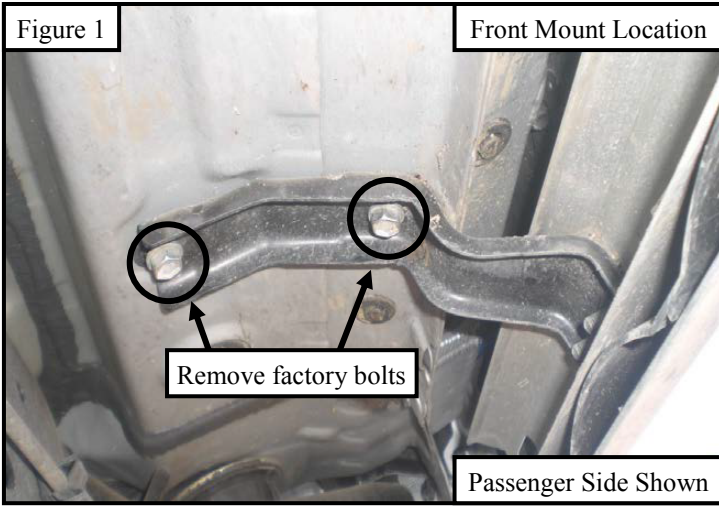

3. Locate the driver's side rear mounting location on the rocker panel with two rocker panel bracket bolts. Remove factory bolts (will not be used). Locate (1) rear mount bracket (Item 5/6) and loosely install using the provided SEMS M8 hardware (Items 10-12). See **Figure 3 and 4**.
4. Repeat **Steps 2 - 3** for passenger side.

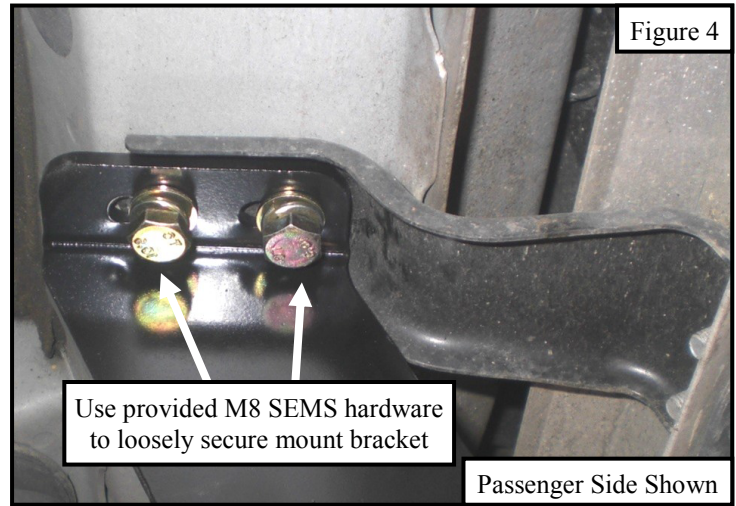
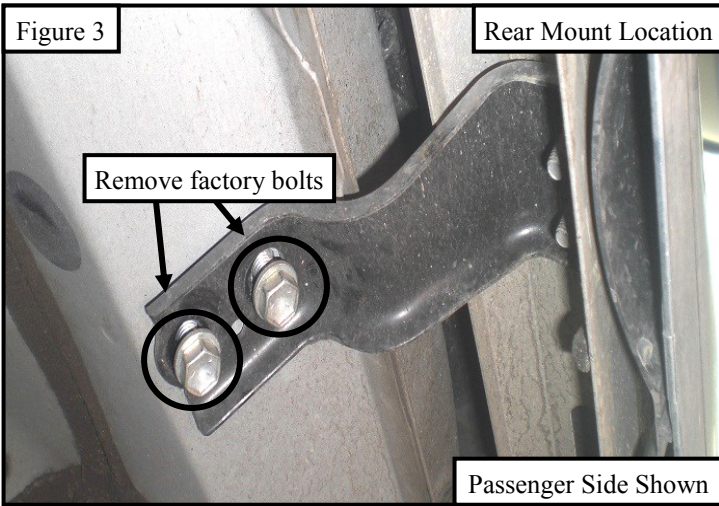

5. Locate (1) plastic bracket cover (Item 7) and loosely secure it to the (4) brackets using the provided hardware: (2) M6 hex head cap screws, (4) M6 flat washers, and (2) M6 nylock nuts. Repeat for every bracket. See **Figure 5**.

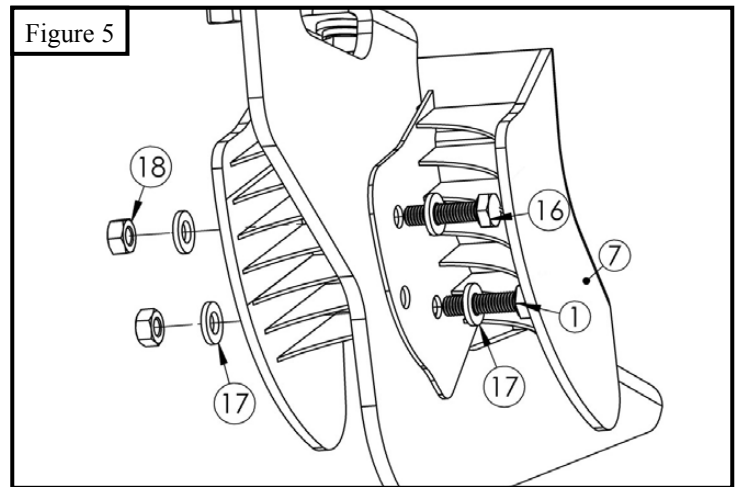
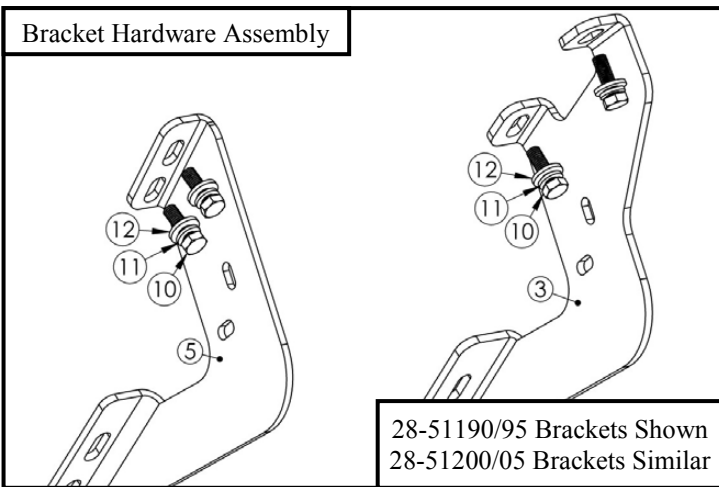



6. **For Part Numbers 28-51195 / 28-51205:** Locate (1) driver side step board (Item 1) and (4) M8 square head bolts (Item 9). Slide the M8 square head bolts through the slots underneath the step board and align with the previously installed mount brackets. Repeat for passenger side. See **Figure 6**.
7. **For Part Numbers 28-51190 / 28-51200:** Locate (1) driver side step board (Item 1) and (2) adapter plates (Item 8). Insert the adapter plates onto the step board and align with the previously installed mount brackets. Repeat for passenger side. (**Figure 7**)

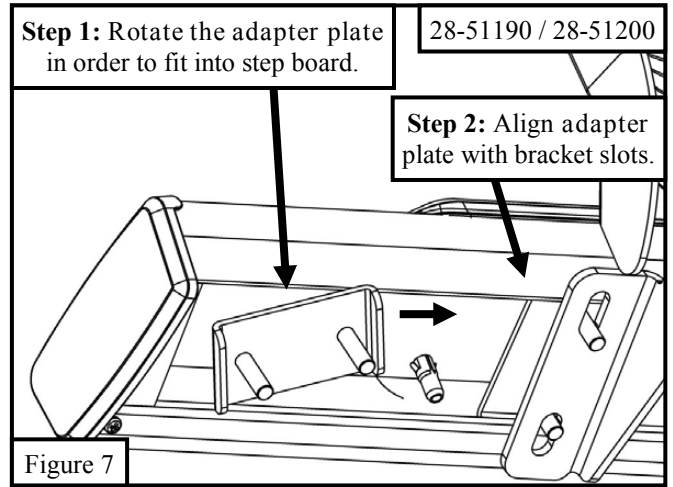
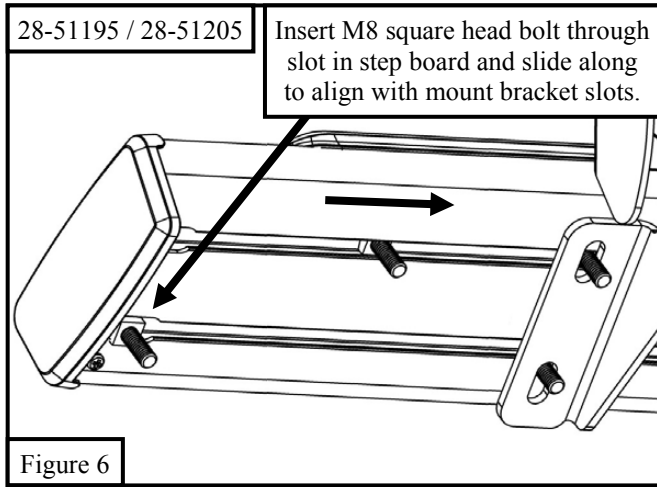

8. Loosely secure the step board onto each mount bracket using (2) M8 hex nuts, (2) M8 split lock washers, and (2) M8 flat washers (Items 13-15). See **Figure 8**.
9. Adjust and align as necessary the mount brackets, step boards, and bracket covers and then tighten M8 hardware to 15-17 ft-lbs and M6 to 5-7 ft-lbs.

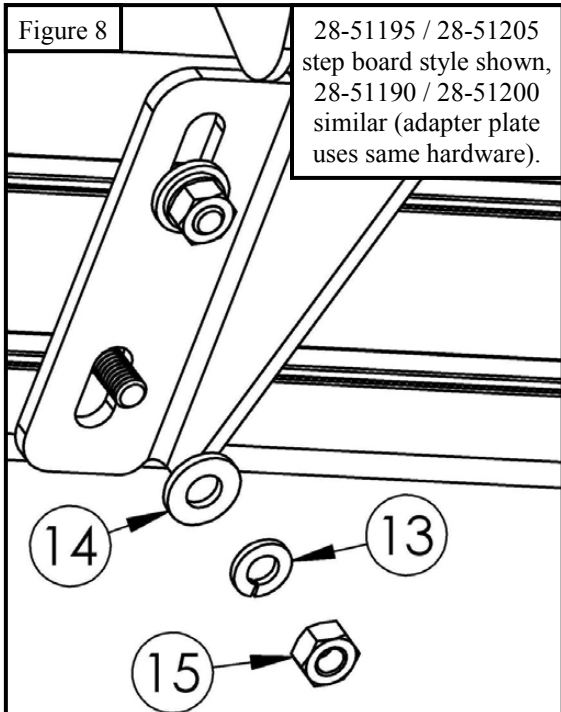

#### CARE INSTRUCTIONS

- REGULAR WAXING IS RECOMMENDED. DO NOT USE ANY TYPE OF POLISH OR WAX THAT MAY CONTAIN ABRASIVES.
- STAINLESS STEEL PRODUCTS CAN BE CLEANED WITH MILD SOAP AND WATER. STAINLESS STEEL POLISH SHOULD BE USED TO POLISH SMALL SCRATCHES.
- GLOSS BLACK FINISHES SHOULD BE CLEANED WITH MILD SOAP AND WATER.



SIGNATURE OF QUALITY

AUTOMOTIVE PRODUCTS, INC.



## WARNING



Failure to follow these instructions could lead to death, personal injury, and / or property damage.

### FASTENERS:

All Westin supplied fasteners must be utilized and installed in accordance with the installation instructions and apply torque to the specifications as defined. **DOUBLE CHECK ALL FASTENERS BEFORE INITIAL USE, AND PERIODICALLY IN THE FUTURE TO ENSURE PROPER FUNCTION AND SAFETY.**

### DRILLING:

Most Westin products do not require drilling for installation. If drilling is defined as required, use caution when drilling a vehicle. **FAILURE TO REVIEW AN AREA TO BE DRILLED MAY RESULT IN PERSONAL INJURY AND/OR INJURY TO OTHERS AS WELL AS VEHICLE DAMAGE.**

### EYE PROTECTION:

**ALWAYS WEAR SAFETY GLASSES OR GOGGLES DURING THE INSTALLATION PROCESS TO AVOID PERSONAL INJURY.**

### MAXIMUM TOWING/CARRYING CAPACITY:

The Westin Receiver Hitches will have a visible tow rating label affixed directly on the product. User should never exceed the vehicle manufacturers maximum tow and weight rating regardless of the capacity of the hitch. **FAILURE TO FOLLOW THESE GUIDELINES WILL VOID THE WESTIN WARRANTY AND MAY RESULT IN PERSONAL INJURY AND/OR INJURY TO OTHERS AS WELL AS VEHICLE DAMAGE.**

[Learn more about other side steps and nerf bars made by Westin on our website.](#)



SIGNATURE OF QUALITY