



AUTOMOTIVE PRODUCTS,

INSTALLATION INSTRUCTIONS

R5 STEP BOARD

APPLICATION:

2009-2017 Dodge Ram 1500 Quad / Crew Cab

2010-2017 Dodge Ram 2500/3500 Crew Cab

PART NUMBER:

28-51040, 28-51045, 28-51050, 28-51055

ITEM	QUANTITY	DESCRIPTION	TOOLS NEEDED
1,2	2	STEP BOARDS, DRIVER (1) AND PASSENGER (2)	10MM SOCKET
3	3	MOUNT BRACKET A	10MM WRENCH
4	2	MOUNT BRACKET B	13MM SOCKET
5	1	MOUNT BRACKET C	13MM WRENCH
6	6	PLATE ADAPTER (ONLY FOR 28-51040 AND 28-51050)	17MM SOCKET
7	6	PLASTIC BRACKET COVER	17MM WRENCH
8	8	M8 HEX RIV-CERT (YELLOW ZINC)	M4 ALLEN WRENCH
9	5	M10 HEX NUT (YELLOW ZINC)	DRILL
10	5	M10 SPLIT LOCK WASHER (YELLOW ZINC)	1/4" DRILL BIT
11	5	M10 FLAT WASHER (YELLOW ZINC)	RATCHET
12	5	M10 BOLT / M8 NUT PLATE (YELLOW ZINC)	TORQUE WRENCH
13	12	M6 HEX HEAD CAP SCREW (YELLOW ZINC)	
14	24	M6 FLAT WASHER (YELLOW ZINC)	
15	12	M6 NYLOCK NUT (YELLOW ZINC)	
16	12	M8 HEX HEAD CAP SCREW (YELLOW ZINC)	
17	12	M8 SPLIT LOCK WASHER (YELLOW ZINC)	
18	12	M8 FLAT WASHER (YELLOW ZINC)	
19	2	M6 BUTTON HEAD CAP SCREW (BLACK ZINC)	
20	2	M6 SERRATED FLANGE NUT (BLACK ZINC)	
21	2	M6 FLAT WASHER (BLACK ZINC)	
22	12	M8 SPLIT LOCK WASHER (BLACK ZINC)	
23	12	M8 FLAT WASHER (BLACK ZINC)	
24	12	M8 HEX NUT (BLACK ZINC)	
25	12	M8 SQUARE HEAD BOLT (BLACK ZINC) (ONLY FOR 28-51045 AND 28-51055)	
26	5	M10 PLASTIC RETAINER SQUARE	

ANTI-SEIZE LUBRICANT MUST BE USED ON ALL STAINLESS STEEL FASTENERS TO PREVENT THREAD DAMAGE AND GALLING

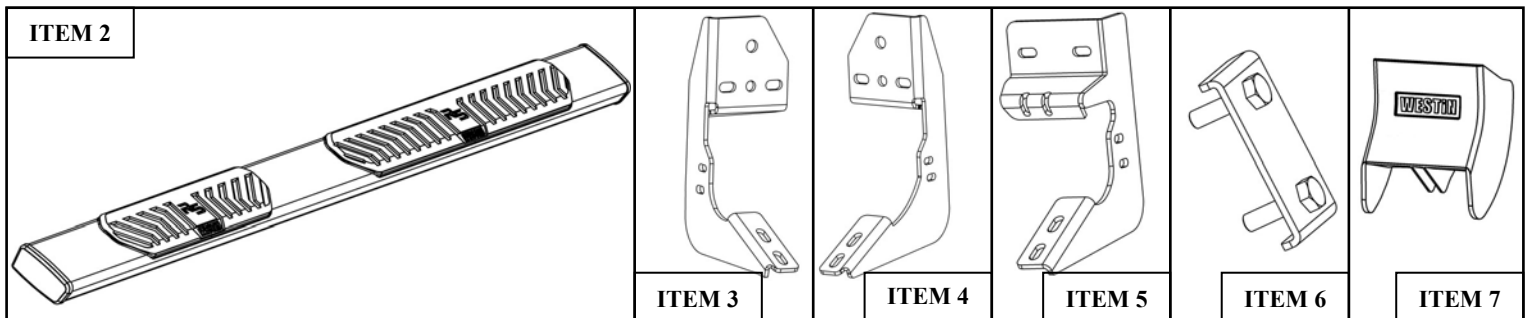

PROCEDURE

1. Remove contents from box, verify if all parts listed are present and free from damage.
Carefully read and understand all instructions before attempting installation.
Failure to identify damage before installation could lead to a rejection of any claim.
2. Check either side of the vehicles rocker panel, locate the factory holes in the rocker panel by removing the tape. Check and verify what type of rocker panel you have. See **Figures 1, 2, 3 & 4**. **Note:** If any of the locations on the factory holes in the rocker panel have factory M8 riv-certs or threaded M8 holes, do not use provided M8 hex riv-certs (Item 8) in that location. Refer to **Figures 1, 2, 3 & 4**.
3. **Starting from the driver side:** If the threaded holes are not present use (2) M8 hex riv-certs (Item 8) and insert them into the hex holes. **Note:** See **Figure 6 & 7** for example on how to tighten M8 riv-certs, it will require to use an M10 bolt with M8 nut plate (Item 12) along with a bracket A or B to perform this task. This procedure will permanently install M8 riv-cert.
4. Proceed to install mounting bracket C (Item 5) onto the rocker panel by using (2) M8 hex cap screw (Item 16), (2) M8 lock washers (Item 17) and (2) M8 flat washers (Item 18). For the pinch weld, attach bracket C by using (2) M6 button head bolts, (2) M6 flat washers and (2) M6 serrated flange nuts (Items 19-21). **Note:** Drilling of two 1/4" holes might be necessary on pinch weld if factory holes are not present. Before drilling place masking tape on drill surface to prevent paint chipping. Drilling will be necessary for the other mounting locations on pinch weld. See **Figures 9 & 10**.
5. On the center and rear mounting locations of drivers side attach (1) M8 riv-cert to rocker panel if not already present. Then proceed to install (1) M10 bolt / M8 nut plate (Item 12) into the rocker panel and thread (1) M10 plastic retainer (Item 26) to the M10 bolt to prevent it from falling into the rocker panel. See **Figure 5**.
6. If the rocker panel has pre-installed M8 riv-certs, the M10/M8 plate will need to be positioned as shown in **Figure 8**.
7. If the rocker panel does not have pre-installed M8 riv-certs then the M10/M8 plate will be used as shown on **Figures 5 & 11**.

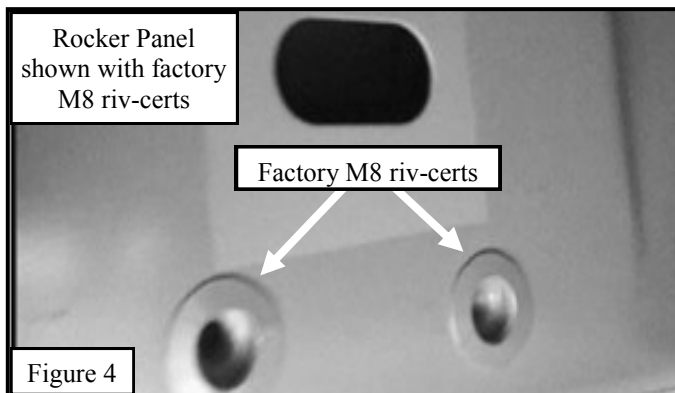
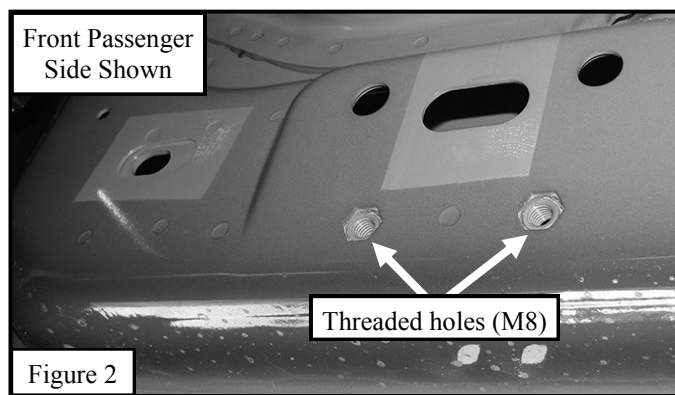
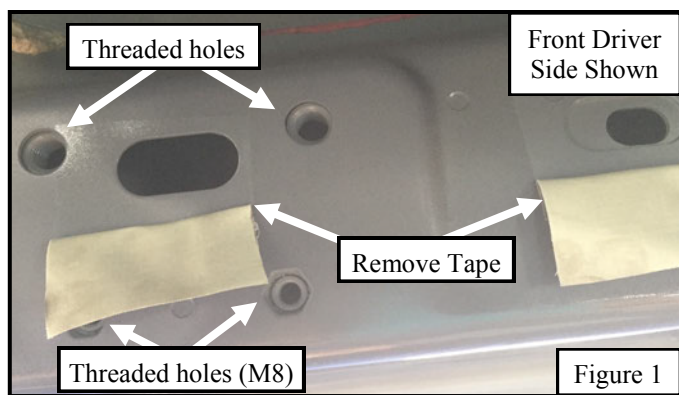

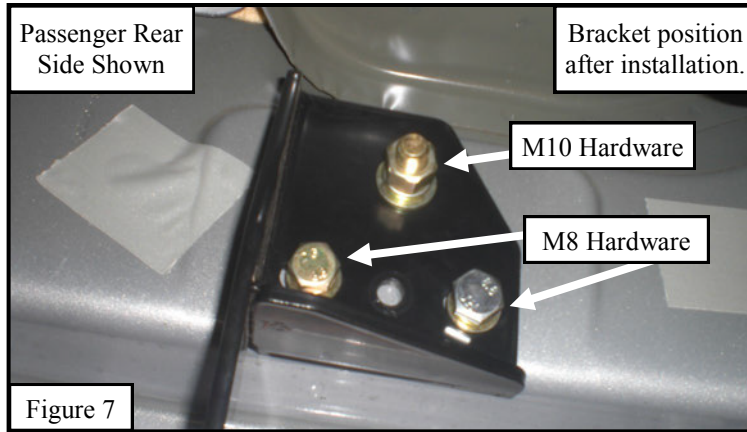
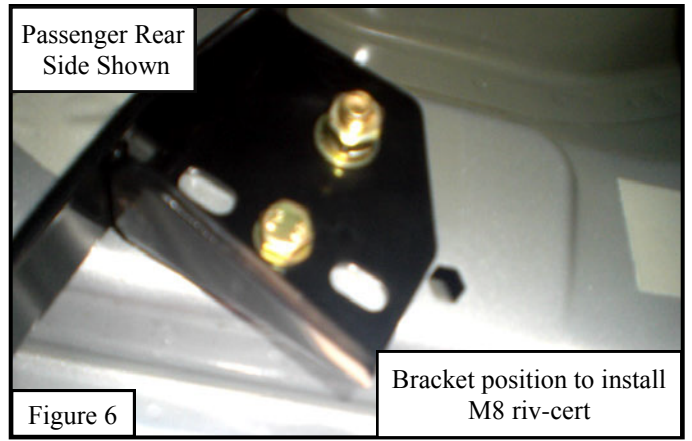
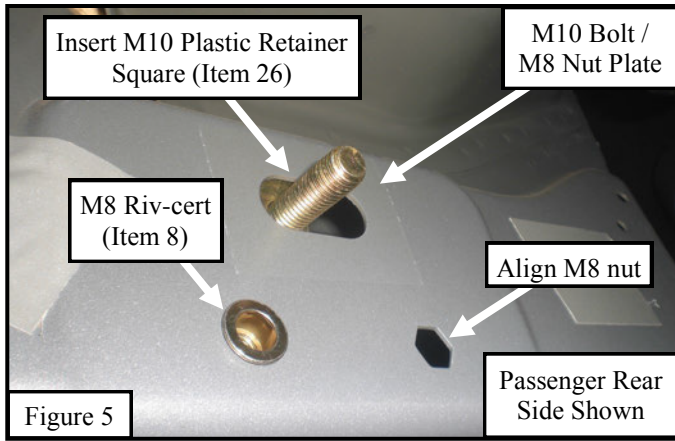

8. Loosely secure mounting bracket A (Item 3) to the rocker panel in the center and rear mounting locations by aligning (Item 12) (as shown on **Figure 5**), using (2) M8 hex bolts (Item 16), (2) M8 lock washers (Item 17), (2) M8 flat washers (Item 18), (1) M10 flat washers (Item 11), (1) M10 lock washers (Item 10) and (1) M10 hex nuts (Item 9). See **Figures 7 & 11**. Refer to **Figure 16** for bracket positioning.
9. **Starting from the passenger side:** Insert (1) M10 bolt / M8 nut plate (Item 12) into the rocker panel and thread (1) M10 plastic retainer (Item 26) to the M10 bolt to prevent it from falling into the rocker panel. See **Figure 5**.
10. If the rocker panel has pre-installed M8 riv-certs, the M10/M8 plate will need to be positioned as shown in **Figure 8**.
11. If the rocker panel does not have pre-installed M8 riv-certs then the M10/M8 plate will be used as shown on **Figures 5 & 11**.
12. Attach mounting bracket A (Item 3) to passenger front and mounting bracket B (Item 4) to passenger center and rear using the same procedure as **Step 8**. Refer to **Figure 17** for bracket positioning.

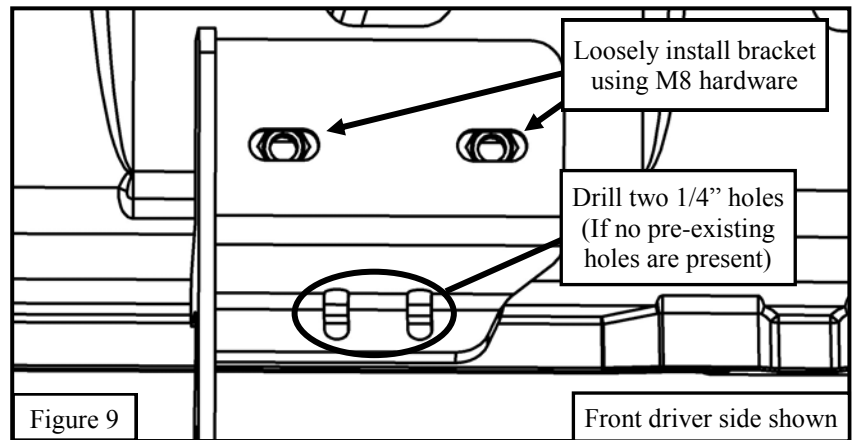
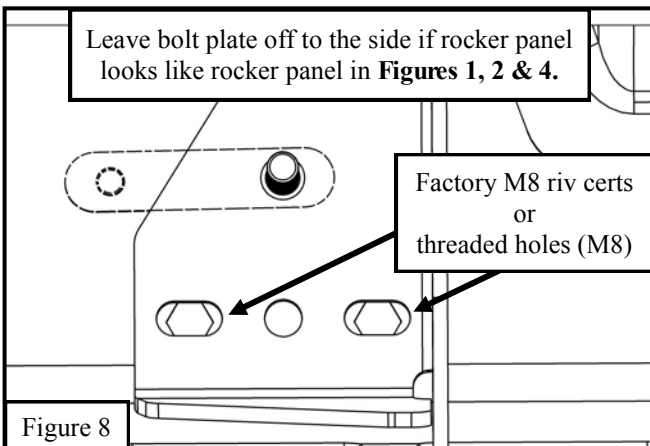

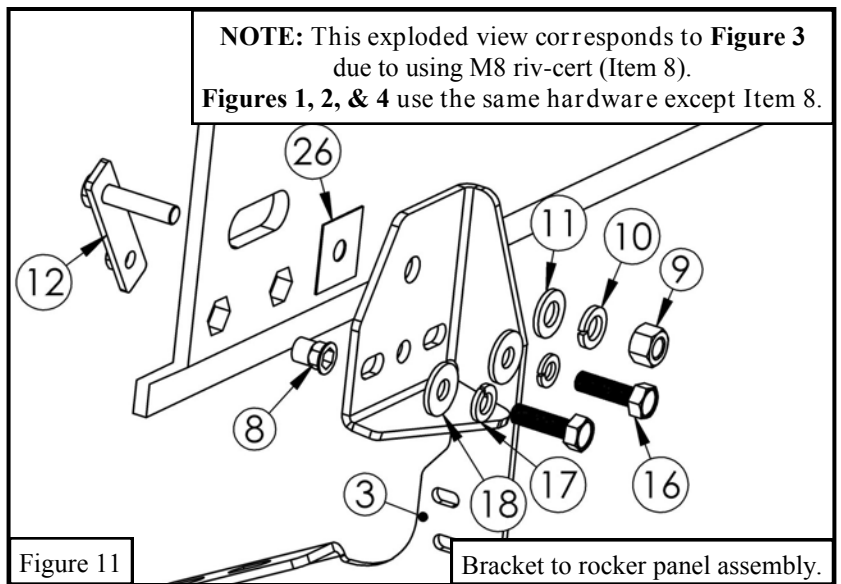
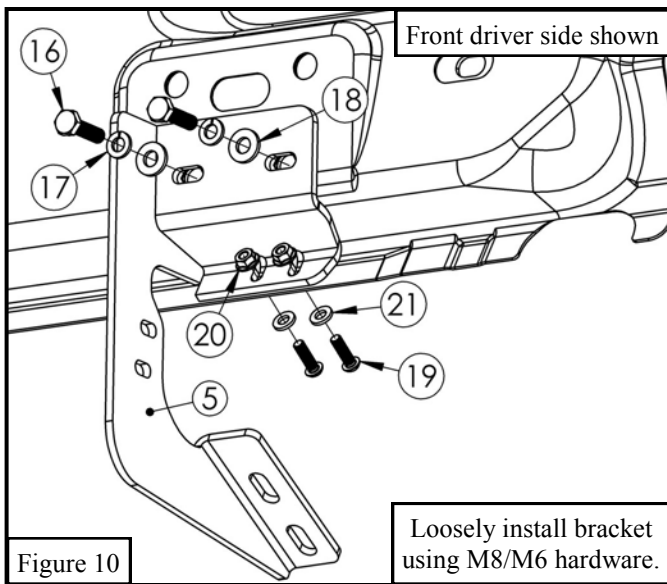

13. Locate (1) plastic bracket cover (Item 7) and loosely secure it to the (6) brackets using the provided hardware: (2) M6 hex head bolts, (4) M6 flat washers, and (2) M6 nylock nuts (Items 13-15). Repeat for every bracket. See **Figure 12**.
14. **For Part Numbers 28-51040 and 28-51050:** Locate (1) driver side step board (Item 1) and (3) adapter plates (Item 6). Insert the adapter plates onto the step board and align with the previously installed mount brackets. Repeat for passenger side. See **Figure 13**.
15. **For Part Numbers 28-51045 and 28-51055:** Locate (1) driver side step board (Item 1) and (6) M8 square head bolts (Item 25). Slide the M8 square head bolts through the slots underneath the step board and align with the previously installed mount brackets. Repeat for passenger side. See **Figure 14**.
16. Loosely secure the step board onto each mount bracket using (2) M8 hex nuts, (2) M8 split lock washers, and (2) M8 flat washers (Items 22 - 24). See **Figure 15**.
17. Adjust and align as necessary the mount brackets, step boards, and bracket covers and then tighten M8 hardware to 15-17 ft-lbs., M10 to 30-35 ft-lbs, and M6 to 5-7 ft-lbs.

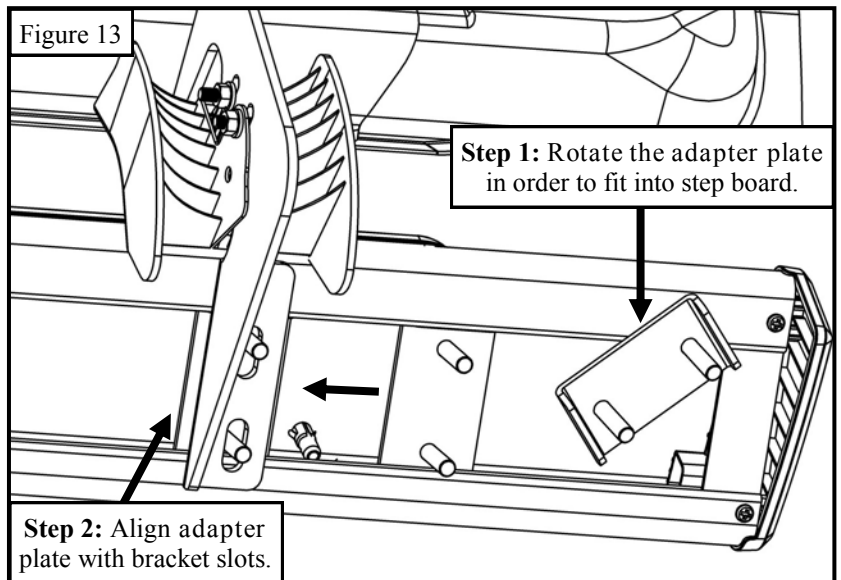
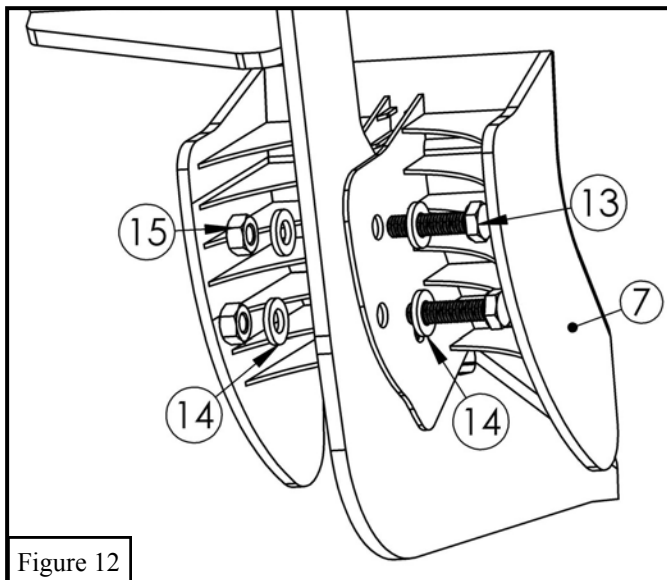

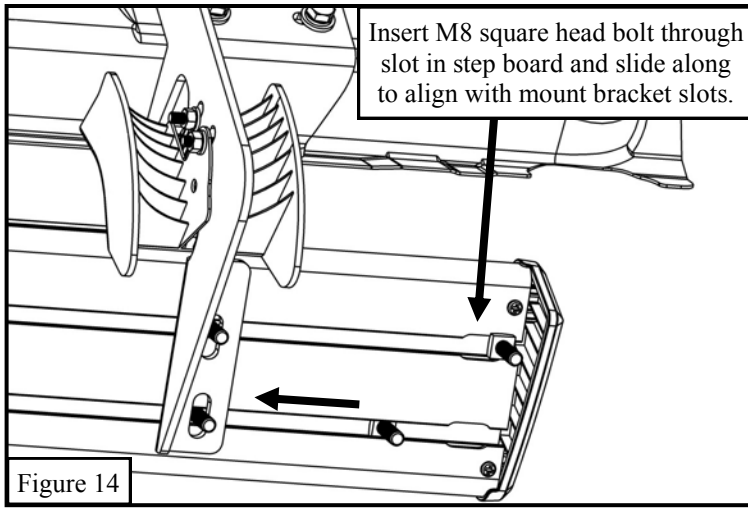

Figure 14

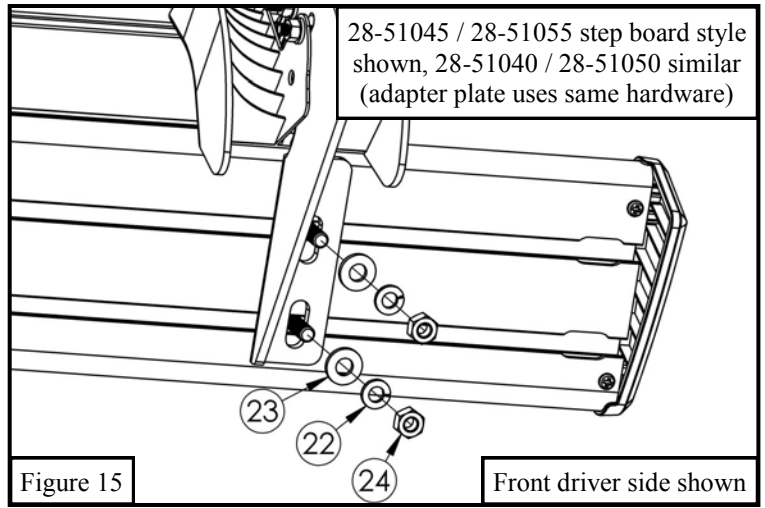
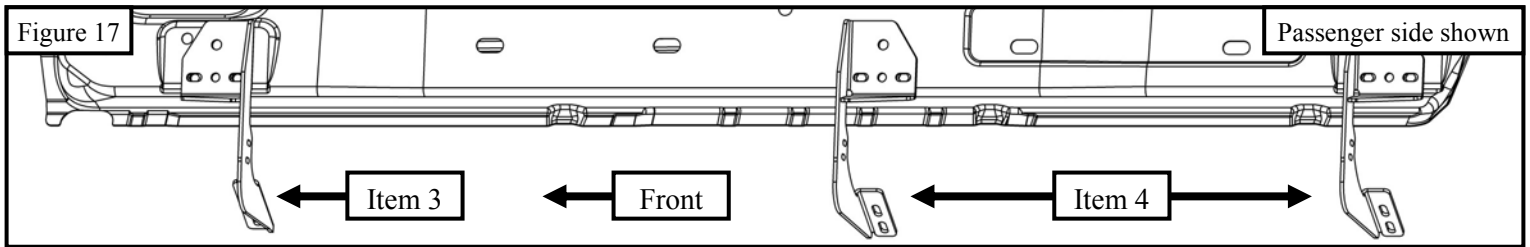
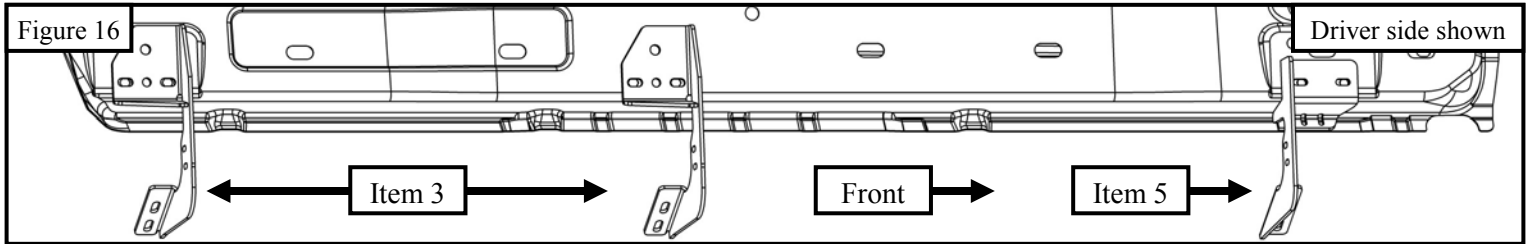

Figure 15

Front driver side shown



CARE INSTRUCTIONS

- REGULAR WAXING IS RECOMMENDED. DO NOT USE ANY TYPE OF POLISH OR WAX THAT MAY CONTAIN ABRASIVES.
- STAINLESS STEEL PRODUCTS CAN BE CLEANED WITH MILD SOAP AND WATER. STAINLESS STEEL POLISH SHOULD BE USED TO POLISH SMALL SCRATCHES.
- GLOSS BLACK FINISHES SHOULD BE CLEANED WITH MILD SOAP AND WATER.

Westin

SIGNATURE OF QUALITY

AUTOMOTIVE PRODUCTS, INC.



WARNING



Failure to follow these instructions could lead to death, personal injury, and / or property damage.

FASTENERS:

All Westin supplied fasteners must be utilized and installed in accordance with the installation instructions and apply torque to the specifications as defined. **DOUBLE CHECK ALL FASTENERS BEFORE INITIAL USE, AND PERIODICALLY IN THE FUTURE TO ENSURE PROPER FUNCTION AND SAFETY.**

DRILLING:

Most Westin products do not require drilling for installation. If drilling is defined as required, use caution when drilling a vehicle. **FAILURE TO REVIEW AN AREA TO BE DRILLED MAY RESULT IN PERSONAL INJURY AND/OR INJURY TO OTHERS AS WELL AS VEHICLE DAMAGE.**

EYE PROTECTION:

ALWAYS WEAR SAFETY GLASSES OR GOGGLES DURING THE INSTALLATION PROCESS TO AVOID PERSONAL INJURY.

MAXIMUM TOWING/CARRYING CAPACITY:

The Westin Receiver Hitches will have a visible tow rating label affixed directly on the product. User should never exceed the vehicle manufacturers maximum tow and weight rating regardless of the capacity of the hitch. **FAILURE TO FOLLOW THESE GUIDELINES WILL VOID THE WESTIN WARRANTY AND MAY RESULT IN PERSONAL INJURY AND/OR INJURY TO OTHERS AS WELL AS VEHICLE DAMAGE.**

[Learn more about other side steps and nerf bars made by Westin on our website.](#)

Westin.
SIGNATURE OF QUALITY