



INSTALLATION INSTRUCTIONS

R5 STEP BOARD

APPLICATION:

2007-2017 Chevrolet Silverado / GMC Sierra Extended / Double / Crew Cab PART NUMBER:

28-51020, 28-51025, 28-51030, 28-51035

AUTOMOTIVE PRODUCTS,

ITEM	QUANTITY	DESCRIPTION	TOOLS NEEDED
1,2	2	STEP BOARDS, DRIVER (1) AND PASSENGER (2)	10MM SOCKET
3	5	MOUNT BRACKET A	13MM SOCKET
4	1	MOUNT BRACKET B	RATCHET
5	6	ADAPTER PLATE (ONLY FOR 28-51020 & 28-51030)	TORQUE WRENCH
6	6	PLASTIC BRACKET COVER	
7	12	M8 EXTRUDED U-NUT (YELLOW ZINC)	
8	12	M8 HEX HEAD CAP SCREW (YELLOW ZINC) SEMS HARDWARE	
9	12	M8 SPLIT LOCK WASHER (YELLOW ZINC) SEMS HARDWARE	
10	12	M8 FLAT WASHER (YELLOW ZINC) SEMS HARDWARE	
11	12	M8 HEX NUT (YELLOW ZINC)	
12	12	M8 FLAT WASHER (YELLOW ZINC)	
13	12	M8 SPLIT LOCK WASHER (YELLOW ZINC)	
14	12	M6 HEX HEAD CAP SCREW (YELLOW ZINC)	
15	24	M6 FLAT WASHER (YELLOW ZINC)	
16	12	M6 NYLOCK NUT (YELLOW ZINC)	
17	12	M8 SQUARE HEAD BOLT (YELLOW ZINC) (ONLY FOR 28-51025 & 28-51035)	

ANTI-SEIZE LUBRICANT MUST BE USED ON ALL STAINLESS STEEL FASTENERS TO PREVENT THREAD DAMAGE AND GALLING

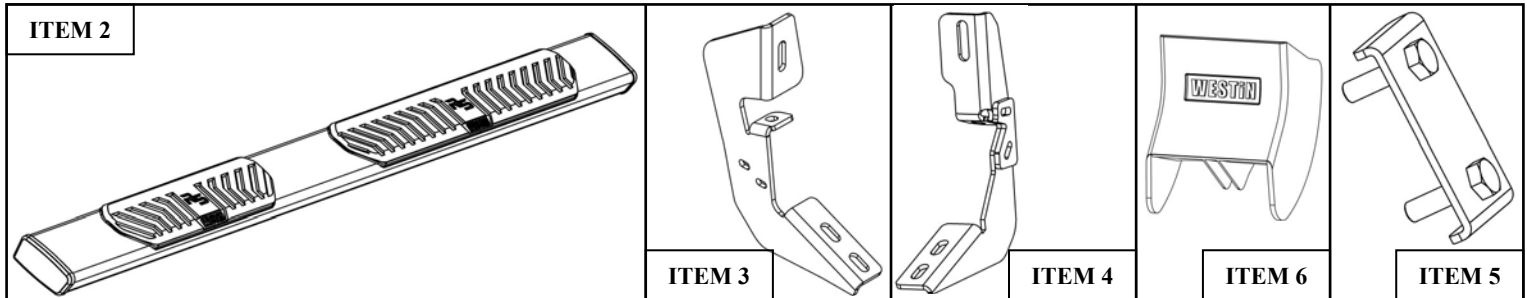

PROCEDURE

1. Remove contents from box, verify if all parts listed are present and free from damage. Carefully read and understand all instructions before attempting installation.
Failure to identify damage before installation could lead to a rejection of any claim.
2. Starting on the driver side, remove the rubber plugs located on the rocker panel at each mounting location. Insert (2) M8 extruded u-nuts on the mount location. See **Figure 1**. **Note:** Some locations may have factory welded nut on mount location so only (1) M8 extruded u-nut will be used. See **Figure 2**.
3. Locate (1) mount bracket A (Item 3) and loosely secure onto vehicle using the provided M12 SEMS hardware. See **Figure 3**. **Note:** Passenger side front mount location will install the same but will use mount bracket B (Item 4) for diesel applications. (**Figure 4**) **Note:** For installation on diesel equipped vehicles follow diesel exhaust fluid tank removal instructions on page 5. **Note:** Refer to **page 3** for the different bracket layouts for gas or diesel vehicles.



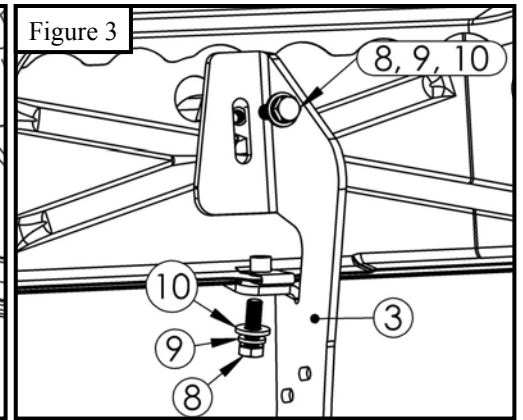
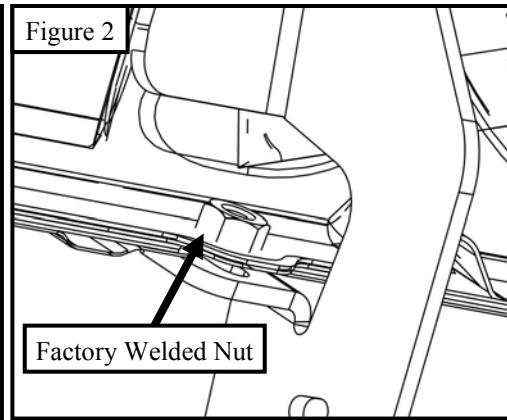
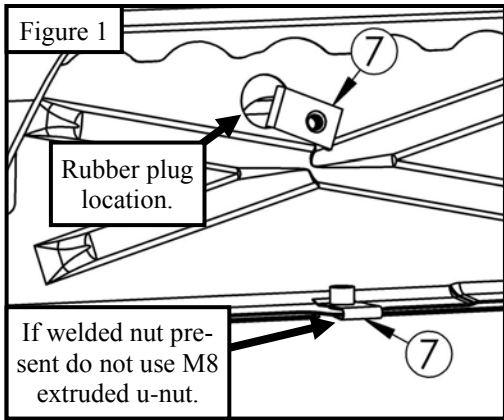

4. Locate (1) plastic bracket cover (Item 6) and loosely secure onto mount bracket using the provided M6 hardware (Items 14 - 16). See **Figure 5**.
5. Repeat **Steps 2 - 4** for every mount location. **Note:** Front passenger side will use mount bracket B instead of mount bracket A.
6. **For Part Numbers 28-51025 and 28-51035:** Locate (1) driver side step board (Item 1) and (6) M8 square head bolts (Item 17). Slide the M8 square head bolts through the slots underneath the step board and align with the previously installed mount brackets. Repeat for passenger side. See **Figure 6**.
7. **For Part Numbers 28-51020 and 28-51030:** Locate (1) driver side step board (Item 1) and (3) adapter plates (Item 5). Insert the adapter plates onto the step board and align with the previously installed mount brackets. Repeat for passenger side. See **Figure 7**.

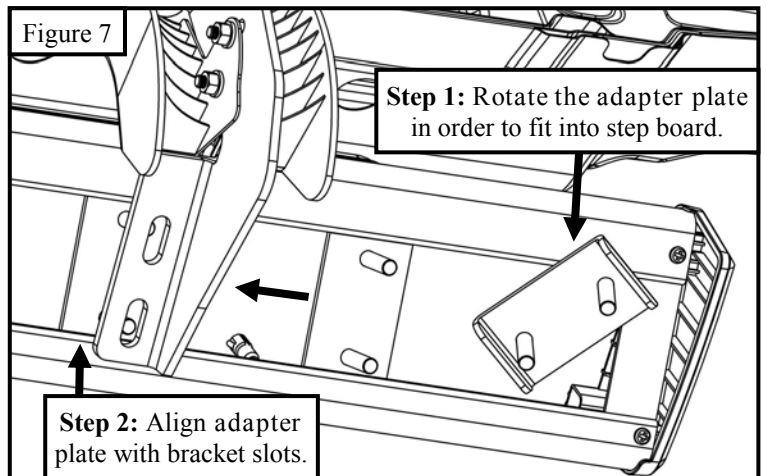
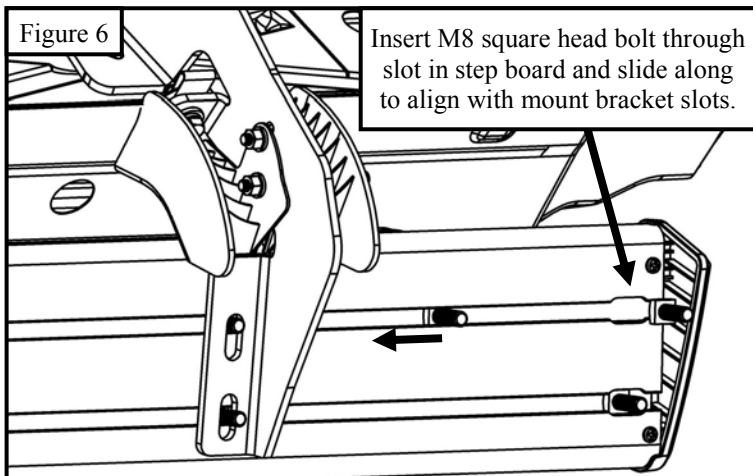
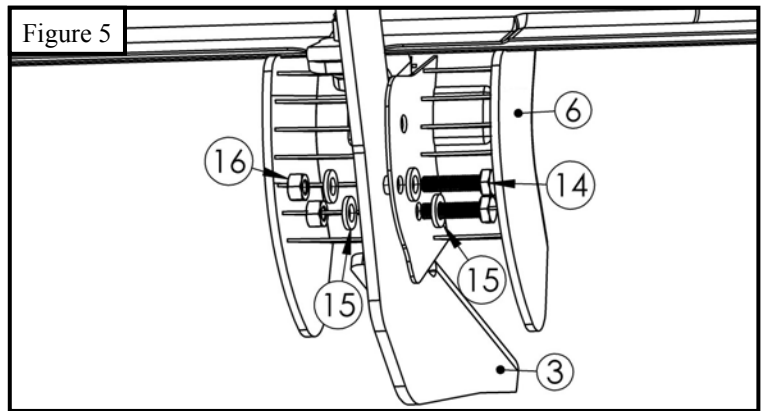
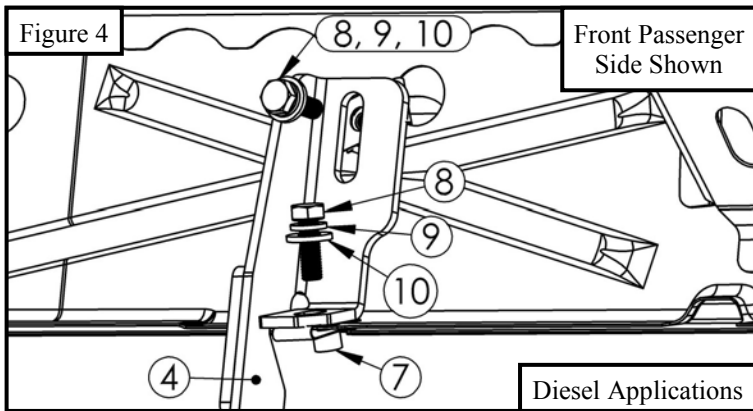

ALL 2011 - 2017 DIESEL SILVERADO / SIERRA: EXTENDED/DOUBLE AND CREW CAB

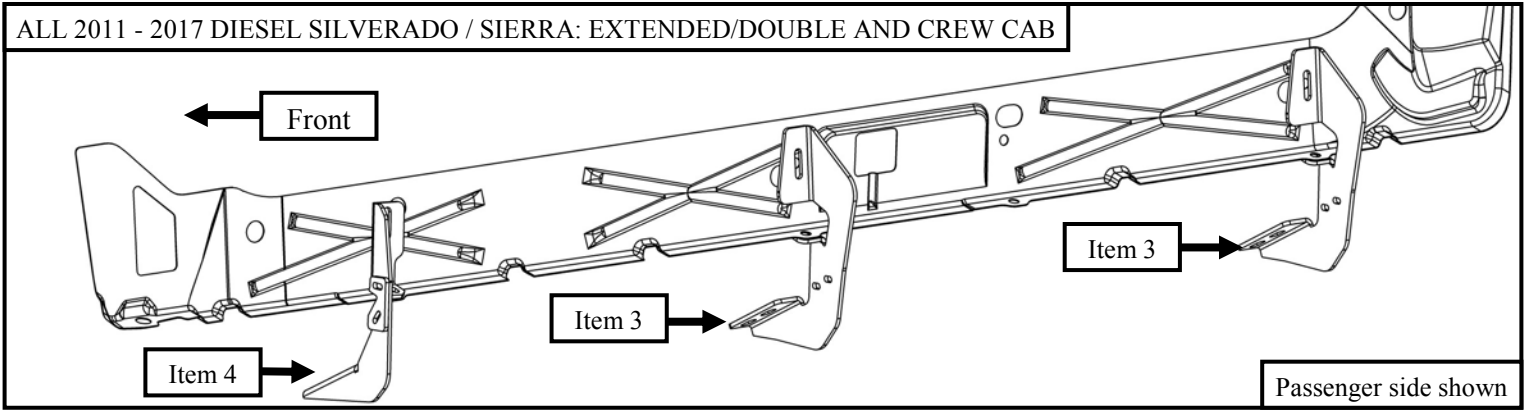

ALL 2011 - 2017 DIESEL SILVERADO / SIERRA: EXTENDED/DOUBLE AND CREW CAB

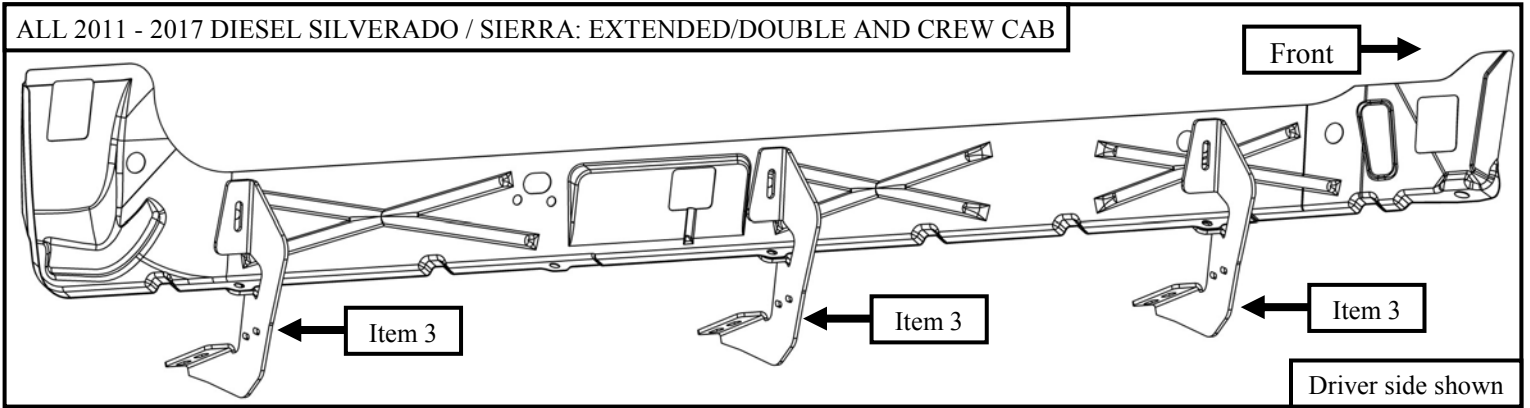

ALL 2007 - 2010 DIESEL & 2007 - 2017 GAS SILVERADO / SIERRA: EXTENDED/DOUBLE AND CREW CAB

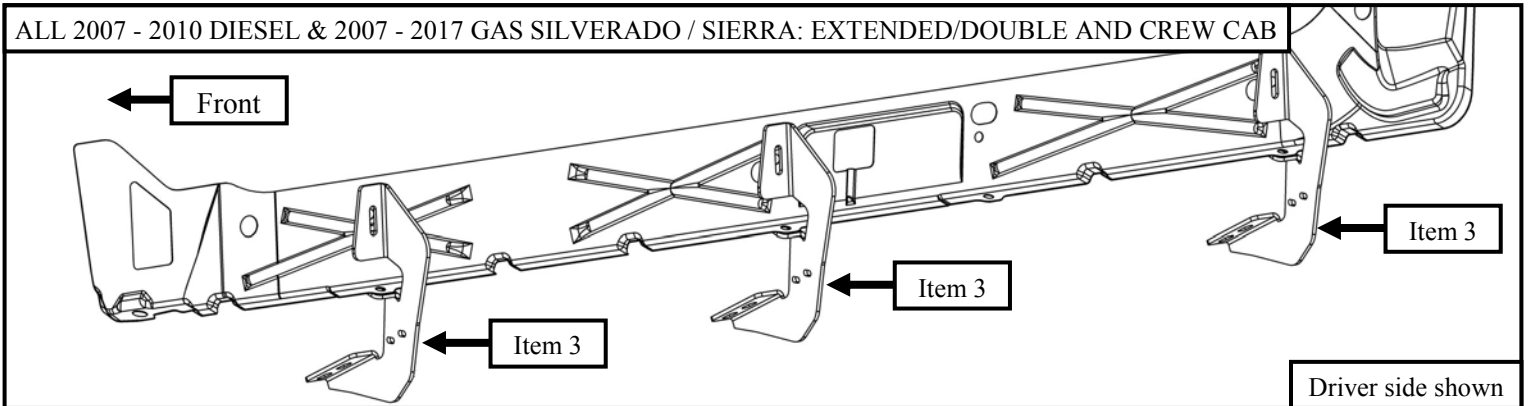

ALL 2007 - 2010 DIESEL & 2007 - 2017 GAS SILVERADO / SIERRA: EXTENDED/DOUBLE AND CREW CAB

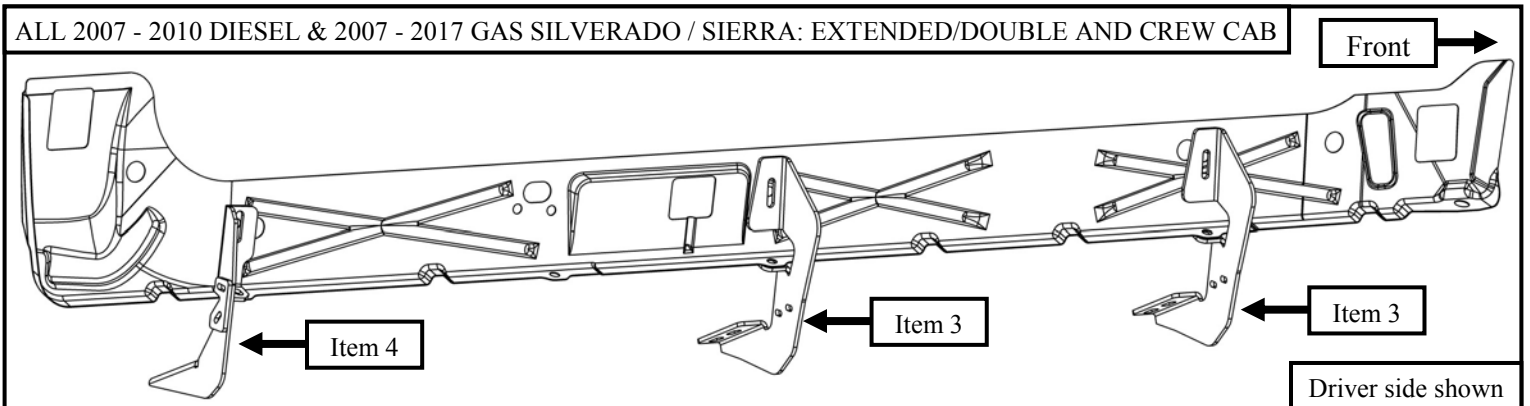

8. Loosely secure the step board onto each mount bracket using (2) M8 hex nuts, (2) M8 split lock washers, and (2) M8 flat washers (Items 11 - 13). See **Figure 8**.
9. Adjust and align as necessary the mount brackets, step boards, and bracket covers and then tighten M8 hardware to 15-17 ft-lbs and M6 to 5-7 ft-lbs.

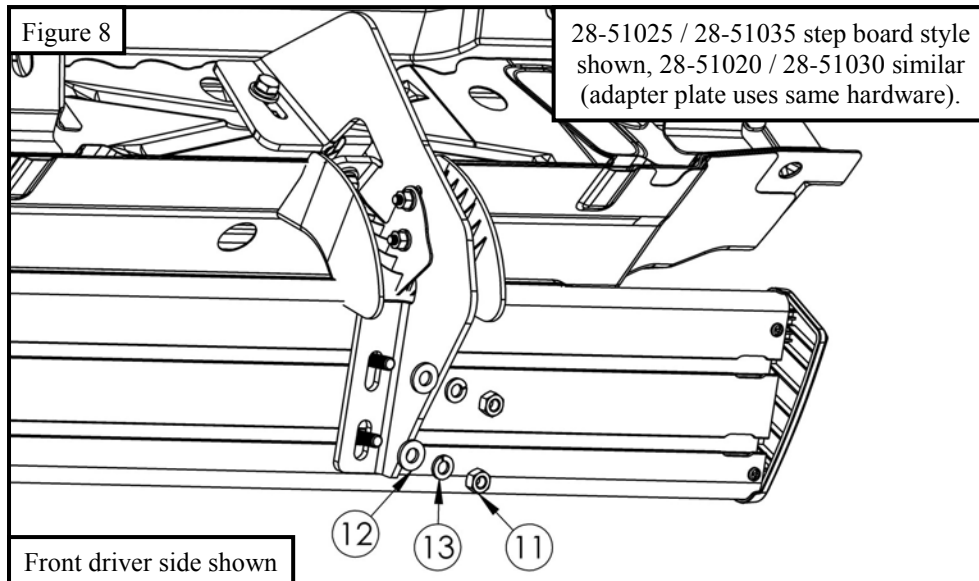

CARE INSTRUCTIONS

- REGULAR WAXING IS RECOMMENDED. DO NOT USE ANY TYPE OF POLISH OR WAX THAT MAY CONTAIN ABRASIVES.
- STAINLESS STEEL PRODUCTS CAN BE CLEANED WITH MILD SOAP AND WATER. STAINLESS STEEL POLISH SHOULD BE USED TO POLISH SMALL SCRATCHES.
- GLOSS BLACK FINISHES SHOULD BE CLEANED WITH MILD SOAP AND WATER.

DIESEL EXHAUST FLUID TANK REMOVAL INSTRUCTIONS

w/Diesel Power Train Only

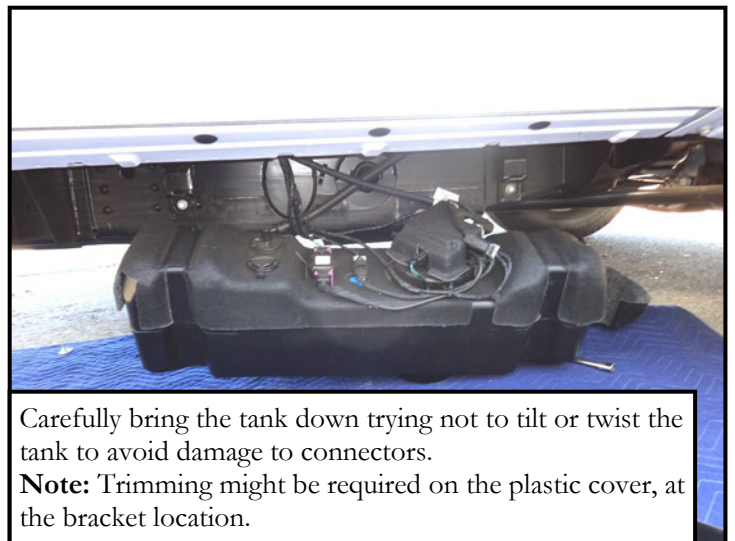
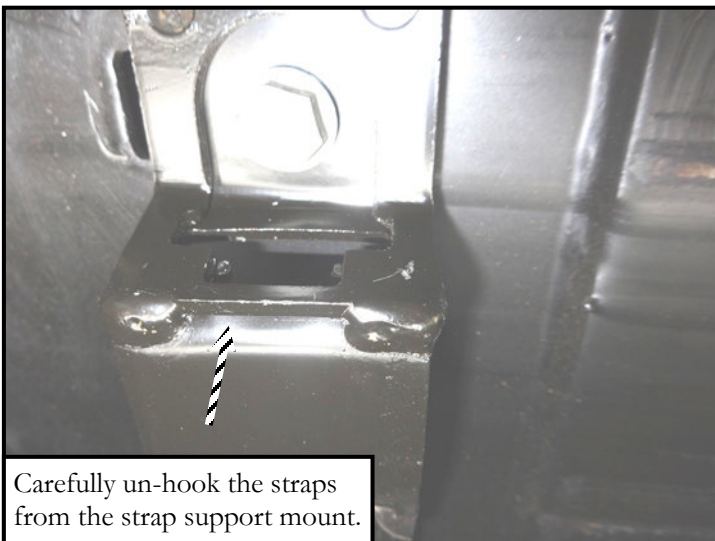
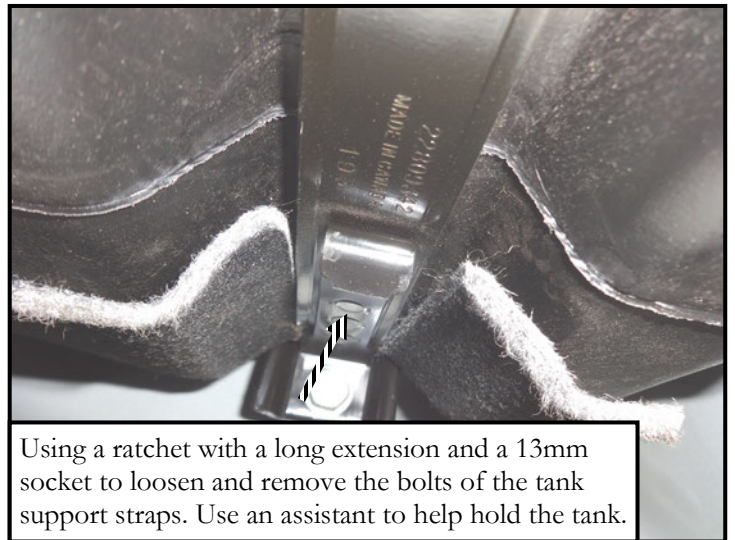
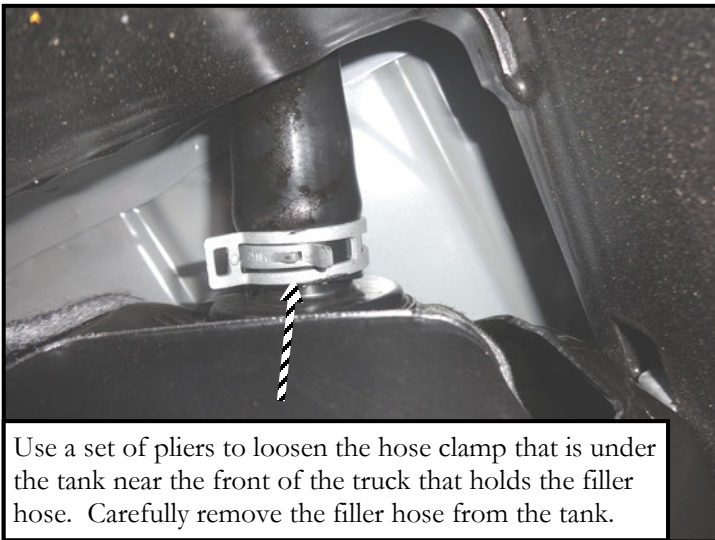
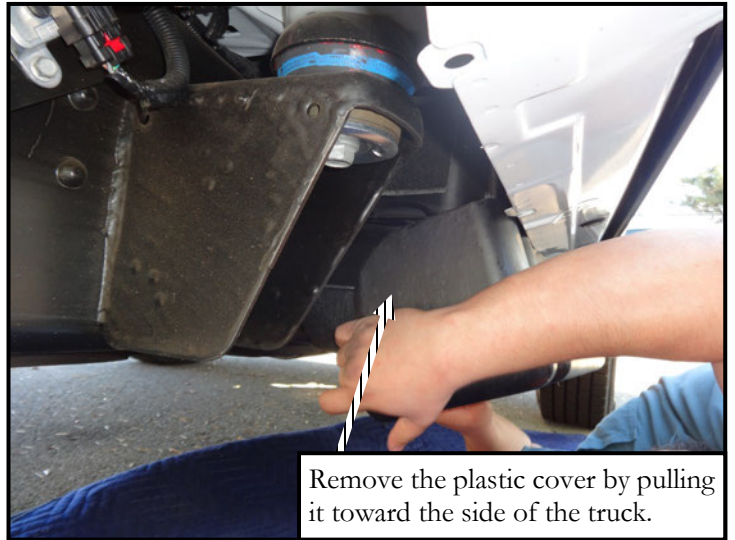
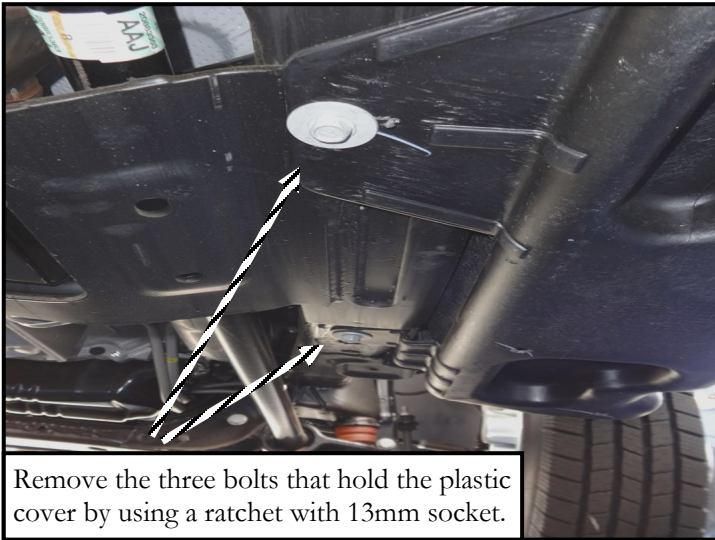

Westin

SIGNATURE OF QUALITY

AUTOMOTIVE PRODUCTS, INC.



WARNING



Failure to follow these instructions could lead to death, personal injury, and / or property damage.

FASTENERS:

All Westin supplied fasteners must be utilized and installed in accordance with the installation instructions and apply torque to the specifications as defined. **DOUBLE CHECK ALL FASTENERS BEFORE INITIAL USE, AND PERIODICALLY IN THE FUTURE TO ENSURE PROPER FUNCTION AND SAFETY.**

DRILLING:

Most Westin products do not require drilling for installation. If drilling is defined as required, use caution when drilling a vehicle. **FAILURE TO REVIEW AN AREA TO BE DRILLED MAY RESULT IN PERSONAL INJURY AND/OR INJURY TO OTHERS AS WELL AS VEHICLE DAMAGE.**

EYE PROTECTION:

ALWAYS WEAR SAFETY GLASSES OR GOGGLES DURING THE INSTALLATION PROCESS TO AVOID PERSONAL INJURY.

MAXIMUM TOWING/CARRYING CAPACITY:

The Westin Receiver Hitches will have a visible tow rating label affixed directly on the product. User should never exceed the vehicle manufacturers maximum tow and weight rating regardless of the capacity of the hitch. **FAILURE TO FOLLOW THESE GUIDELINES WILL VOID THE WESTIN WARRANTY AND MAY RESULT IN PERSONAL INJURY AND/OR INJURY TO OTHERS AS WELL AS VEHICLE DAMAGE.**

When it comes to quality side steps and nerf bars, Westin is the brand you can depend on.

Westin.
SIGNATURE OF QUALITY