



INSTALLATION INSTRUCTIONS

SURE-GRIP RUNNING BOARD MOUNT KIT

APPLICATION:

2015-2017 Ford F-150 Regular/Super Cab
2015-2017 Ford F-150 Super Crew
2017 Ford F-250/350 Super Duty Regular Cab/Super Cab
2017 Ford F-250/350 Crew Cab

APPLICATION PART #: 27-2175, 27-2195

ITEM	QUANTITY	DESCRIPTION	TOOLS NEEDED
1	4 / 6*	UNIVERSAL MOUNTING BRACKET	16MM SOCKET
2	2 / 4*	BRACKET A	18MM SOCKET
3	2	BRACKET B	18MM WRENCH
4	16 / 24*	M8 FLAT WASHER	RATCHET
5	16 / 24*	M8 SPLIT LOCK WASHER	TORQUE WRENCH
6	16 / 24*	M8 HEX NUT	
7	4 / 6*	M8 ROUND HEAD SQUARE NECK BOLT	
8	8 / 12*	5/16" X 3/4" SQUARE HEAD BOLT	
9	8 / 12*	5/16" FLAT WASHER	
10	8 / 12*	5/16-18 HEX NYLON LOCK NUT	
11	12 / 18*	M8 PLASTIC RETAINER SQUARE	

*QUANTITIES DEPEND UPON APPLICATION PART # (27-2175/27-2195)

ANTI-SEIZE LUBRICANT MUST BE USED ON ALL STAINLESS STEEL FASTENERS TO PREVENT THREAD DAMAGE AND GALLING

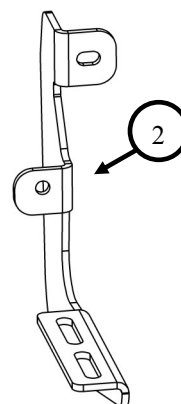
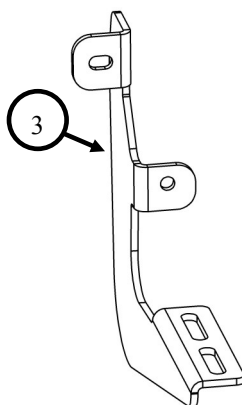
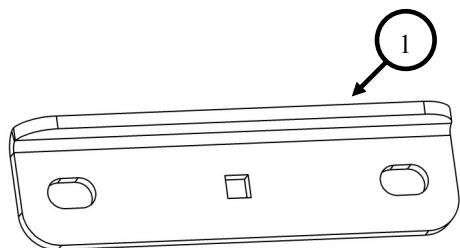

PROCEDURE

1. Remove contents from box, verify if all parts listed are present and free from damage. Carefully read and understand all instructions before attempting installation.
Failure to identify damage before installation could lead to a rejection of any claim.
2. Start installation on the driver's side. On the rocker panel find locations of factory studs. In each location there should be 3 studs. (**Note:** Super Cab has two locations and Super Crew has three locations.) **See Fig. 1.**
3. Insert (1) M8 Plastic Retainer Square (Item 11) on each factory stud. (**Note:** There will be 6 extra plastic retainer squares for the Super Crew model.) **See Fig. 2.**

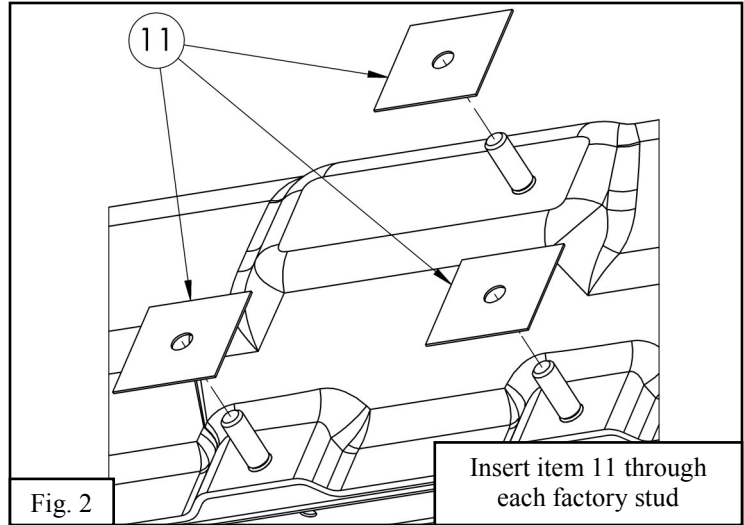
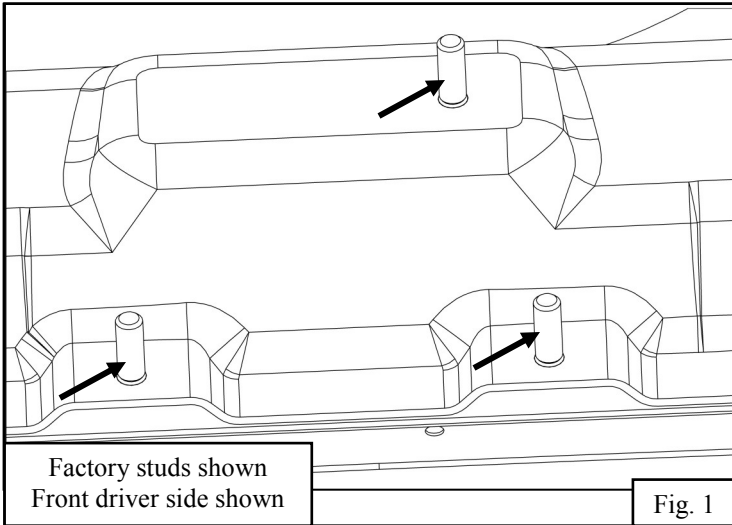

4. Insert the M8 round head square neck bolt (Item 7) through the Universal Mounting Bracket's (Item 1) square hole. Then insert the M8 round head square neck bolt through Bracket B (Item 3) bottom circular hole. Loosely secure Item 1 & 3 with (1) M8 hex nut, (1) M8 split lock washer, and (1) M8 flat washer. (**Note:** For Super Cab model there will be 4 Universal Mounting Brackets and for the Super Crew model there are 6.) **See Fig. 3.**
5. Align sub-assembly with the 3 factory studs. Lower 2 factory studs will align with the Universal Mounting Bracket and top factory stud will align with Bracket B. Loosely secure sub-assembly (Items 1, 3, & 7) with (3) M8 hex nut, (3) M8 split lock washer, and (3) M8 flat washer. **See Fig. 4.**

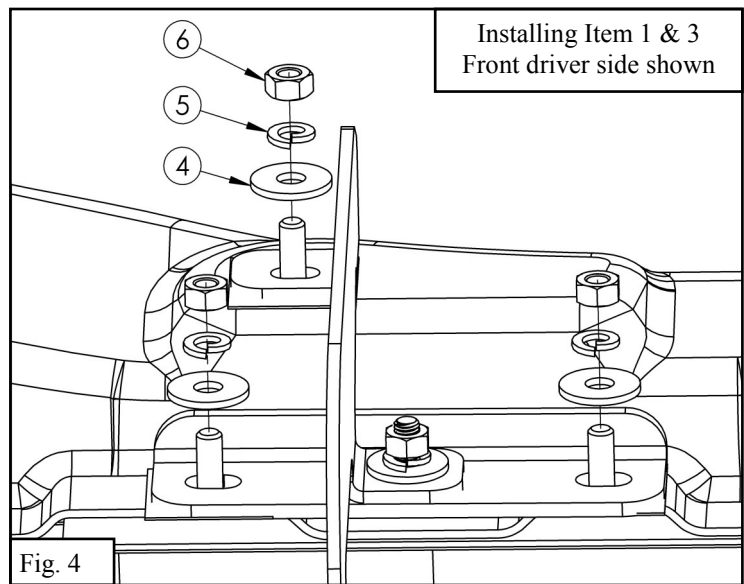
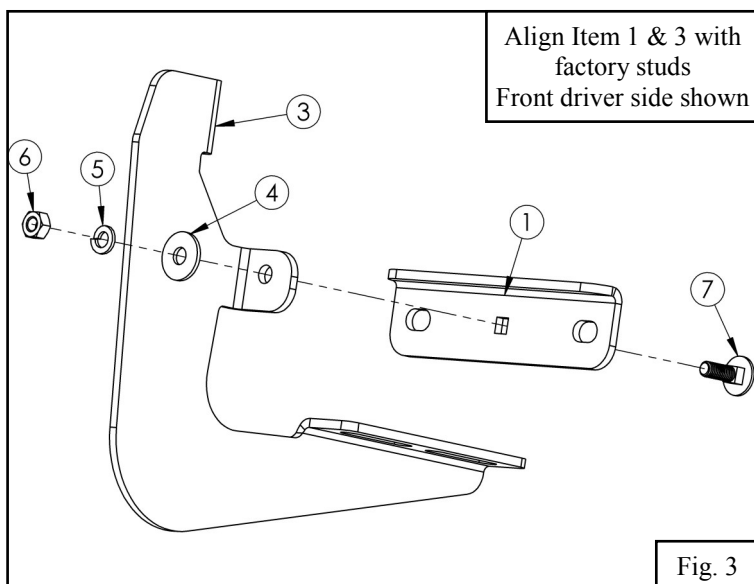

6. For the rear and center location with the factory studs use Bracket A (Item 2) instead of Bracket B (Item 3) and follow steps 4 and 5. (Note: The Super Crew model will have 2 extra Bracket A, due to an extra center location of factory studs.) **See Fig. 5.**
7. Locate the driver side Sure-Grip running board (Sold Separately). Using the provided (4 or 6 depending on number of brackets) 5/16" x 3/4" square head bolts (Item 8) slide them through the square channels in the running board. Slide square head bolts until they align with the brackets slots. **See Fig. 6.**

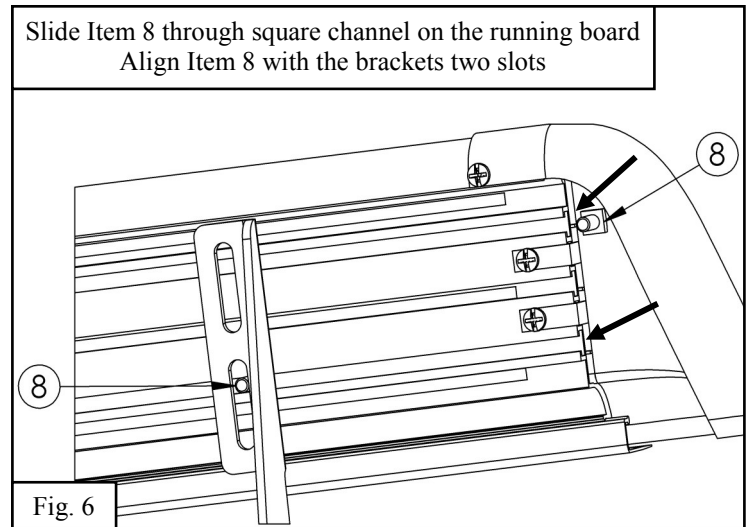
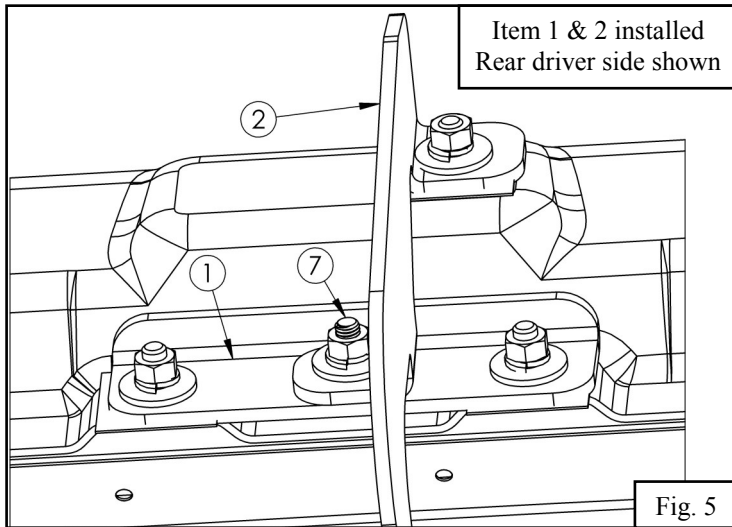

8. Using the provided 5/16" flat washer (Item 9) and 5/16-18 hex nylon lock nut (Item 10), loosely secure the brackets with the running board. **See Fig. 7.**
9. Repeat steps 7 to 8 for the passenger side.
10. Align and adjust running boards and brackets as necessary. Tighten and torque all M8 hardware to 15-18 ft-lbs and 5/16" hardware to 15-18 ft-lbs.

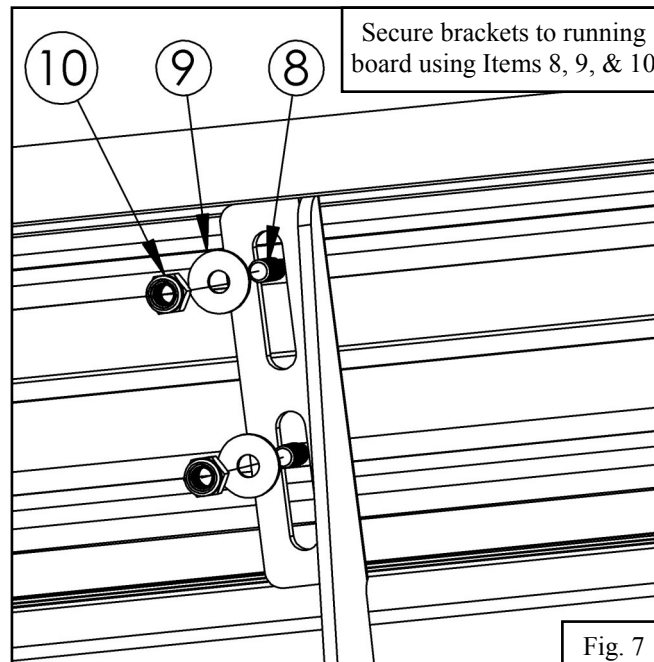



CARE INSTRUCTIONS

- REGULAR WAXING IS RECOMMENDED. DO NOT USE ANY TYPE OF POLISH OR WAX THAT MAY CONTAIN ABRASIVES.
- STAINLESS STEEL PRODUCTS CAN BE CLEANED WITH MILD SOAP AND WATER. STAINLESS STEEL POLISH SHOULD BE USED TO POLISH SMALL SCRATCHES.
- GLOSS BLACK FINISHES SHOULD BE CLEANED WITH MILD SOAP AND WATER.

Westin

SIGNATURE OF QUALITY

AUTOMOTIVE PRODUCTS, INC.



WARNING



Failure to follow these instructions could lead to death, personal injury, and / or property damage.

FASTENERS:

All Westin supplied fasteners must be utilized and installed in accordance with the installation instructions and apply torque to the specifications as defined. **DOUBLE CHECK ALL FASTENERS BEFORE INITIAL USE, AND PERIODICALLY IN THE FUTURE TO ENSURE PROPER FUNCTION AND SAFETY.**

DRILLING:

Most Westin products do not require drilling for installation. If drilling is defined as required, use caution when drilling a vehicle. **FAILURE TO REVIEW AN AREA TO BE DRILLED MAY RESULT IN PERSONAL INJURY AND/OR INJURY TO OTHERS AS WELL AS VEHICLE DAMAGE.**

EYE PROTECTION:

ALWAYS WEAR SAFETY GLASSES OR GOGGLES DURING THE INSTALLATION PROCESS TO AVOID PERSONAL INJURY.

MAXIMUM TOWING/CARRYING CAPACITY:

The Westin Receiver Hitches will have a visible tow rating label affixed directly on the product. User should never exceed the vehicle manufacturers maximum tow and weight rating regardless of the capacity of the hitch. **FAILURE TO FOLLOW THESE GUIDELINES WILL VOID THE WESTIN WARRANTY AND MAY RESULT IN PERSONAL INJURY AND/OR INJURY TO OTHERS AS WELL AS VEHICLE DAMAGE.**

[Learn more about other side steps and nerf bars made by Westin on our website.](#)

Westin

SIGNATURE OF QUALITY