



INSTRUCTIONS-INSTRUCCIONES-CONSIGNES

APPLICATION: 2007-08 FORD EXPLORER SPORT TRAC

AUTOMOTIVE PRODUCTS, INC.

MOUNT KIT 27-1795		SURE GRIP OPTIONAL LIGHT KIT 27-6000			
MOLDED STEP BOARDS 27-0010 27-0015	SURE GRIP BOARDS 27-6130 27-6135 27-6530				

ITEM	QTY	CONTENTS	TOOLS
1	2	STEP BOARD (PURCHASED SEPARATELY)	1/2" SOCKET 1/2" WRENCH RATCHET RATCHET EXTENSION TORQUE WRENCH
2	2	FRONT BRACKET	
3	4	CENTER/REAR BRACKET	
4	12	5/16 18 X 1.00" HEX HEAD BOLT	
5	30	5/16" USS FLAT WASHER	
6	12	5/16" LOCK WASHER	
7	6	5/16 18 HEX NUT	
8	12	5/16 18 X .75" SQUARE HEAD BOLT	
9	12	5/16 18 LOCK NUT	
10	6	EXTRUDED U NUT	

STEP 1. Remove contents from box and check for damage. Verify all parts are present. Read and understand instructions before beginning.
NOTE: If installing Westin step boards on vehicles equipped with factory step boards, the existing factory hardware can be used. The mount brackets will be placed over the mounting stud protruding from the rocker panel, and the factory nuts can be reused. It is strongly recommended to install the Sure Grip Gap Strip for these vehicle applications.

STEP 2. Locate the pair of holes on the bottom of the rocker panel and the square hole next to the round hole on the bottom of the floor pan.
SEE FIGURE 1.

STEP 3. Insert extruded "u" nut through square hole in vehicle floor pan so it is positioned over the round hole. **SEE FIGURE 1.**

STEP 4. Install brackets to the extruded "u" nuts inserted into the vehicle floor pan with 5/16" fasteners as shown. **SEE FIGURE 1.**

STEP 5. Install brackets to vehicle rocker panel with 5/16" fasteners as shown. **SEE FIGURE 1** for hole locations.

STEP 6. Insert square head bolts as shown (3 per slot, 6 per Step board/Running board). **SEE FIGURES 3 AND 4.** **NOTE:** For lighted boards, run wiring harness prior to attaching board to brackets (refer to Step 7). **SEE FIGURES 3 AND 4.** Run longer wire harness on passenger side.

STEP 7. For Sure-Grip Running Boards, slide closure strip as shown. Set lights (if purchased) in appropriate location. Attach to Sure-Grip Running Board as shown. **SEE FIGURE 2.** Drill hole through plastic strip and run wires as shown. **SEE FIGURE 5.**

STEP 8. Attach board to brackets as shown. Make sure board and brackets are properly aligned and tighten fasteners. Recommended torque values are 10 FT.LBS. for 5/16" square head fasteners and 16 FT.LBS. for 5/16" fasteners. **SEE FIGURE 6.**

NOTE: For lighted version of Molded Step Board, remove plastic cover from each end of under side of board. Proceed to Steps 9-10.

WARNING: INSTALLING LIGHT HARNESS REQUIRES SPLICING INTO VEHICLES ELECTRICAL SYSTEM. WESTIN RECOMMENDS USING A PROFESSIONAL FOR THIS INSTALLATION. NOTE: AVOID AREAS OF EXCESSIVE HEAT, VIBRATION, PINCH OR ROTATION WHEN SECURING HARNESS TO VEHICLE. CAUTION: ALWAYS USE A FUSED(+) POSITIVE SUPPLY SOURCE. UNDERCOAT SEAL FOR HARSH WEATHER.

HINT: Molded Step Boards: For longevity, check rubber seals before installation. Rubber grommets around red and blue wires going into rear sockets, should be inserted and recessed about 1/4". **NOTE:** Remove bulbs and apply white grease into sockets and replace bulbs. Apply RTV Silicone where lights go into socket. Install lights and run wire loom as shown. **SEE FIGURE 4.** For Sure-Grip Running Boards, run wire loom down center as shown. **SEE FIGURE 3.**

STEP 9. Determine whether your vehicle has a positive or negative switching courtesy system or an auxiliary light source (most Fords). Obtain an accurate wiring diagram for your vehicle's courtesy light system.

For positive and negative switching:

Locate a pass-through point (usually under carpet at driver side door sill) for the wire harness. Locate main courtesy wire (usually wire lead to dome light). **NOTE:** If you do not use the main courtesy wire, lights will only function when one door is open. Route wire harness so that the 2 female connections (from step board) are nearest to pass thru point.*Connect opposite step board lead to either connection. Connect the splicing lead to remaining female socket and route one wire thru pass thru point. **SEE FIGURE 7.**

VERY IMPORTANT - Double check that your system has positive or negative switching.

For positive switching only: Connect positive wire to main courtesy system, (usually wire lead to dome light). TEST CONTINUITY BEFORE CONNECTING BY OPENING AND CLOSING ALL DOORS. Ground remaining wire.

For negative switching only: Connect negative wire to main courtesy system, (usually wire lead to dome light but sometimes from dome light to courtesy ECU). TEST GROUND CONTINUITY BEFORE CONNECTING BY OPENING AND CLOSING ALL DOORS. Connect remaining wire to battery using a 5A fuse.

**Be sure that you have not routed any wires near moving parts (i.e.. driveshaft) or near any heat generating source (i.e.. transmission, engine, exhaust).

Auxiliary Light source:

Locate auxiliary light source connection under vehicle (usually attached to back side of front or rear fender well (refer to vehicles owners manual). **SEE FIGURE 7.** TEST SOURCE BEFORE CONNECTING. Connect splicing leads to aux light source. test step board lights for proper function by opening and closing doors.

STEP 10. Under-coat board, brackets and electrical wires, connections and lenses for harsh weather conditions. Reinstall plastic cover on underside of Step boards. **INSTALLATION IS COMPLETE.**

FINISH PROTECTION

Westin products have a high quality finish that must be cared for like any other exposed finish on the vehicle. Protect the finish with a non abrasive automotive wax, (e.g. Pure Carnauba) on a regular basis. The use of any soap, polish or wax that contains an abrasive is detrimental, as the compounds scratch the finish and open it to corrosion.

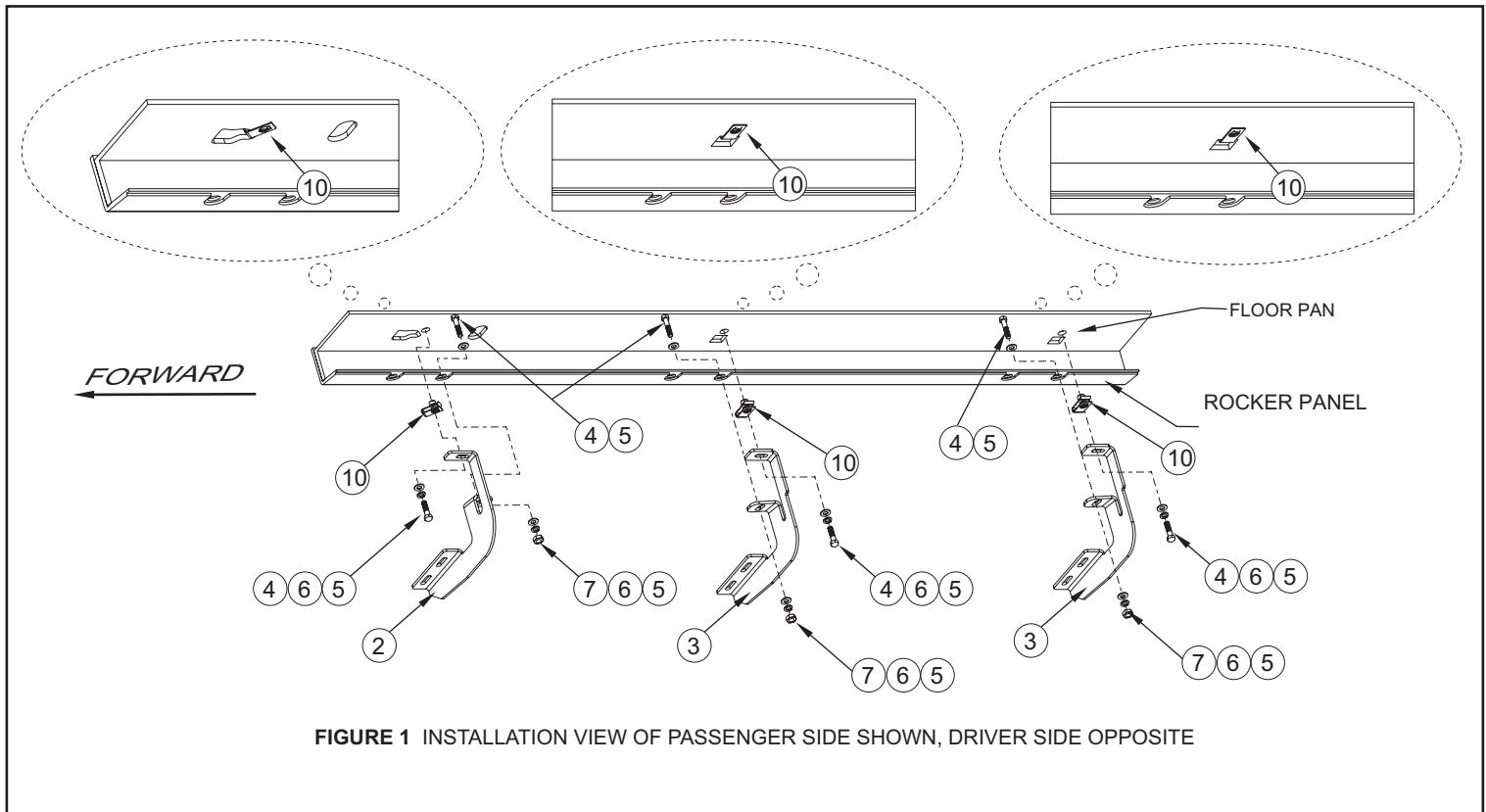

FIGURE 1 INSTALLATION VIEW OF PASSENGER SIDE SHOWN, DRIVER SIDE OPPOSITE

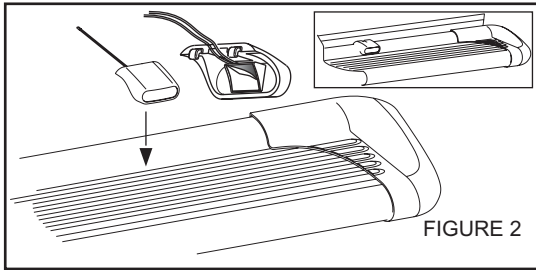

FIGURE 2

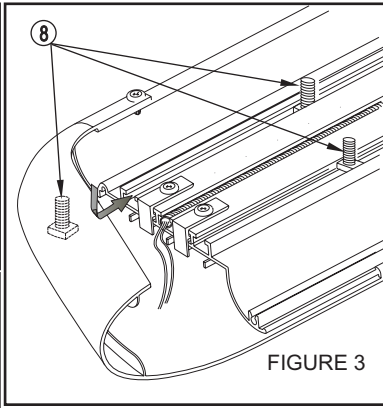

FIGURE 3

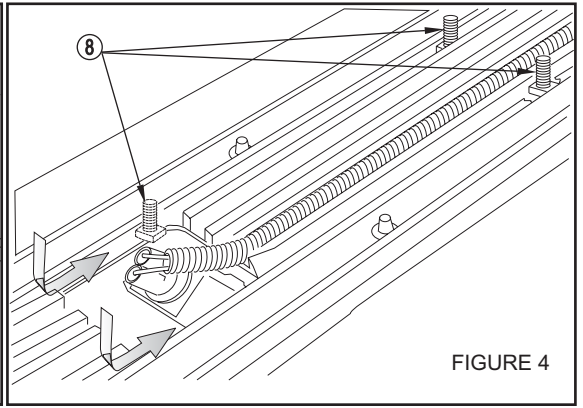

FIGURE 4

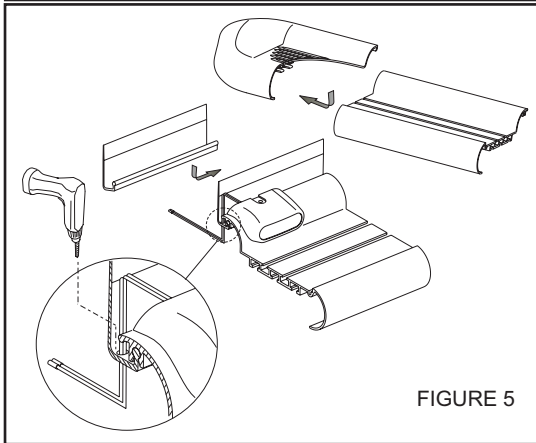

FIGURE 5

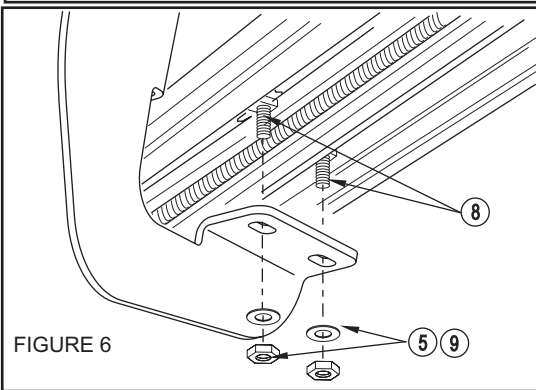

FIGURE 6

