



INSTALLATION INSTRUCTIONS

PLATINUM 4" OVAL WTW STEP BARS APPLICATION:
2015-2017 Ford F-150 Super Cab / Super Crew 6.5'
Bed PART NUMBER:

24-54610, 24-54615, 24-54630, 24-54635

AUTOMOTIVE PRODUCTS,

ITEM	QUANTITY	DESCRIPTION	TOOLS NEEDED
1	2	STEP BAR ASSEMBLY	13MM SOCKET
2	1, 2*	CENTER / REAR DRIVER MOUNT BRACKET	18MM SOCKET
3	1, 2*	CENTER / REAR PASSENGER MOUNT BRACKET	13MM WRENCH
4,5	2	ISOLATOR BOTTOM BRACKET, DRIVER(4) AND PASSENGER(5)	18MM WRENCH
6,7	2	FRONT MOUNT BRACKET, DRIVER(6) AND PASSENGER(7)	RATCHET
8	2, 4*	UNIVERSAL MOUNT BRACKET	TORQUE WRENCH
9,10	2	TOP ISOLATOR BRACKET, DRIVER(9) AND PASSENGER(10)	
11	2	ISOLATOR KIT	
12	14, 22*	M8 HEX NUT (YELLOW ZINC)	
13	14, 22*	M8 FLAT WASHER (YELLOW ZINC)	
14	14, 22*	M8 SPLIT LOCK WASHER (YELLOW ZINC)	
15	4	M10 HEX HEAD BOLT (YELLOW ZINC)	
16	4	M10 U-NUT CLIP (YELLOW ZINC)	
17	4	M10 SPLIT LOCK WASHER (YELLOW ZINC)	
18	4	M10 FLAT WASHER (YELLOW ZINC)	
19	2	M12 SERRATED FLANGE NUT (YELLOW ZINC)	
20	2, 4*	M8 CARRIAGE SQUARE NECK BOLT (BLACK ZINC)	
21	8, 12*	M10 BUTTON HEAD CAP SCREW (BLACK ZINC)	
22	8, 12*	M10 INTERNAL TOOTHED LOCK WASHER (BLACK ZINC)	
23	8, 12*	M10 FLAT WASHER (BLACK ZINC)	
24	12, 18*	M8 PLASTIC RETAINER SQUARE	
25	2	1/2-13X 2" HEX HEAD CAP SCREW (YELLOW ZINC)	
26	2	1/2" SAE FLAT WASHER (YELLOW ZINC)	
27	2	1/2" SPLIT LOCK WASHER (YELLOW ZINC)	

***SUPER CREW HAS MORE BRACKETS AND USES MORE HARDWARE. SUPER CAB WILL HAVE LEFT OVER HARDWARE**

ANTI-SEIZE LUBRICANT MUST BE USED ON ALL STAINLESS STEEL FASTENERS TO PREVENT THREAD DAMAGE AND GALLING

Passenger Side Items Opposite

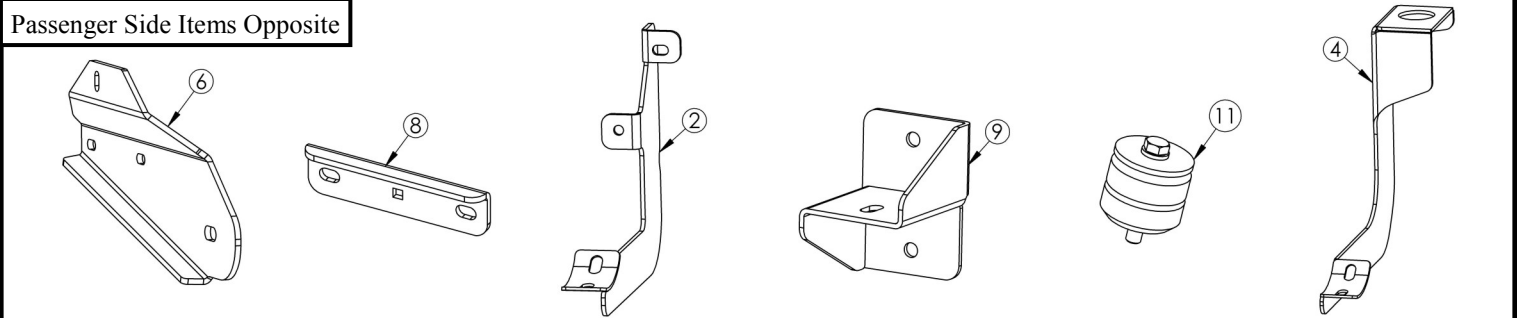

PROCEDURE

1. Remove contents from box, verify if all parts listed are present and free from damage.

Carefully read and understand all instructions before attempting installation.

Failure to identify damage before installation could lead to a rejection of any claim.

2. Locate factory welded studs on the rocker panel. **See Figure 1.**
3. Thread M8 square plastic poly retainer (Item 24) onto each factory studs for driver side. Repeat for passenger side. **See Figure 2.** (Note: The plastic poly retainers are necessary to prevent reaction between supplied steel equipment and aluminum rocker panel.)

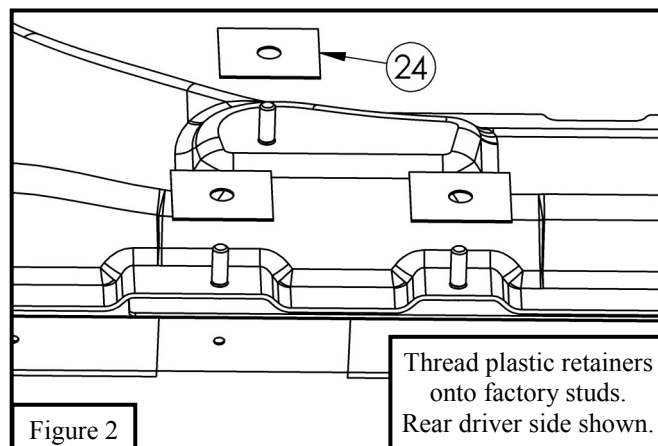
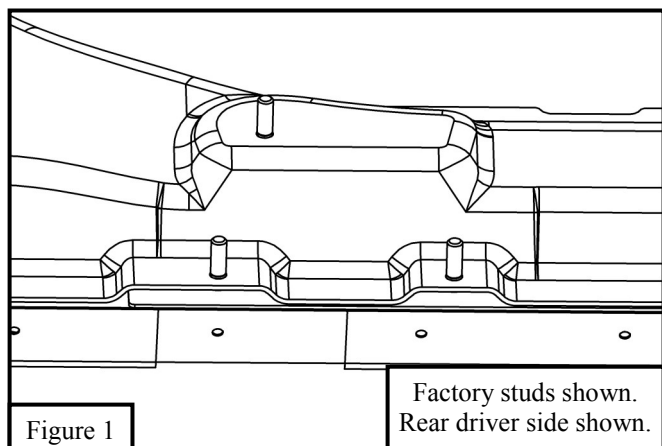

4. Starting on the driver side, locate (1) driver front mount bracket (Item 6) and loosely secure to factory studs using (3) M8 hex nuts, (3) M8 flat washers and (3) M8 split lock washers. **See Figure 3.**
5. Repeat step 4 for passenger side.
6. Loosely install the universal support brackets (Item 8) to the center and rear mounting brackets with supplied (1) M8 carriage square neck bolt, (1) M8 hex nut, (1) M8 flat washer and (1) M8 split lock washers. **See Figure 4.**

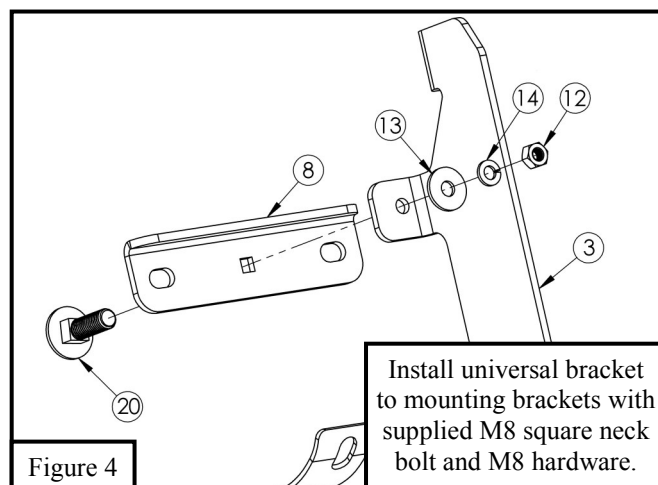
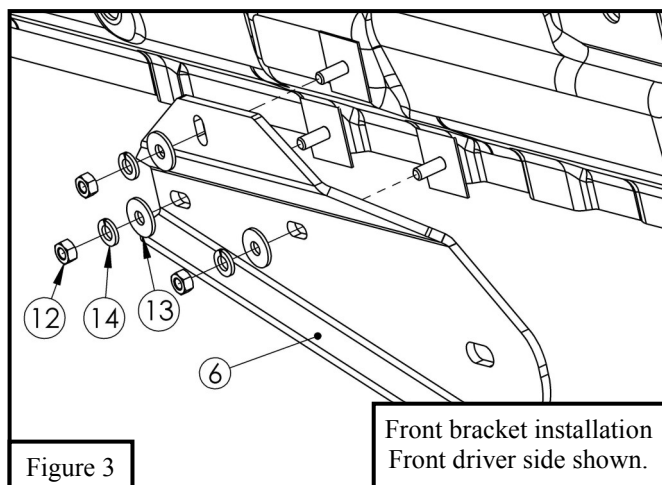

7. Loosely install driver side mounting brackets to rocker panel with supplied M8 hardware. Repeat for passenger side. **See Figure 5.**
8. Starting at driver side, locate two circular and two square holes on the frame, located near the rear of vehicle. **See Figure 6.**
9. Using (2) M10 U-Nut Clip (Item 15), insert them into the square holes on frame. Make sure that the circular holes of the frame are aligned with the circular holes of the M10 U-Nut Clips. **See Figure 7.**

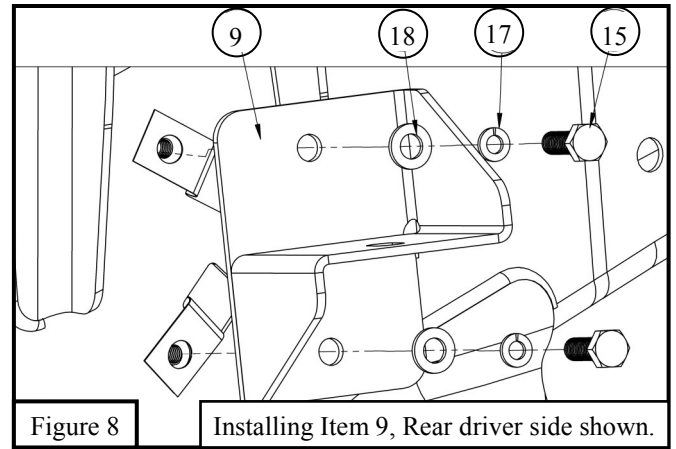
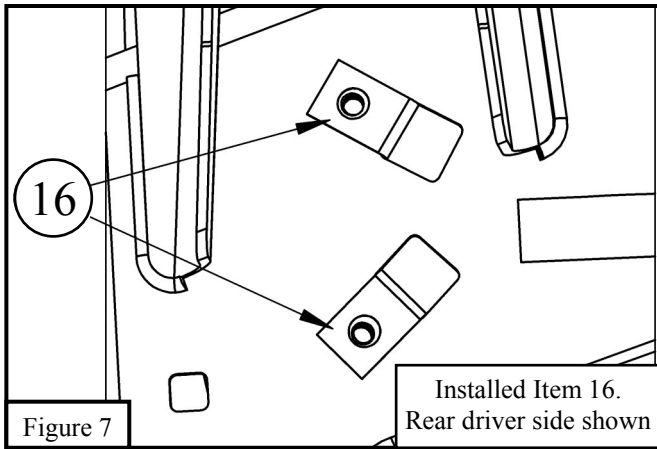
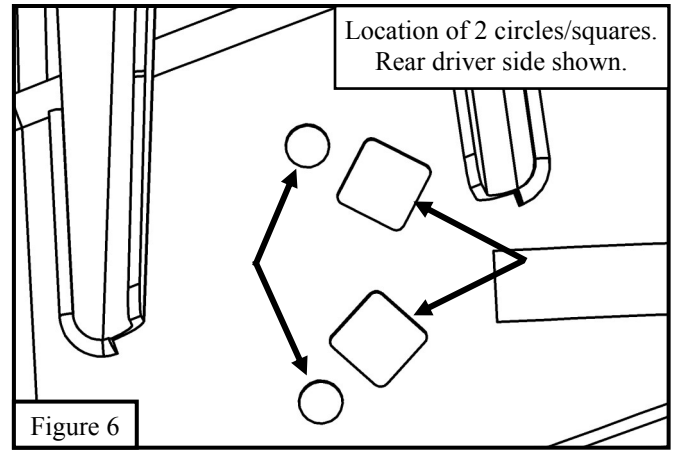
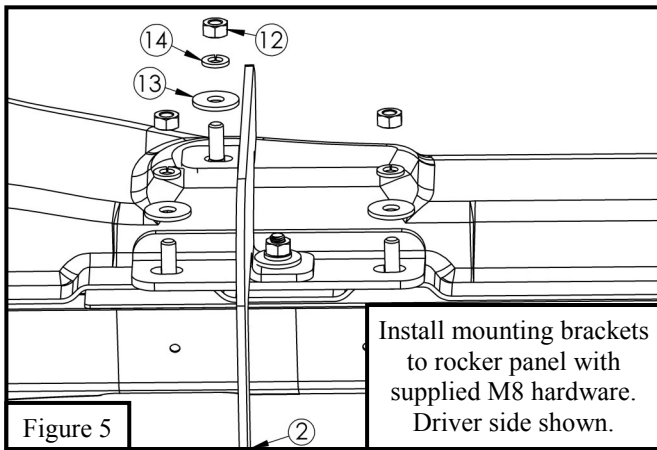

10. Locate driver top isolator bracket (Item 9). Align holes of the driver top isolator bracket with the holes of the frame and u-nut clips. Using (2) M10 hex head bolts, (2) M10 split lock washers, and (2) M10 flat washers loosely secure the driver top isolator bracket to the frame. **See Figure 8.**
11. Locate the isolator kit (Item 11). Isolator kit should have (1) isolator sleeve, (1) top isolator, (1) bottom isolator, (1) isolator washer, (1) M12 split lock washer and (1) M12 bolt. Assemble the isolator kit with the driver bottom isolator bracket (Item 6) using provided M12 serrated flange nut (Item 19). **See Figure 9.**
12. Install assembly (Item 4 & Item 11) onto the driver top isolator bracket (Item 9). Loosely install using the provided (1) M12 serrated nut that comes with the provided hardware. **See Figure 10.**
13. Repeat steps 8 - 12 for passenger side.

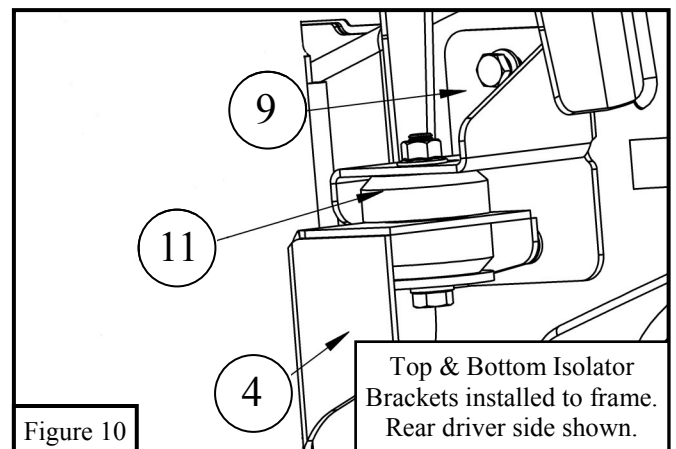
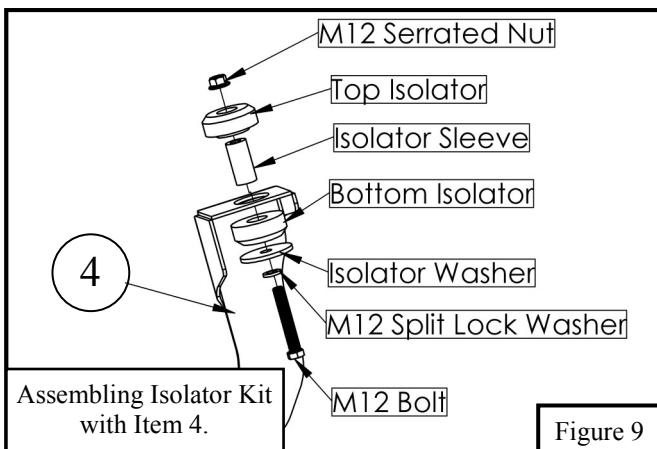

14. Locate the driver step bar assembly (Item 1) and align it with the brackets. (**Note:** Super Cab model will have 3 brackets and Super Crew will have 4 brackets.) **Refer to Figures 11 and 12 for bracket orientation.**
15. Loosely install the driver step bar assembly using (1) 1/2-13x2" hex head cap screw, (1) 1/2" flat washer and (1) 1/2" split lock washer for the front bracket installation. Use the following hardware for the rest of the brackets: M10 button head cap screw (Item 21), M10 internal toothed lock washer (Item 22), and M10 flat washer (Item 23). (**Note:** Super Cab model with have extra hardware.) **See Figure 13.**
16. Align and adjust the step bar and brackets as necessary then tighten and torque all fasteners as follows: M8 to 15-18 ft-lbs, M10 30-35 ft-lbs.
17. Repeat for the passenger side.

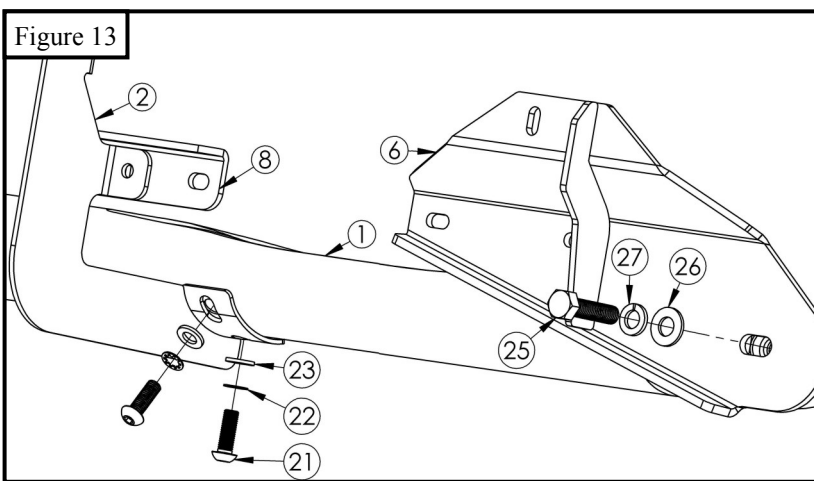
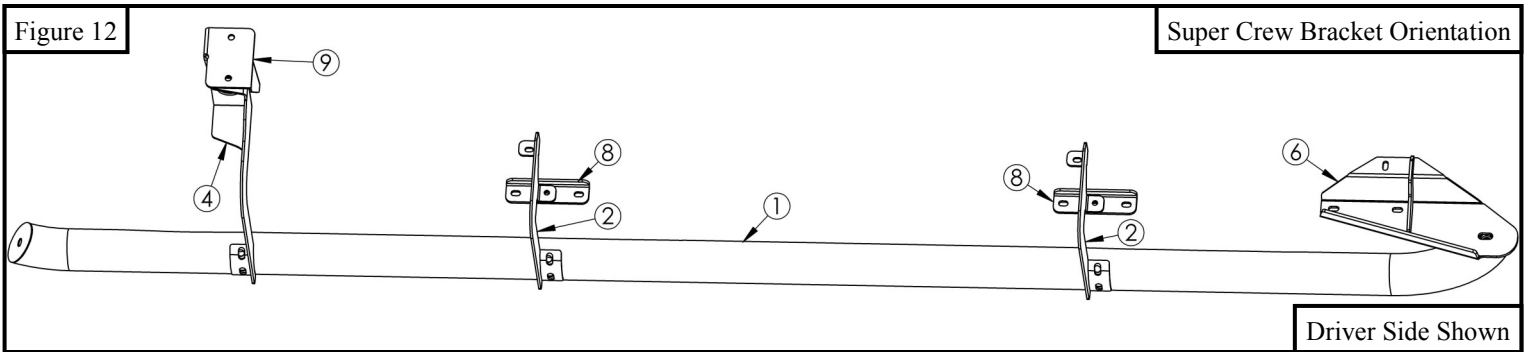
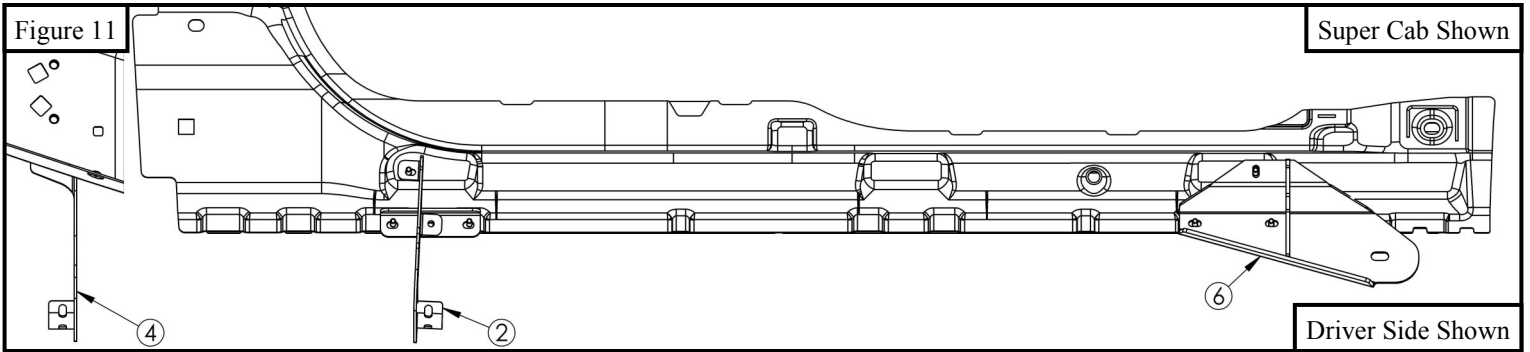

CARE INSTRUCTIONS

- REGULAR WAXING IS RECOMMENDED. DO NOT USE ANY TYPE OF POLISH OR WAX THAT MAY CONTAIN ABRASIVES.
- STAINLESS STEEL PRODUCTS CAN BE CLEANED WITH MILD SOAP AND WATER. STAINLESS STEEL POLISH SHOULD BE USED TO POLISH SMALL SCRATCHES.
- GLOSS BLACK FINISHES SHOULD BE CLEANED WITH MILD SOAP AND WATER.

Westin

SIGNATURE OF QUALITY

AUTOMOTIVE PRODUCTS, INC.



WARNING



Failure to follow these instructions could lead to death, personal injury, and / or property damage.

FASTENERS:

All Westin supplied fasteners must be utilized and installed in accordance with the installation instructions and apply torque to the specifications as defined. **DOUBLE CHECK ALL FASTENERS BEFORE INITIAL USE, AND PERIODICALLY IN THE FUTURE TO ENSURE PROPER FUNCTION AND SAFETY.**

DRILLING:

Most Westin products do not require drilling for installation. If drilling is defined as required, use caution when drilling a vehicle. **FAILURE TO REVIEW AN AREA TO BE DRILLED MAY RESULT IN PERSONAL INJURY AND/OR INJURY TO OTHERS AS WELL AS VEHICLE DAMAGE.**

EYE PROTECTION:

ALWAYS WEAR SAFETY GLASSES OR GOGGLES DURING THE INSTALLATION PROCESS TO AVOID PERSONAL INJURY.

MAXIMUM TOWING/CARRYING CAPACITY:

The Westin Receiver Hitches will have a visible tow rating label affixed directly on the product. User should never exceed the vehicle manufacturers maximum tow and weight rating regardless of the capacity of the hitch. **FAILURE TO FOLLOW THESE GUIDELINES WILL VOID THE WESTIN WARRANTY AND MAY RESULT IN PERSONAL INJURY AND/OR INJURY TO OTHERS AS WELL AS VEHICLE DAMAGE.**

When it comes to quality side steps and nerf bars, Westin is the brand you can depend on.

Westin

SIGNATURE OF QUALITY