



AUTOMOTIVE PRODUCTS,

INSTALLATION INSTRUCTIONS

PRO TRAXX 5" OVAL TUBE STEP BAR

APPLICATIONS:

2014+ CHEVY SILVERADO/GMC SIERRA 1500 REGULAR CAB
 2015+ CHEVY SILVERADO/GMC SIERRA 2500/3500 REGULAR CAB
 GAS & DIESEL

PART NUMBER:

21-53700,21-53705,21-53840,21-53845

CONTENT			
ITEM	QUANTITY	DESCRIPTION	TOOLS NEEDED
1	1	STEP BAR DRIVER SIDE	13MM SOCKET
2	1	STEP BAR PASSENGER SIDE	13MM WRENCH
3	3	MOUNT BRACKET B	TORQUE WRENCH
4	1	MOUNT BRACKET C	RATCHET
5	8	M8 X 25 MM HEX HEAD BOLT	HEX KEY TOOL (INCLUDED)
6	8	M8 FLAT WASHER	
7	8	M8 SPLIT LOCK WASHER	
8	8	M8 NUT CLIP	
9	8	M10 HEX SOCKET BUTTON HEAD BOLT	
10	8	M10 TOOTHED LOCK WASHERS	
11	8	M10 FLAT WASHERS	

ANTI-SEIZE LUBRICANT MUST BE USED ON ALL STAINLESS STEEL FASTENERS TO PREVENT THREAD DAMAGE AND GALLING

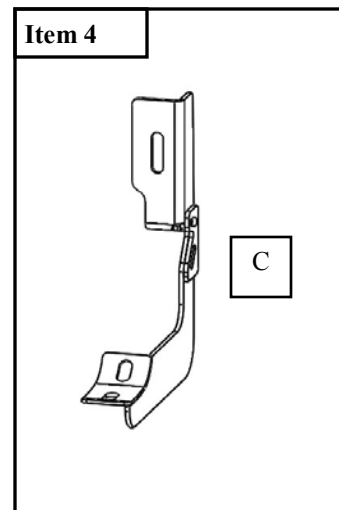
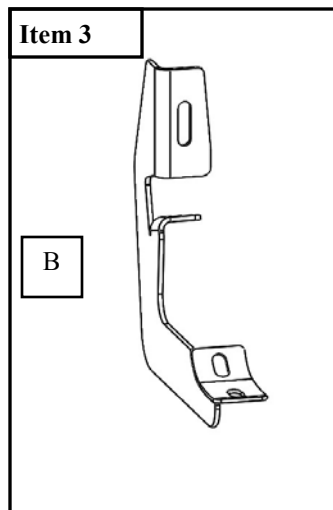
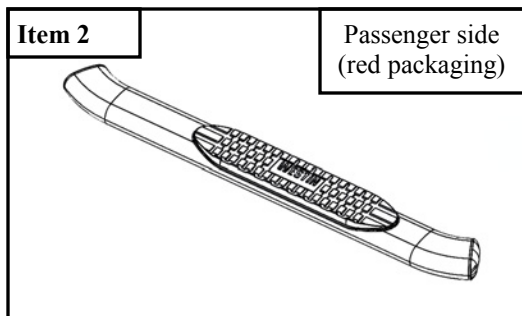
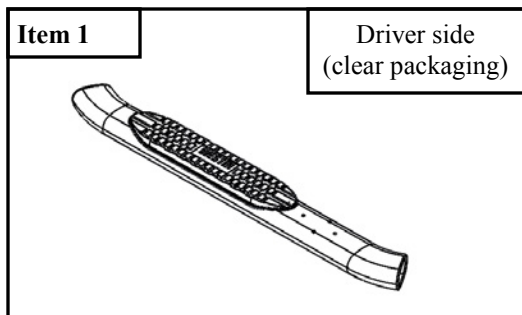

PROCEDURE

1. Remove contents from box, verify if all parts listed are present and free from damage. Carefully read and understand all instructions before attempting installation. **Failure to identify damage before installation could lead to a rejection of any claim.**
2. **Step two-**Locate on each rocker panel the black rubber plugs and remove them **SEE FIGURE 1**. Install the M8 nut clips (item 8) as shown in **FIGURE 3**. For the bracket C (item 4) mount location, install M8 nut clip (item 8) as shown in **FIGURE 2**.

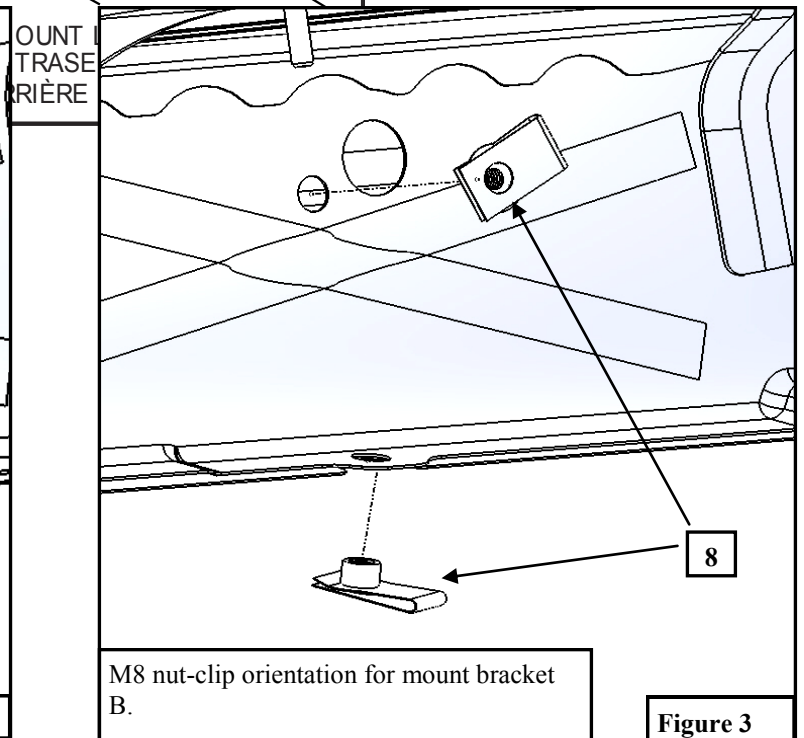
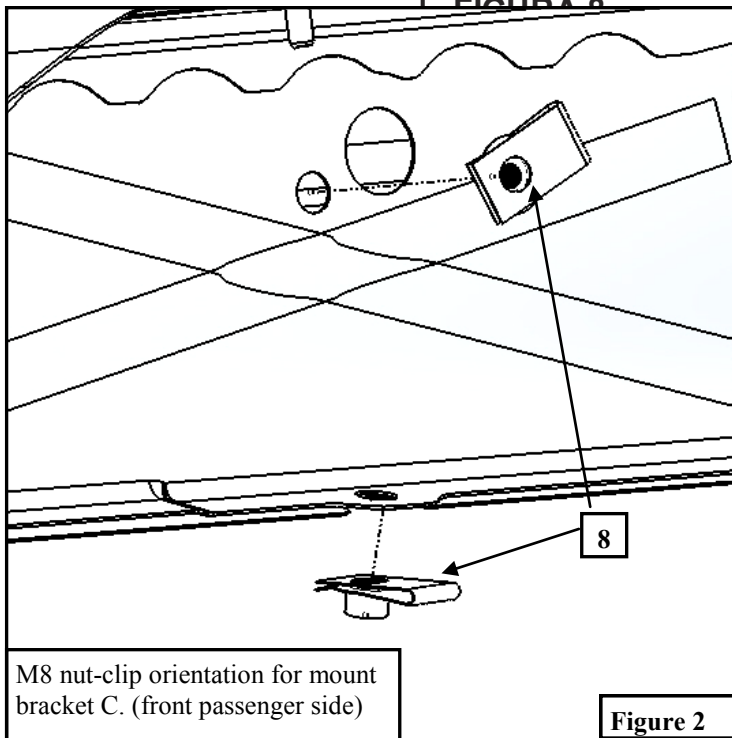
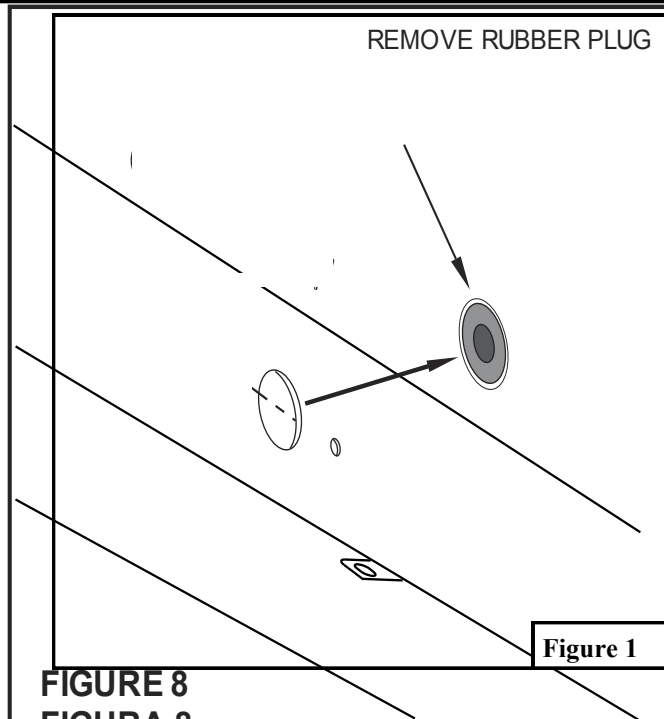

3. **Step three**-take the mounting brackets and install the bracket and associated hardware loosely to it's corresponding positions **SEE FIGURE 4,5,6 and 7**. Brackets used for passenger side are (1) bracket C (item 4) and (1) bracket B (item 3). The driver side will use the remaining (2) bracket B (item 3). **Do not fully tighten hardware at this time. For 2015+ Diesel equipped models, the D.E.F tank must be removed prior to installing the brackets on the passenger side. For D.E.F tank removal instructions please refer to page 5. Note: bracket location is critical.**

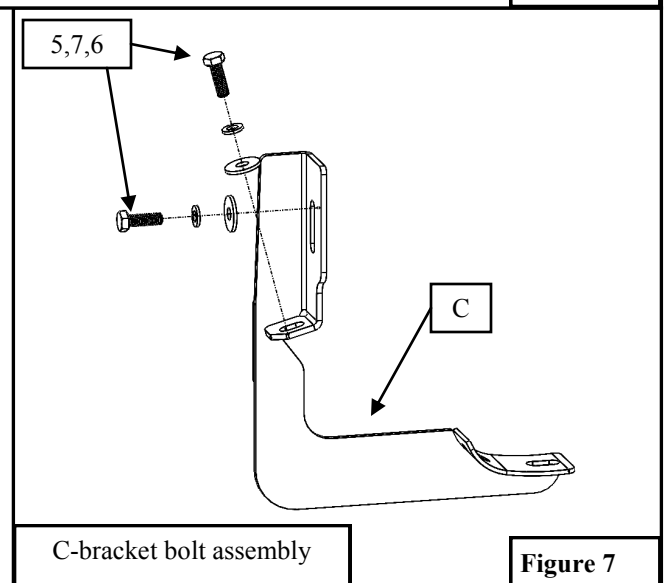
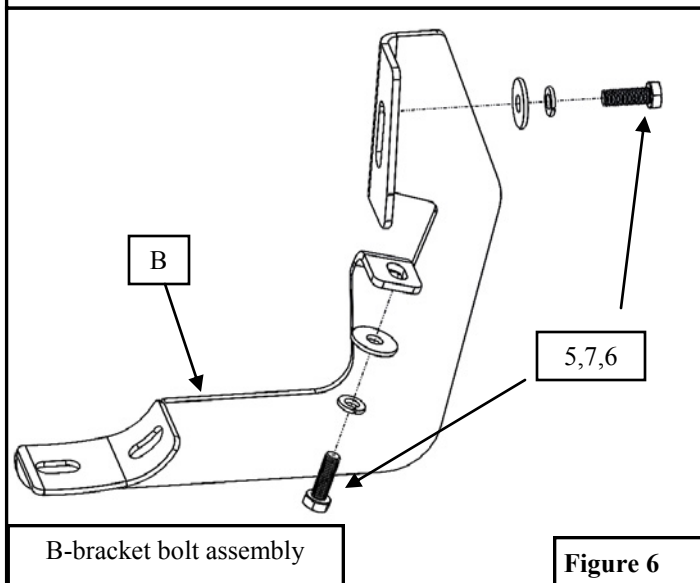
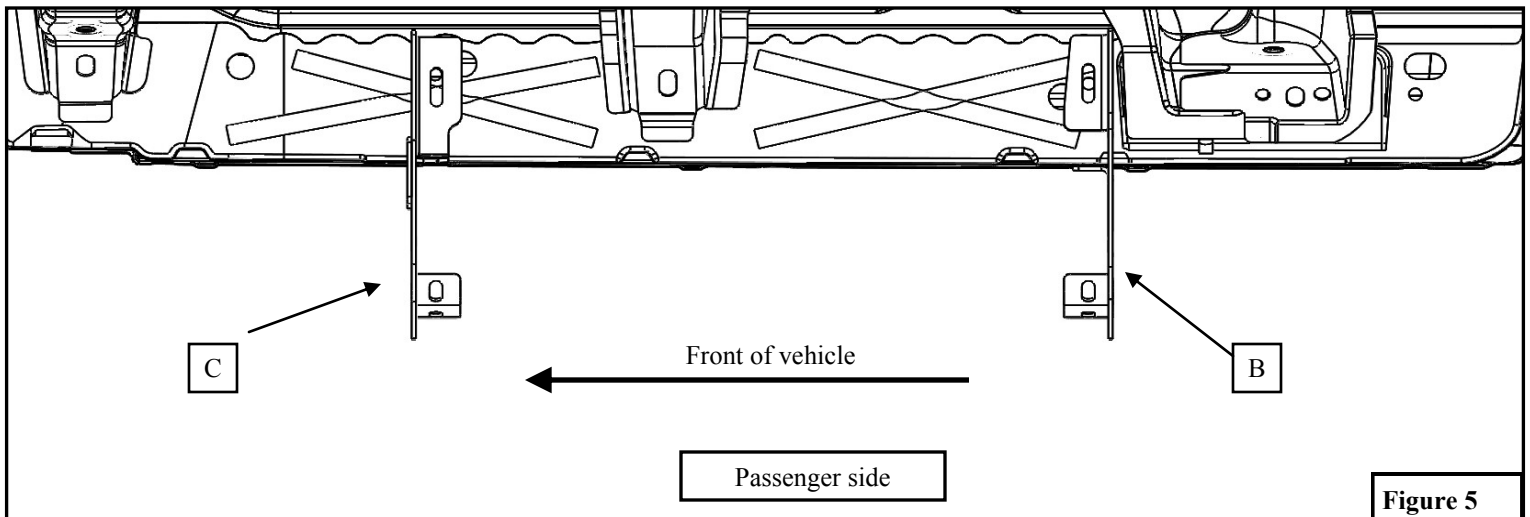
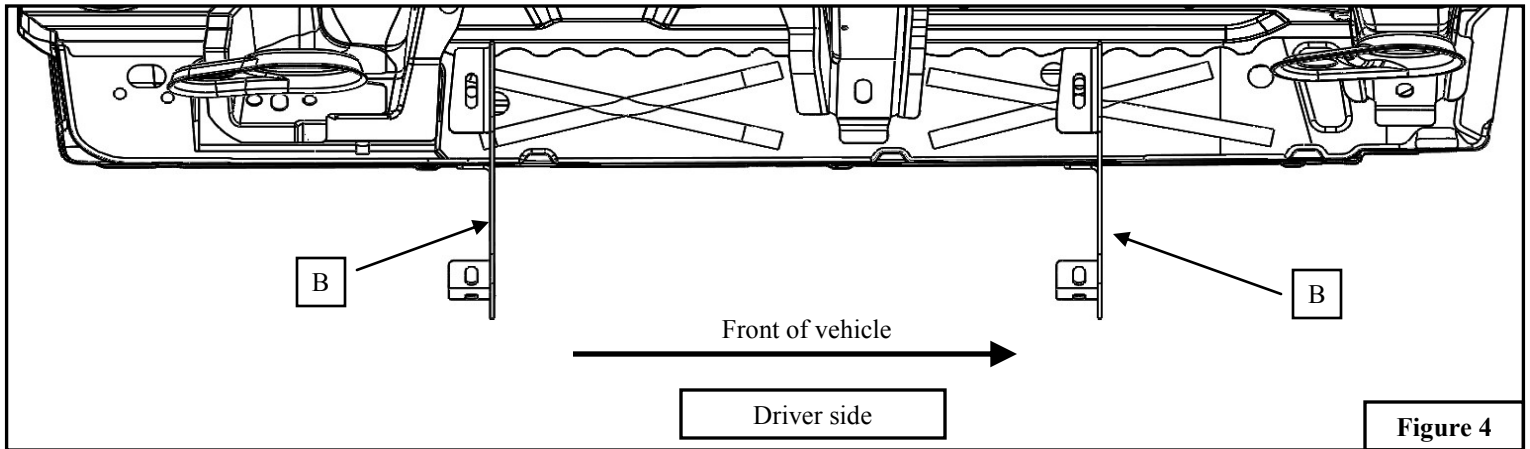

3. **Step four**-take the passenger side step bar (item 2) and place the step bar onto the bracket mounting cradles as shown in **FIGURE 8**. Secure the passenger side step bar (item 2) using (4) M10 button head bolts (item 9), (4) M10 toothed lock washers (item 10) and (4) M10 flat washers (item 11) as shown in **FIGURE 9**. Follow same steps to install driver side step bar (item 1). *Note: the drivers side step bar will be packaged in a clear poly tube and the passenger side will be packaged in a red poly tube, the Westin logo should face outward when installed.*
4. **Step five**-make sure the mounting brackets and step bar are aligned then proceed to fully tighten all hardware. Recommended torque values are 18 ft-lbs for M8 hex head bolts and 30-33 ft-lbs for the M10 button head bolts.
5. **Step six**-proceed to reinstall the D.E.F tank on 2015+ diesel models.

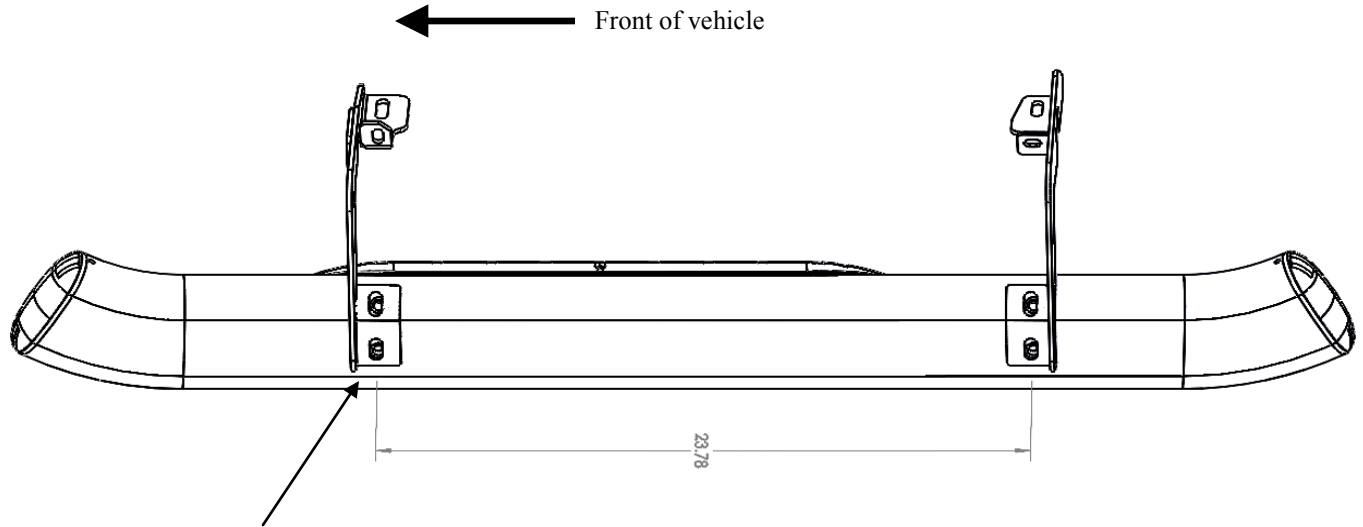

Align the slots on the bracket mounting cradle and step bar.

Dimensions for reference only

Figure 8

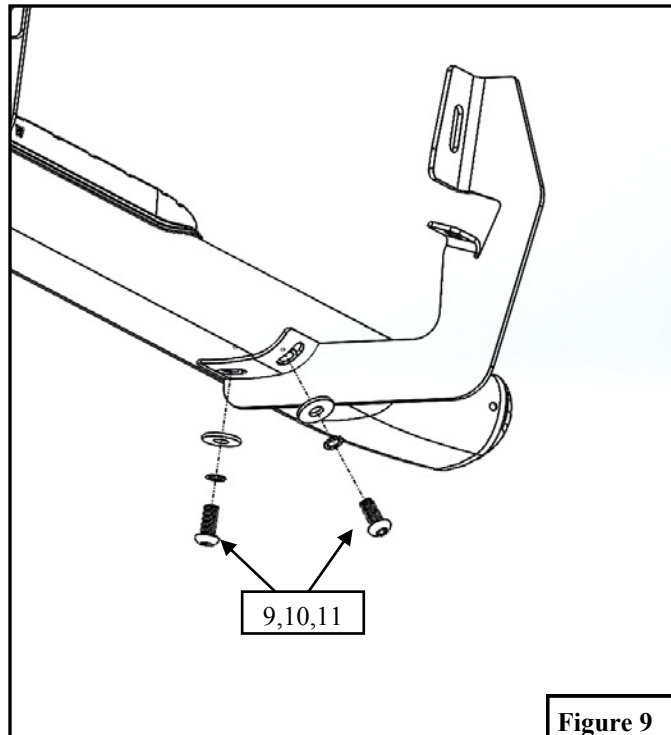
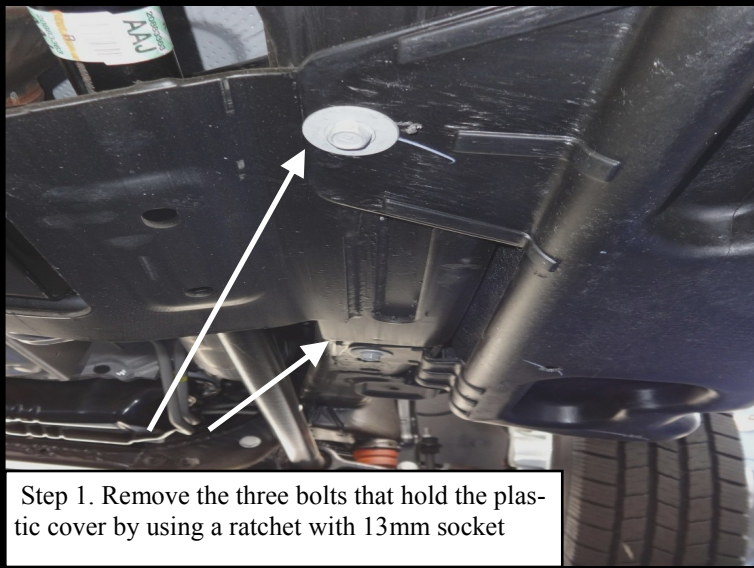
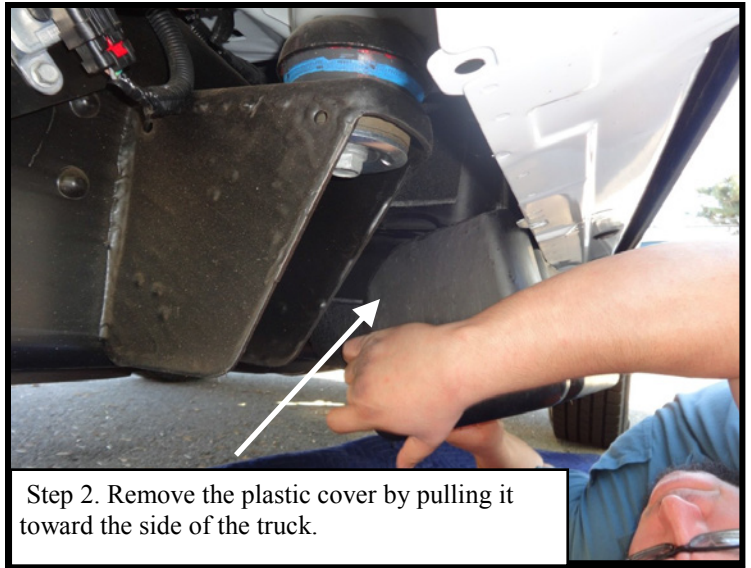

Figure 9

DEF TANK REMOVAL INSTRUCTIONS FOR 11-15 DIESEL MODELS ONLY



Step 1. Remove the three bolts that hold the plastic cover by using a ratchet with 13mm socket



Step 2. Remove the plastic cover by pulling it toward the side of the truck.

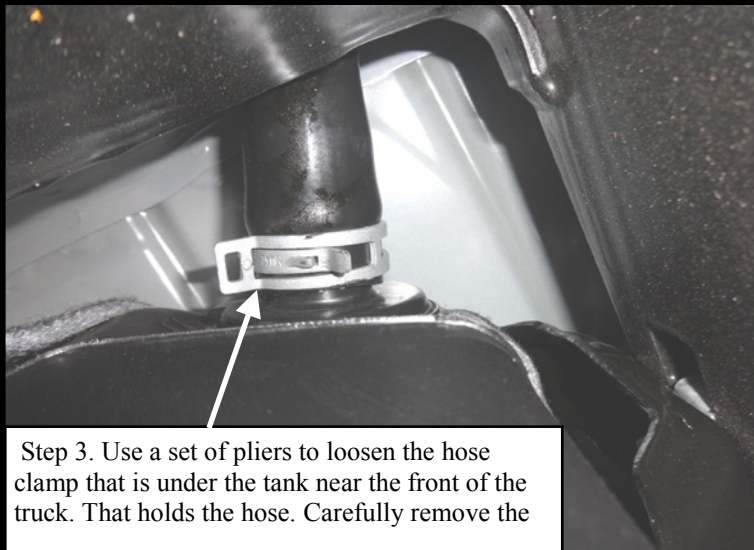

Step 3. Use a set of pliers to loosen the hose clamp that is under the tank near the front of the truck. That holds the hose. Carefully remove the

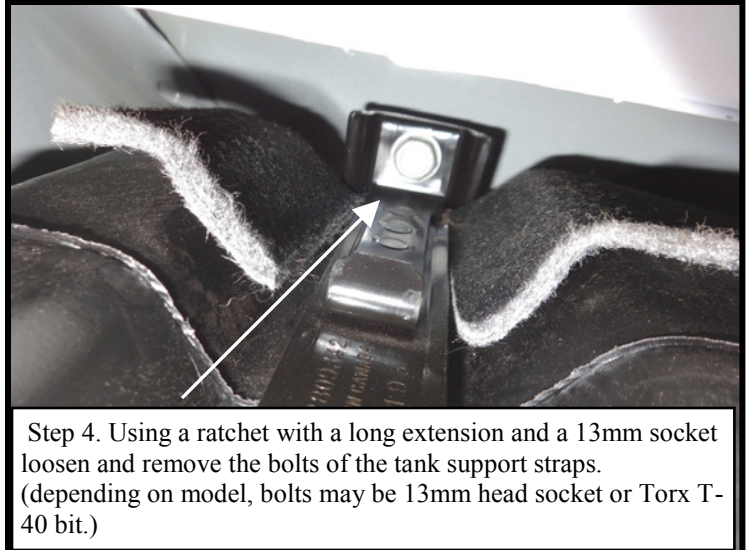

Step 4. Using a ratchet with a long extension and a 13mm socket loosen and remove the bolts of the tank support straps. (depending on model, bolts may be 13mm head socket or Torx T-40 bit.)

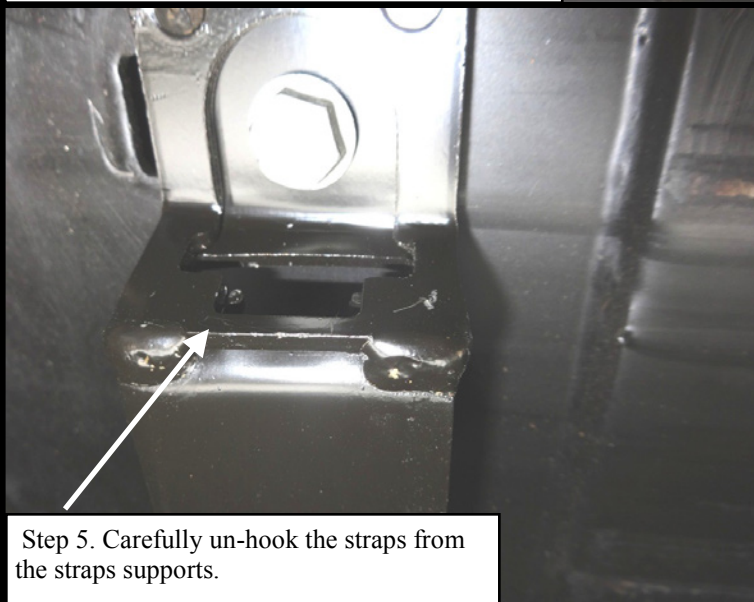

Step 5. Carefully un-hook the straps from the straps supports.

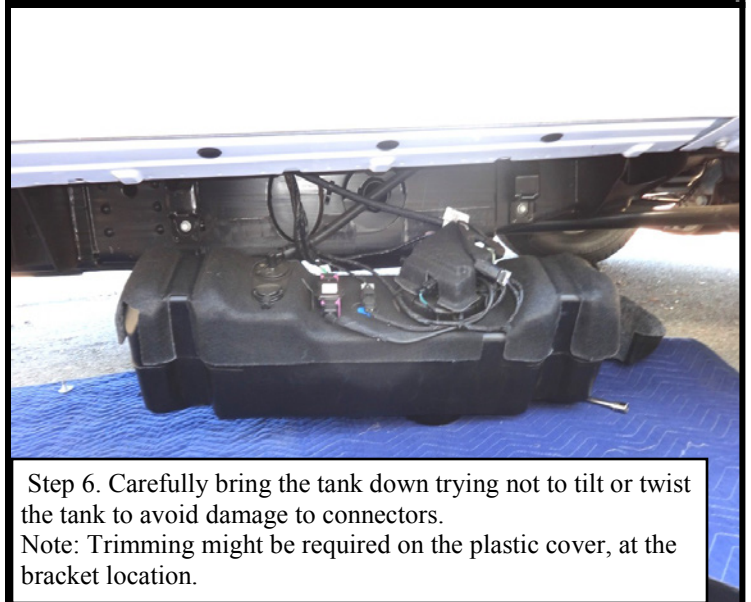

Step 6. Carefully bring the tank down trying not to tilt or twist the tank to avoid damage to connectors.
Note: Trimming might be required on the plastic cover, at the bracket location.



INSTALLATION COMPLETE

CARE INSTRUCTIONS

- Regular waxing is recommended. Do not use any type of polish or wax that may contain abrasives.
- Stainless steel products can be cleaned with mild soap and water. Stainless steel polish should be used to polish small scratches.
- Gloss black finishes should be cleaned with mild soap and water.

Westin

SIGNATURE OF QUALITY

AUTOMOTIVE PRODUCTS, INC.



WARNING



Failure to follow these instructions could lead to death, personal injury, and / or property damage.

FASTENERS:

All Westin supplied fasteners must be utilized and installed in accordance with the installation instructions and apply torque to the specifications as defined. **DOUBLE CHECK ALL FASTENERS BEFORE INITIAL USE, AND PERIODICALLY IN THE FUTURE TO ENSURE PROPER FUNCTION AND SAFETY.**

DRILLING:

Most Westin products do not require drilling for installation. If drilling is defined as required, use caution when drilling a vehicle. **FAILURE TO REVIEW AN AREA TO BE DRILLED MAY RESULT IN PERSONAL INJURY AND/OR INJURY TO OTHERS AS WELL AS VEHICLE DAMAGE.**

EYE PROTECTION:

ALWAYS WEAR SAFETY GLASSES OR GOGGLES DURING THE INSTALLATION PROCESS TO AVOID PERSONAL INJURY.

MAXIMUM TOWING/CARRYING CAPACITY:

The Westin Receiver Hitches will have a visible tow rating label affixed directly on the product. User should never exceed the vehicle manufacturers maximum tow and weight rating regardless of the capacity of the hitch. **FAILURE TO FOLLOW THESE GUIDELINES WILL VOID THE WESTIN WARRANTY AND MAY RESULT IN PERSONAL INJURY AND/OR INJURY TO OTHERS AS WELL AS VEHICLE DAMAGE.**

Feel the difference with Westin.

Check out the collection of side steps and nerf bars we offer.