



INSTALLATION INSTRUCTIONS

PRO TRAXX 5 WHEEL TO WHEEL

AUTOMOTIVE PRODUCTS, INC.

APPLICATION: SILVERADO/ SIERRA (EXCL. 2007 CLASSIC)
 2007-2015 1500 CREW CAB (5.5FT BED) & (6.5FT BED)
 2014-2015 1500 DOUBLE CAB (6.5FT BED)
 2007-2013 1500 EXTENDED CAB (6.5FT BED) & (8FT BED)
 2008-2015 2500/3500 CREW CAB (6.5FT BED), (8FT BED) & DUAL REAR WHEEL (8FT BED)
 2015- + 2500/3500 DOUBLE CAB (8FT BED)
 2008-2014 2500/3500 EXTENDED CAB (6.5FT BED), (8FT BED) & DUAL REAR WHEEL (8FT BED)

APPLICATION PART # 21-534560/65, 21-534570/75, 21-534580/85, 21-534590/95, 21-534600/05

ITEM	QUANTITY	DESCRIPTION	TOOLS NEEDED
1	1	Driver Step Bar	3/8 Ratchet
2	1	Passenger Step Bar	13MM Socket
3	3	Mounting Bracket A	18MM Socket
4	4*	Mounting Bracket B (qty. of 2)*	Flat Screw Driver
5	1	Mounting Bracket C	3/8 Ratchet Extension
6	2*	Mounting Bracket D (Only for 21-534560/65)	
7	1*	Isolator Mounting Bracket Driver (EXCLUDES 21-534560/65)	Torque Wrench
8	1*	Isolator Bracket Driver (EXCLUDES 21-534560/65)	Pliers
9	1*	Isolator Mounting Bracket Passenger (EXCLUDES 21-534560/65)	
10	1*	Isolator Bracket Passenger (EXCLUDES 21-534560/65)	
11	2*	Isolator Rubber Mounting Assembly (EXCLUDES 21-534560/65)	
12	18*	M8 x 16mm O.D. Flat Washers (qty. of 16)* Yellow Zinc	
13	18*	M8 Spring Lock Washers (qty. of 16)* Yellow Zinc	
14	16	M8 Extruded U-Nuts Yellow Zinc	
15	18*	M8 x 30mm Hex Cap Screws (qty. of 16)* Yellow Zinc	
16	20*	M10 Internal Toothed Lock Washers (qty of 16)* Black Zinc	
17	20*	M10 x 25mm Button Head Socket Cap Screws (qty. of 16)* Black Zinc (Stainless Steel)	
18	20*	M10 x 20mm O.D. FLAT WASHERS (qty. of 16)* Black Zinc	
19	2*	M12 x 5mm Thick Spacer (EXCLUDES 21-534560/65) Black Zinc	

***Quantity containing an asterisk has a change in quantity for 21-534560/65 only and is displayed at the end of description.**

ANTI-SEIZE LUBRICANT MUST BE USED ON ALL STAINLESS STEEL FASTENERS TO PREVENT THREAD DAMAGE AND GALLING.

IMPORTANT ALERT: GM uses a very strong thread-locking compound on all body bolts. Use of an air assisted impact ratchet can cause damage to the threads on factory body mount bolts and the internal nut assembly because of this thread locking compound.

We only recommend the use of hand tools to slowly remove and reinstall body mount bolts on all GM vehicles.

CARE INSTRUCTIONS

- REGULAR WAXING IS RECOMMENDED. DO NOT USE ANY TYPE OF POLISH OR WAX THAT MAY CONTAIN ABRASIVES.
- STAINLESS STEEL PRODUCTS CAN BE CLEANED WITH MILD SOAP AND WATER. STAINLESS STEEL POLISH SHOULD BE USED TO POLISH SMALL SCRATCHES.
- GLOSS BLACK FINISHES SHOULD BE CLEANED WITH MILD SOAP AND WATER.

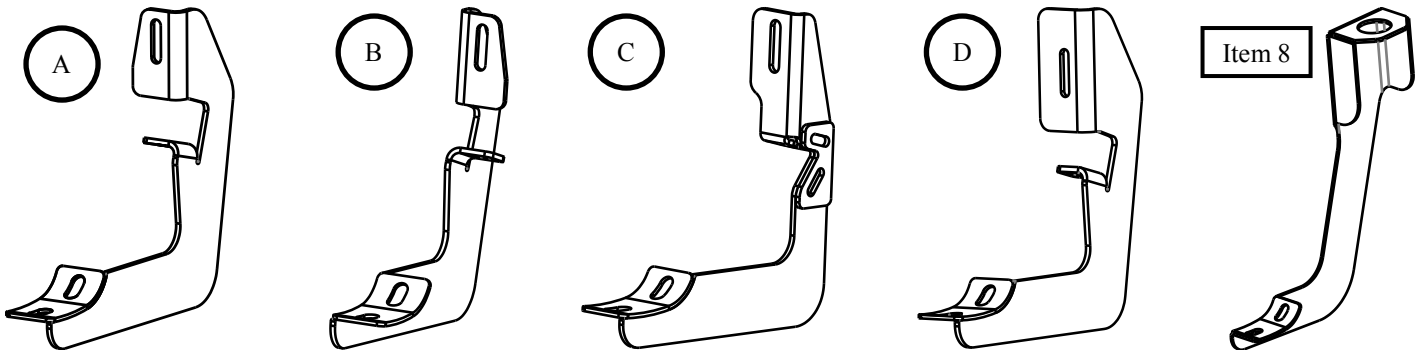

1. Remove all contents from box, verify if all parts listed are present and free from damage. Carefully read and understand all instructions before attempting installation.
2. If the Vehicle is equipped with diesel, proceed to page 5 for removal procedure.

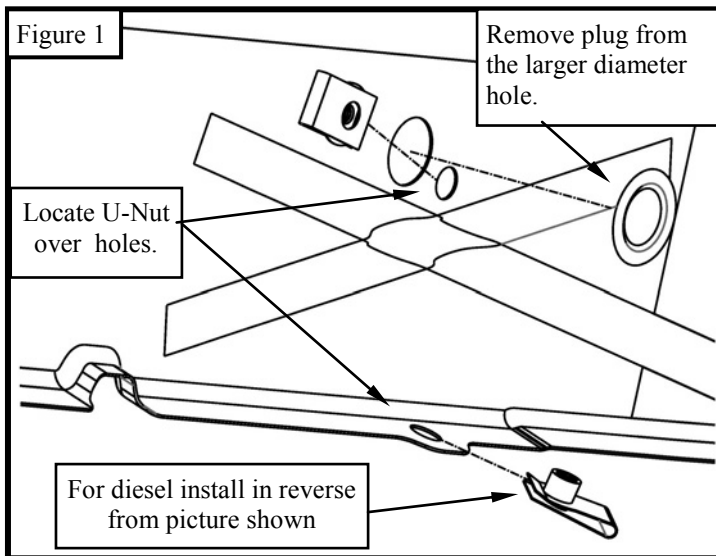
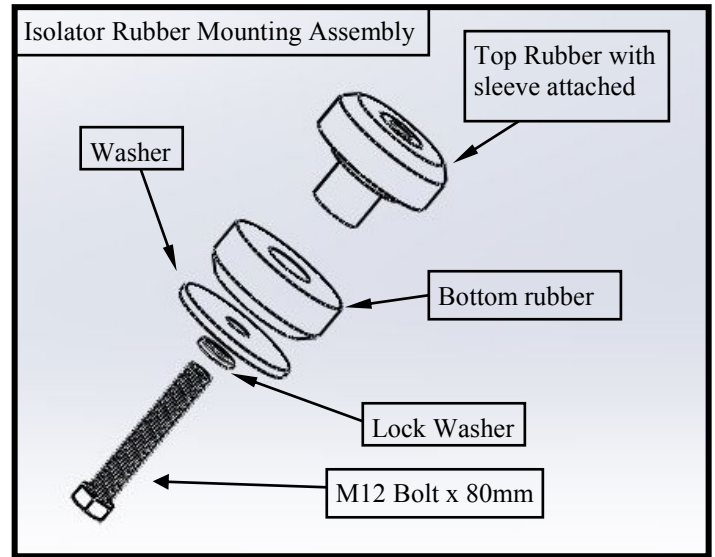

3. Locate and remove on each side of the vehicles rocker panel a set of round plastic plugs. Install (4) M8 U-Nuts (Item 14) to both driver and passenger rocker panel. (Figure 1) Hint: Not all Plugs will need to be removed, determine by looking at the step bars mounting locations, lengths to determine the distances.
4. Locate on each side of the vehicle, the rocker panel pinch weld and insert M8 U-Nuts directly below previously installed rocker panels U-Nuts. If the vehicle is equipped with diesel, position 1 on the passenger side towards the front will need the M8 U-Nut placed with the nut pointing down. (Figure 1 & 2) Hint: Some vehicles may not need a U-Nuts installed, some vehicles already have existing welded M8 nuts attached to the pinch weld.

5. Proceed to install brackets loosely. Please follow (Figure 2 & 3) since bracket placement is critical for proper fitment. For hardware please review (Figure 4) illustrations.

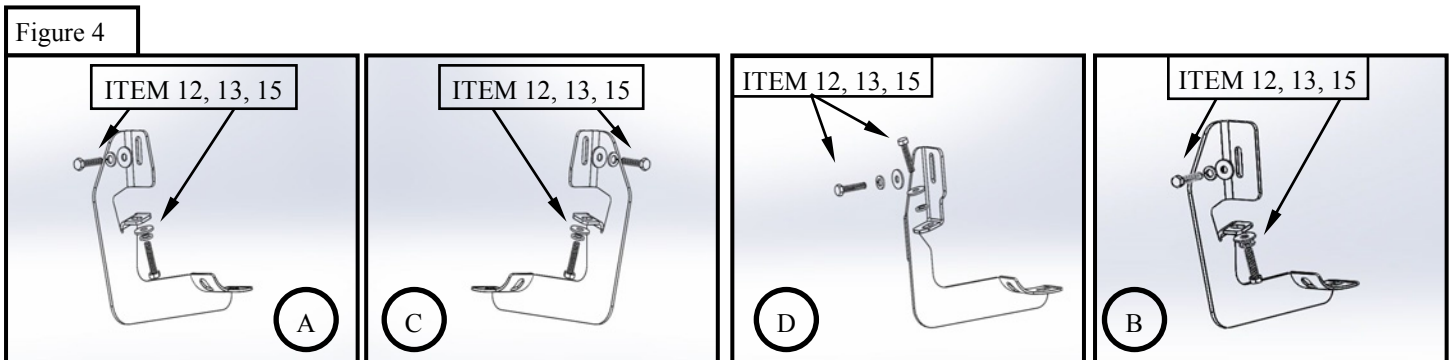
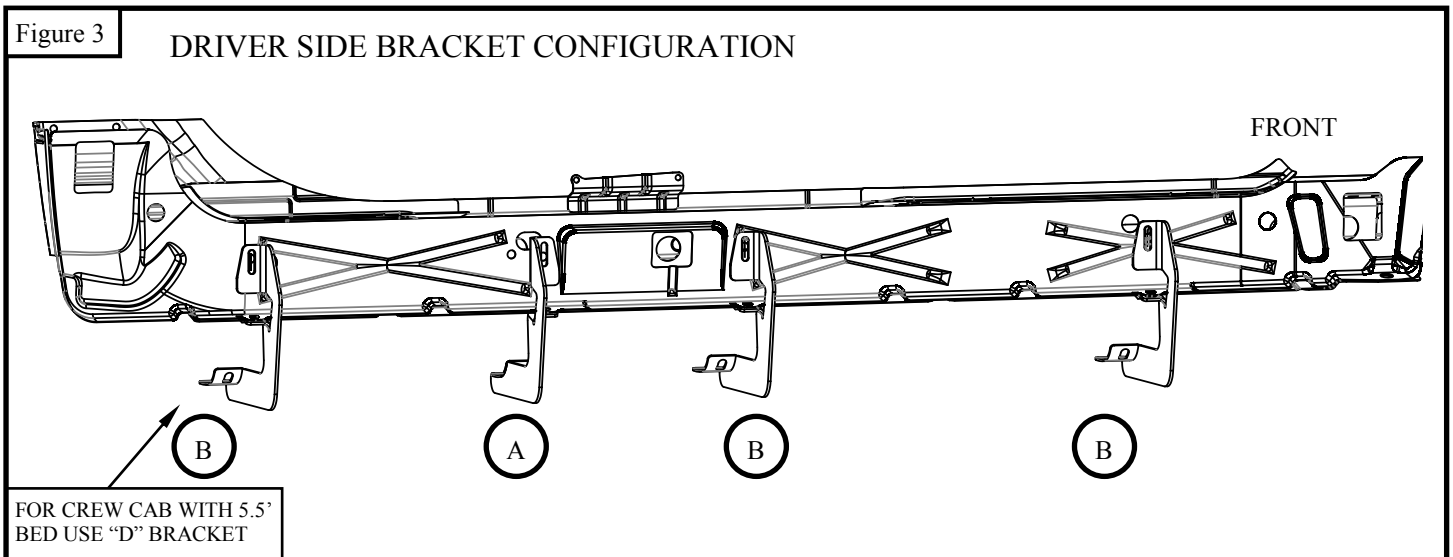
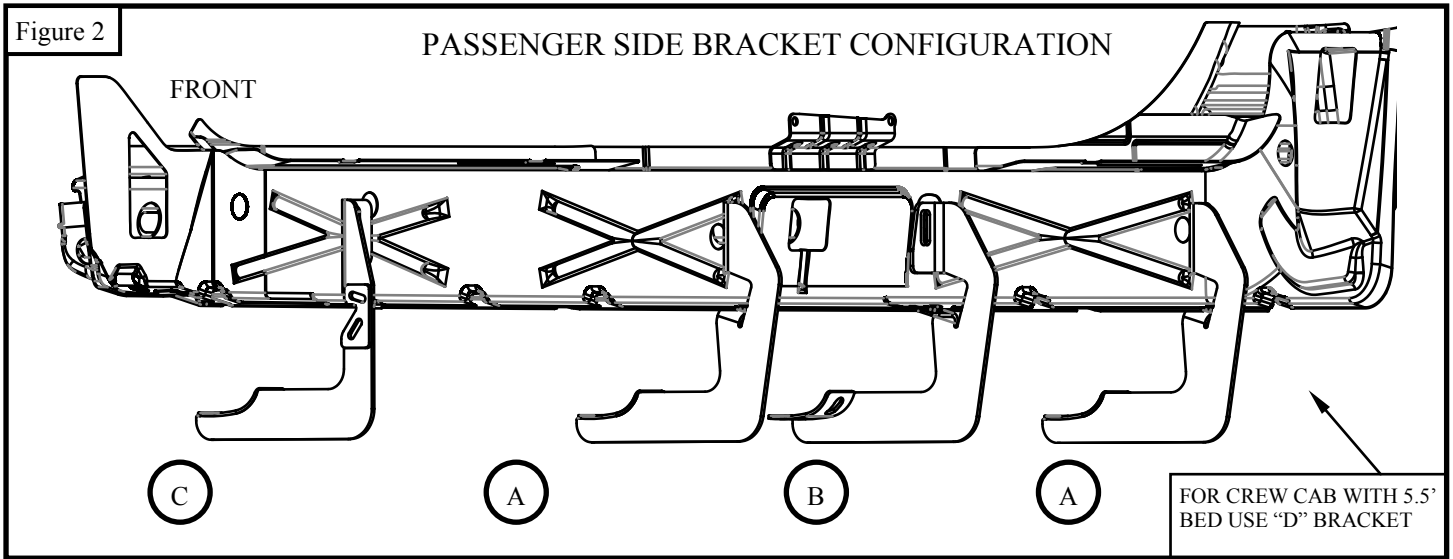

6. For Crew Cab vehicles with 5.5ft. bed please skip to step 9.

7. On each side of the vehicle, directly behind the cab, underneath the bed locate the beam that mounts the bed to the frame. There will be 2 pre-existing bolts. Remove these two bolts and install the Isolator mounting brackets to their respective side (Item 7&9). Hint: Re-use M12 factory bolt. (Figure 5 & 6)

8. Locate the Rubber Isolator Mounting Assembly (Item 11) , along with the Isolator brackets (Item 8 & 10) and install them respectively to each side of the vehicle, to the previously installed Isolator Mounting bracket (Item 7 & 9) (Figure 6)

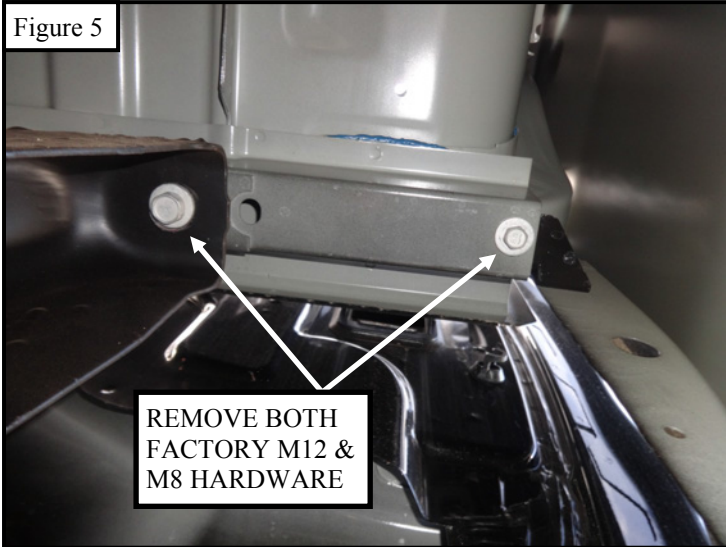
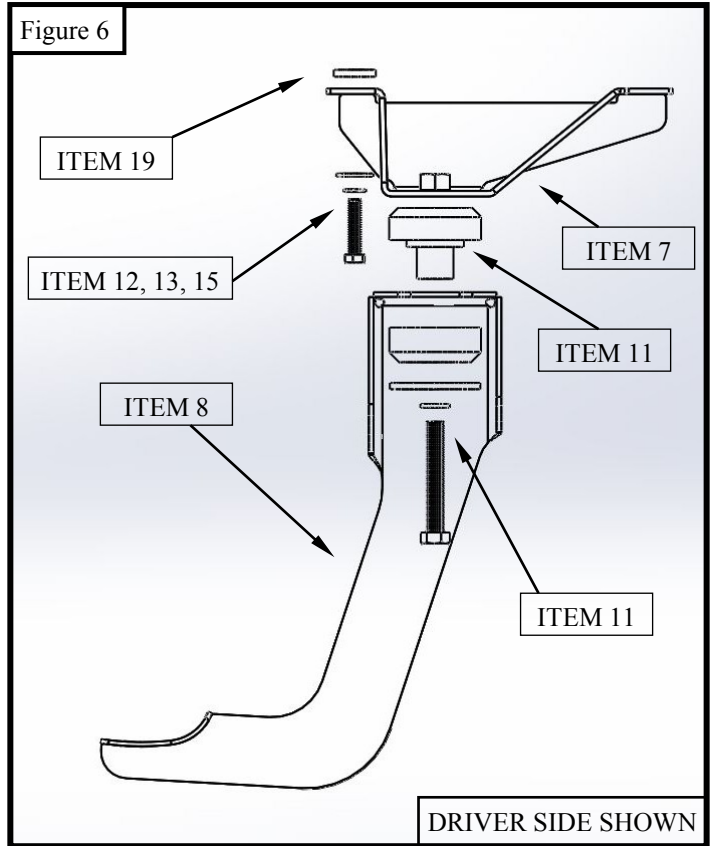

9. Locate Passenger an Driver step bars, and install to the brackets, using (2) M10 Socket Cap Screw (Item 17), (2) M10 Internal Toothed Lock Washers (Item 16) and (2) M10 Flat Washers (Item 18) per mounting bracket cradle.

10. At this time Tighten all M8 hardware to 20ft-lbs., M10 to 25ft-lbs., M12 to 65ft-lbs. For factory hardware, please torque down to vehicle factory specification.



DEF TANK REMOVAL INSTRUCTIONS FOR 11-15 DIESEL MODELS ONLY

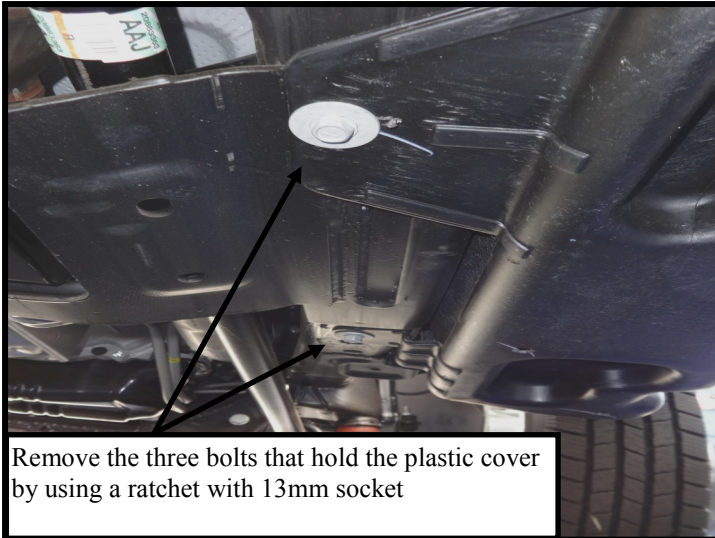

Remove the three bolts that hold the plastic cover by using a ratchet with 13mm socket

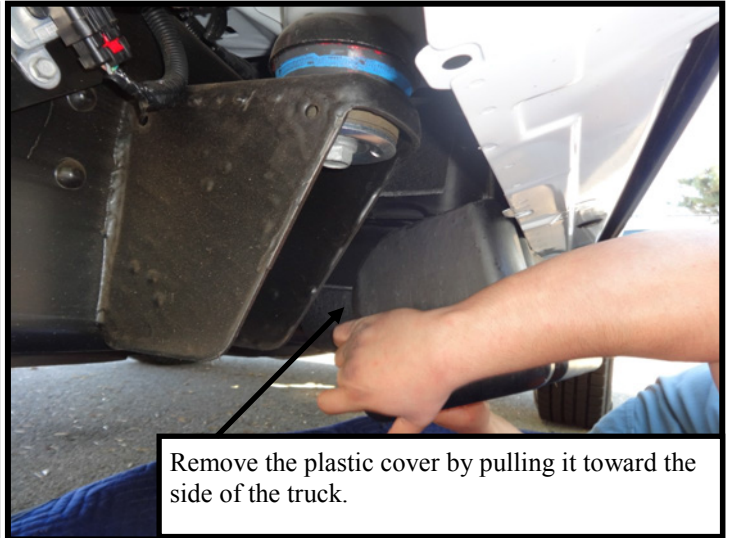

Remove the plastic cover by pulling it toward the side of the truck.

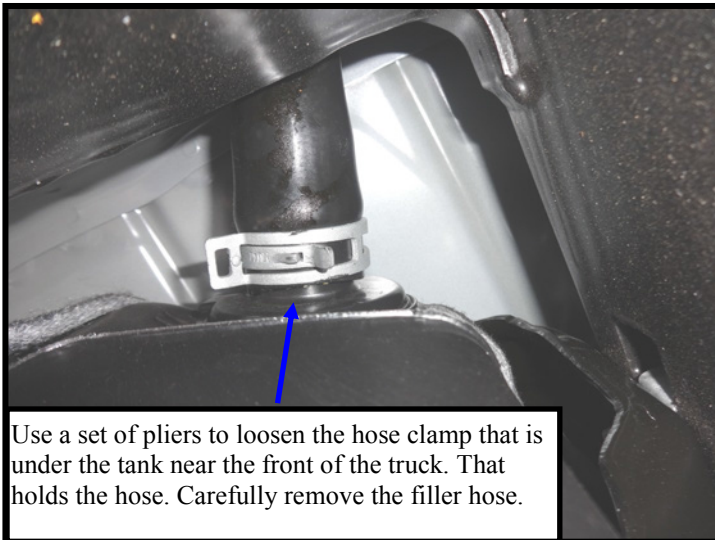

Use a set of pliers to loosen the hose clamp that is under the tank near the front of the truck. That holds the hose. Carefully remove the filler hose.

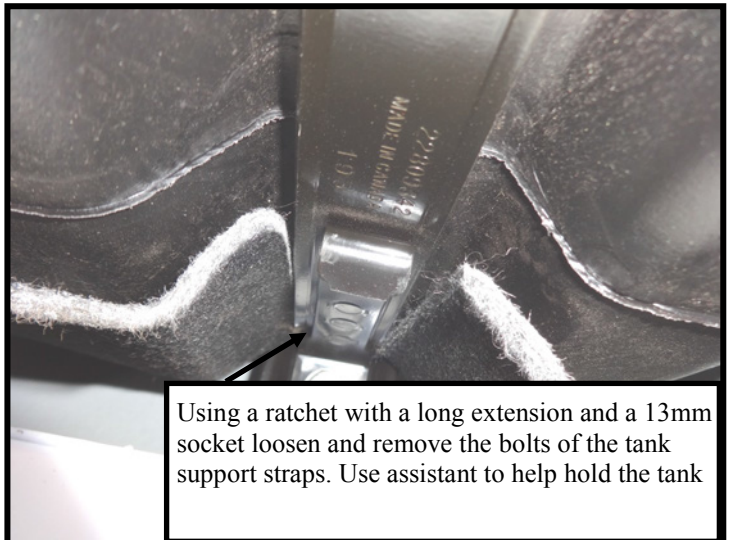

Using a ratchet with a long extension and a 13mm socket loosen and remove the bolts of the tank support straps. Use assistant to help hold the tank

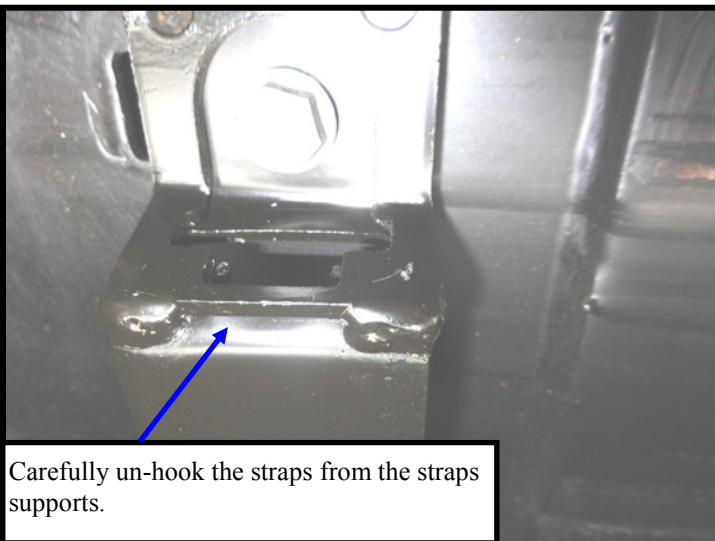

Carefully un-hook the straps from the straps supports.

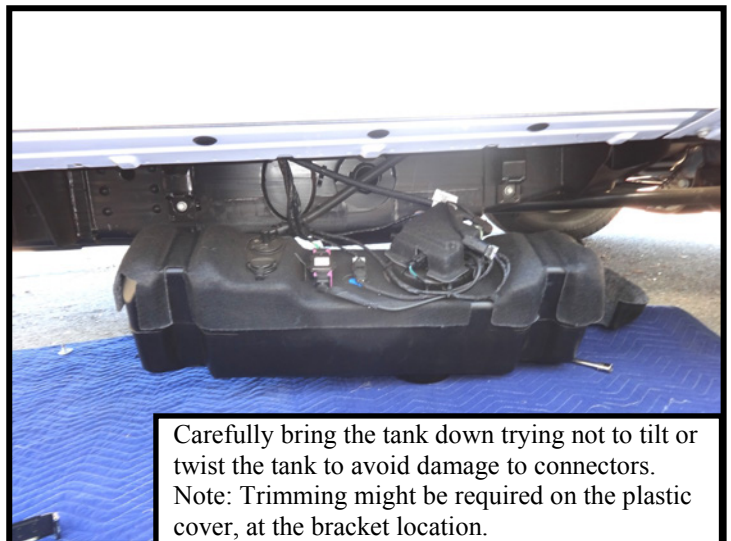

Carefully bring the tank down trying not to tilt or twist the tank to avoid damage to connectors. Note: Trimming might be required on the plastic cover, at the bracket location.