



AUTOMOTIVE PRODUCTS,

INSTALLATION INSTRUCTIONS

PRO TRAX[®] 5 WHEEL-TO-WHEEL

APPLICATION: 2010-2015 Dodge Ram 2500/3500 Crew Cab 8ft Bed

APPLICATION PART #: 21-534330, 21-534335

ITEM	QUANTITY	DESCRIPTION	TOOLS NEEDED
1,2	2	STEP BAR ASSEMBLY (DRIVER/PASSENGER)	16MM SOCKET
3	3	MOUNTING BRACKET DRIVER	18MM SOCKET
4	3	MOUNTING BRACKET PASSENGER	18MM WRENCH
5,6	2	ISOLATOR MOUNTING BRACKET (DRIVER/PASSENGER)	ALLEN KEY
7,8	2	ISOLATOR BRACKET (DRIVER/PASSENGER)	RATCHET
9	2	ISOLATOR KIT	TORQUE WRENCH
10	16	M10 BUTTON HEAD BOLT (BLACK ZINC)	1/2" DRILL BIT
11	16	M10 INTERNAL TOOTHED LOCK WASHER (BLACK ZINC)	DRILL
12	16	M10 FLAT WASHER (BLACK ZINC)	
13	12	M10 FLAT WASHER (YELLOW ZINC)	
14	12	M10 HEX HEAD BOLT (YELLOW ZINC)	
15	12	M10 LOCK WASHER (YELLOW ZINC)	
16	7	M10 RIV CERTS (YELLOW ZINC)	
17	10	M12 FLAT WASHER (YELLOW ZINC)	
18	8	M12 HEX NUT (YELLOW ZINC)	
19	2	M12 HEX HEAD BOLT (YELLOW ZINC)	
20	8	M12 LOCK WASHER (YELLOW ZINC)	
21	6	BOLT PLATE (YELLOW ZINC)	
22	6	M12 PLASTIC RETAINER	

ANTI-SEIZE LUBRICANT MUST BE USED ON ALL STAINLESS STEEL FASTENERS TO PREVENT THREAD DAMAGE AND GALLING

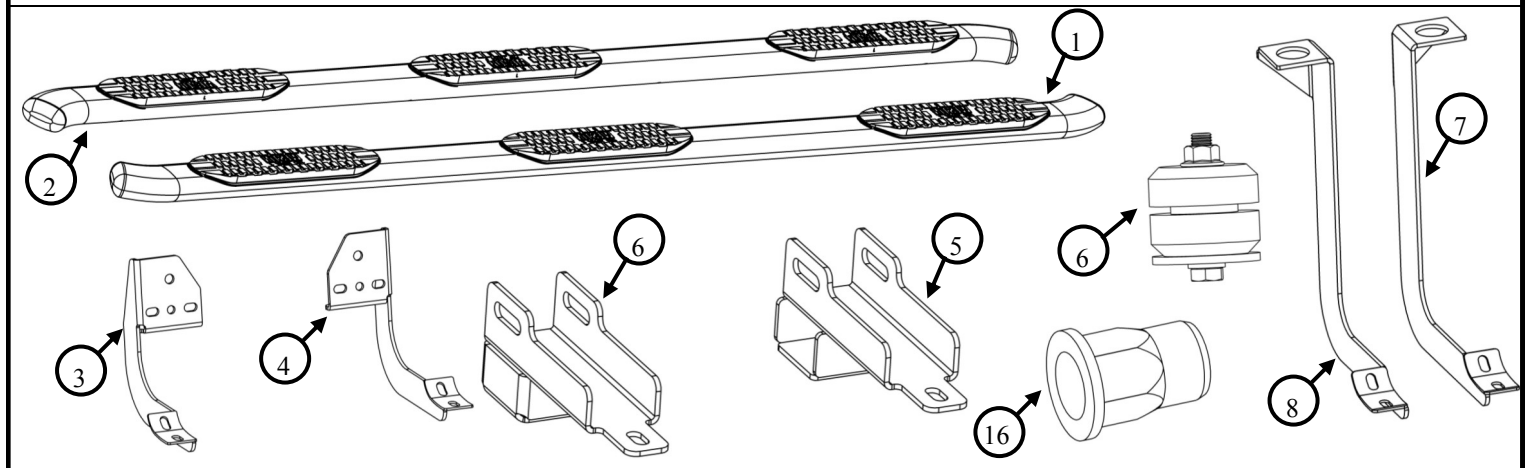

PROCEDURE

1. Remove contents from box, verify if all parts listed are present and free from damage.
Carefully read and understand all instructions before attempting installation.
Failure to identify damage before installation could lead to a rejection of any claim.
2. Starting from either Passenger or Drivers side Rocker Panel, remove the tape that covers the slot, that is located above the 2 hexagon holes. (A total of 3 taped slots per side should be removed). **See Fig. 1 & 2.**
3. Place bolt plate onto the slotted hole (Item 21) as well as the M10 hex riv-cert (Item 16) onto the hexagon hole. (Before inserting stud/ nut plate onto the slot place a square M12 Plastic Retainer (Item 22) on the stud portion of the plate to prevent the plate from falling in the slot, as shown in picture below). **See Fig. 3 & 4.**

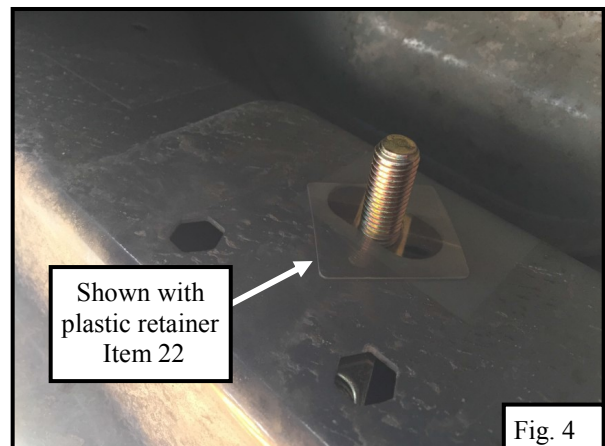
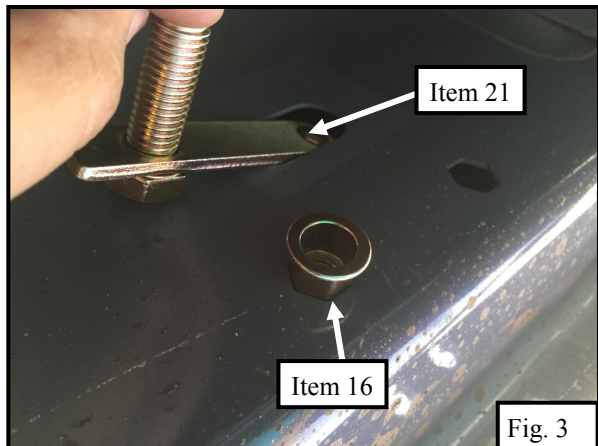
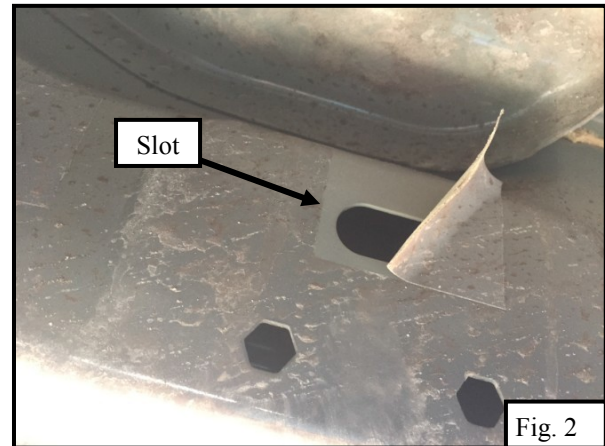
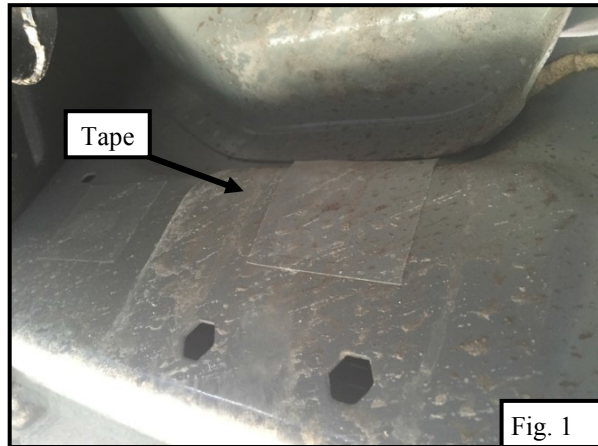

4. In order to properly mount the M10 riv-cert (Item 16) to the rocker panel, place the bracket (Item 3 or 4) tighten stud first then place washer with M10 bolt in the riv-cert and tighten. The riv-cert will expand and lock inside the rocker panel. **See Fig. 5.**
5. Remove the M10 bolt and leave the top hardware in place loosely so that the stud can be moved.
6. Slide bracket slot to the M10 riv-cert and mount using (1) M10 Bolt, lock washer and flat washer. (Items 13,14,15)
7. Remove the nut from the stud on the top of the bracket and turn the stud until the nut on the bottom aligns with the hexagon hole and the slot on the bracket. Using the same hardware as mentioned in step 6 loosely secure the bracket to the rocker panel. Using (1) M12 flat washer, (1) M12 hex nut, and (1) M12 lock washer finish loosely securing mounting brackets. Repeat installation steps to install all of the 6 mounting brackets. **Refer to Bracket Hardware Exploded View.**

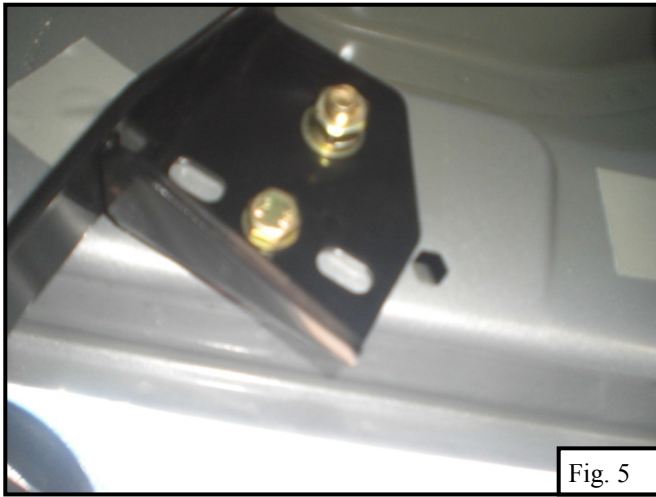
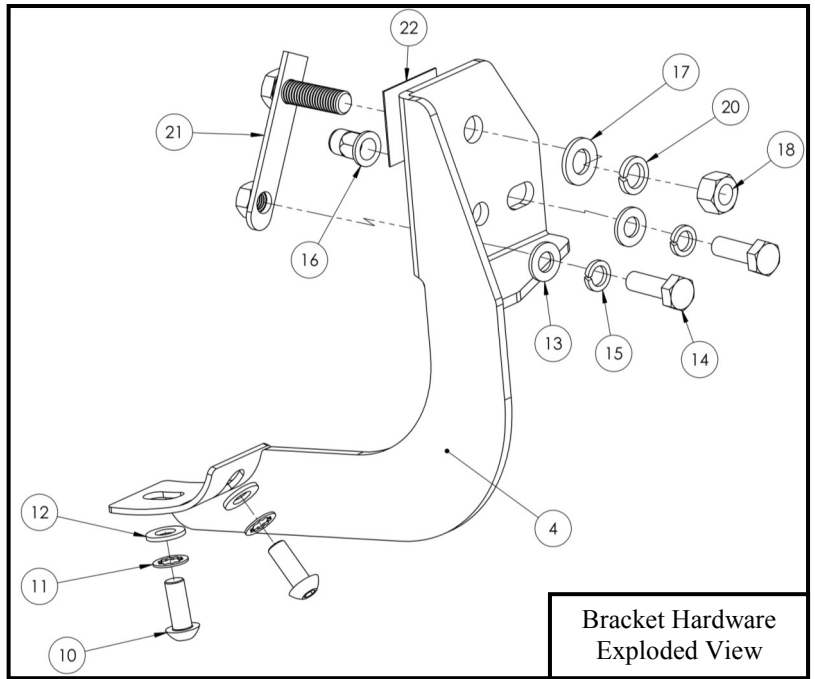

Fig. 5



Bracket Hardware
Exploded View

8. Locate the Isolator Mounting Bracket (Item 5 or 6) and start on either the passenger or driver and repeat installation for other side. Move to the rear of the rocker panel and locate location of factory bolt. **See Fig. 6.**
9. Remove the factory bolt and secure the Isolator Mounting Bracket using the factory bolt. Locate the slot in the Isolator Mounting Bracket and using a 1/2" drill bit, drill a hole through the bed channel. Remove metal debris. Factory bolt will be used for installation. **See Fig. 7.**

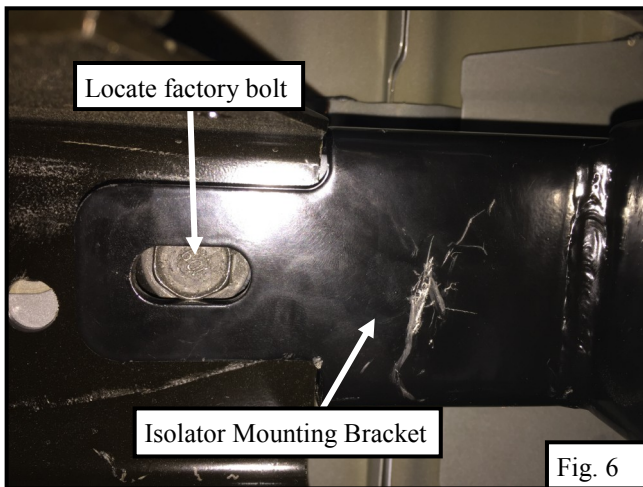

Fig. 6

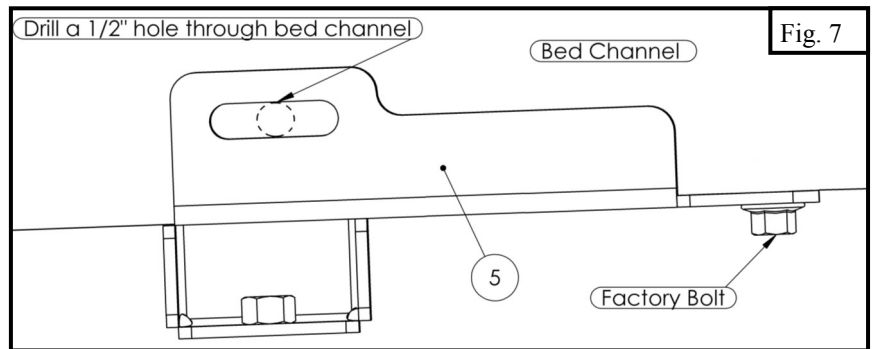
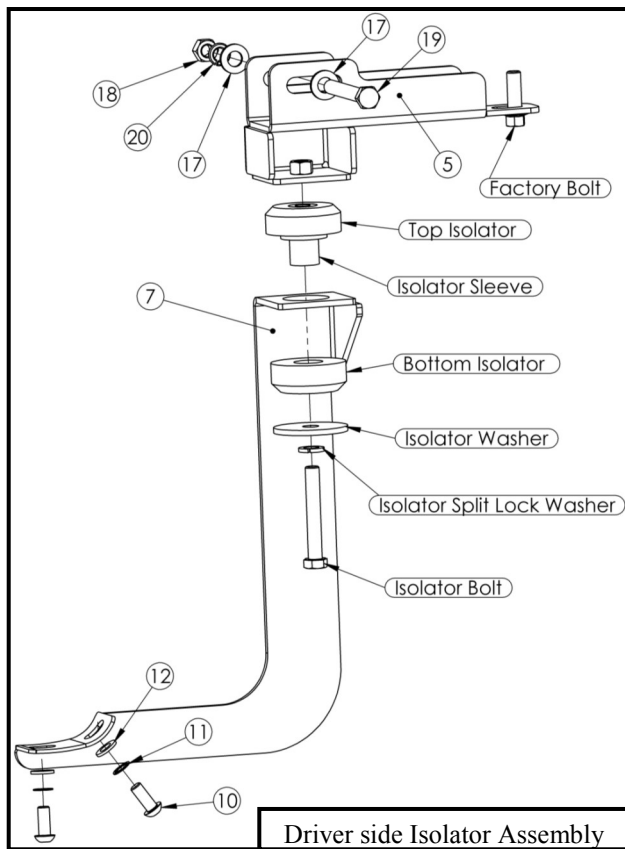

Fig. 7

10. Assemble the Isolator Kit (Item 9), Isolator Mounting Bracket (Item 5), and Isolator Bracket (Item 7). Loosely install the Isolator Mounting Bracket onto bed channel using (1) M12 hex head bolt, (2) M12 flat washer, (1) M12 hex nut, (1) M12 lock washer, and the factory bolt. **See Isolator Assembly.**
11. Take the Driver Step Bar Assembly (Item 1) and align it with the mounting holes in the brackets. Loosely install the step bar with the brackets using the black zinc M10 hardware (Items 10, 11, 12). Repeat for passenger side.
12. Align and adjust step bars as necessary. Tighten and torque all M10 hardware to 30 ft-lbs and M12 hardware to 65 ft-lbs.



CARE INSTRUCTIONS

- REGULAR WAXING IS RECOMMENDED. DO NOT USE ANY TYPE OF POLISH OR WAX THAT MAY CONTAIN ABRASIVES.
- STAINLESS STEEL PRODUCTS CAN BE CLEANED WITH MILD SOAP AND WATER. STAINLESS STEEL POLISH SHOULD BE USED TO POLISH SMALL SCRATCHES.
- GLOSS BLACK FINISHES SHOULD BE CLEANED WITH MILD SOAP AND WATER.



When it comes to quality side steps and nerf bars, Westin is the brand you can depend on.