



# INSTALLATION INSTRUCTIONS

## PROTRAXX 5 OVAL WTW STEP BARS

### APPLICATION:

1999-2016 Ford F-Series Super Duty Super/Crew Cab 250/350/450/550 8' Bed Excludes Dually

### PART NUMBER:

21-534510, 21-534515, 21-534230, 21-534235

AUTOMOTIVE PRODUCTS,

ITEM	QUANTITY	DESCRIPTION	TOOLS NEEDED
1	2	STEP BAR ASSEMBLY	16MM SOCKET
2,3	2	BED MOUNT BOTTOM BRACKET, DRIVER(2) AND PASSENGER(3)	18MM SOCKET
4	2	FRONT SPACER PLATE	16MM WRENCH
5,6	2	BED MOUNT TOP BRACKET, DRIVER(5) AND PASSENGER(6)	18MM WRENCH
7	2	ISOLATOR KIT	RATCHET
8	6	MOUNTING BRACKET	TORQUE WRENCH
9	1	LONG M12 BOLT PLATE, PASSENGER	DRILL
10	1	M12 BOLT PLATE, DRIVER	
11	14	M10 HEX NUTS (YELLOW ZINC)	
12	38	M10 FLAT WASHERS (YELLOW ZINC)	
13	10	M10 U-NUT CLIP (YELLOW ZINC)	
14	24	M10 SPLIT LOCK WASHERS (YELLOW ZINC)	
15	22	SHORT M10 HEX HEAD CAP SCREWS (YELLOW ZINC)	
16	2	LONG M10 HEX HEAD CAP SCREWS (YELLOW ZINC)	
17	2	M12 HEX NUTS (YELLOW ZINC)	
18	2	M12 FLAT WASHERS (YELLOW ZINC)	
19	2	M12 SPLIT LOCK WASHERS (YELLOW ZINC)	
20	16	M10 BUTTON HEAD BOLTS (BLACK ZINC)	
21	16	M10 FLAT WASHERS (BLACK ZINC)	
22	16	M10 INTERNAL TOOTHED LOCK WASHERS (BLACK ZINC)	

**ANTI-SEIZE LUBRICANT MUST BE USED ON ALL STAINLESS STEEL FASTENERS TO PREVENT THREAD DAMAGE AND GALLING**

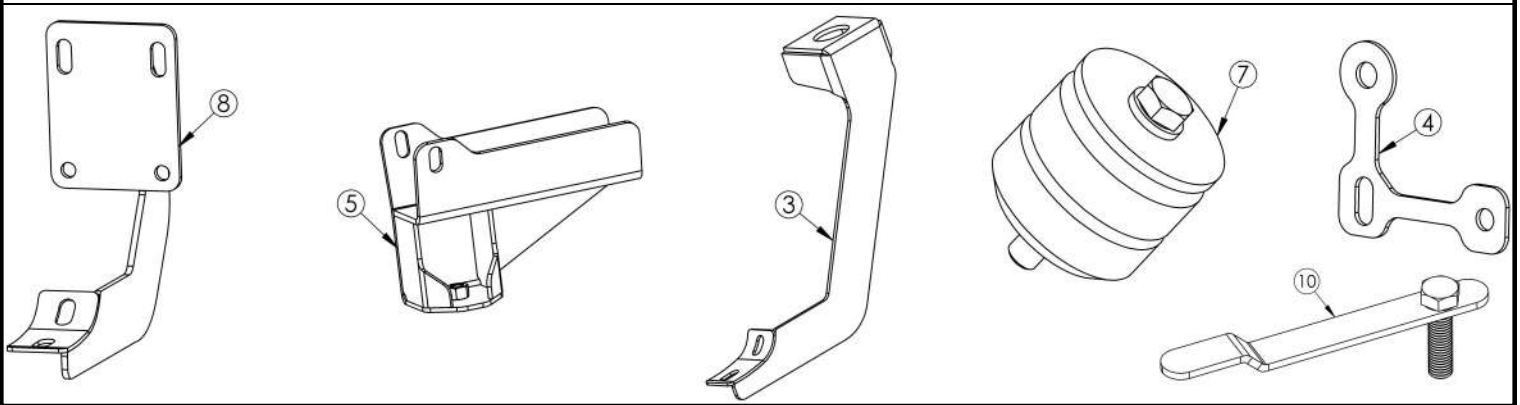

## PROCEDURE

1. Remove contents from box, verify if all parts listed are present and free from damage.

Carefully read and understand all instructions before attempting installation.

**Failure to identify damage before installation could lead to a rejection of any claim.**

2. Starting at the front driver side, find the front driver side mounting location and insert (1) M10 u-nut clip. Loosely secure (1) mounting bracket to the nut clip using (1) M10 hex head bolt, (1) M10 lock washer, and (1) M10 flat washer. Attach the mounting bracket to the existing holes in the pinch weld using (2) M10 hex head bolts, (4) M10 flat washers, (2) M10 lock washers, and (2) M10 hex nuts. **Note:** For 2010 - up model years place (1) front spacer plate in-between the rocker panel and the front mounting bracket before attaching. Do not fully tighten at this time. See **Figures 1, 2, and 3.**

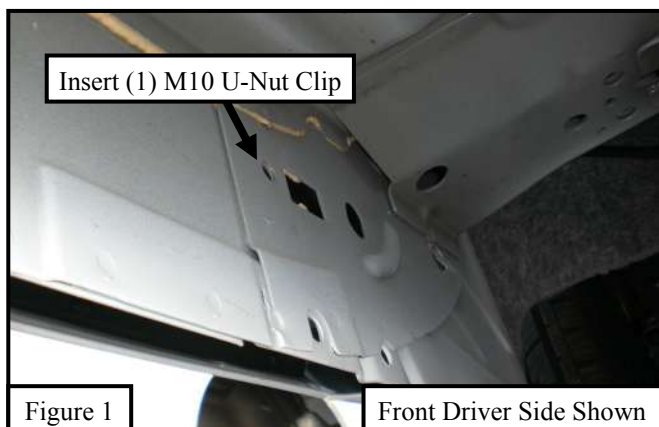

3. Locate the second mounting location on the rocker panel. See **Figure 4**. Insert (2) M10 u-nut clips onto the small circular holes. See **Figure 5**. Attach the mounting bracket to the nut clips using (2) M10 hex head bolts, (2) M10 lock washers, and (2) M10 flat washers. Attach the mounting bracket to the existing holes in the pinch weld using (2) M10 hex head bolts, (4) M10 flat washers, (2) M10 lock washers, and (2) M10 hex nuts. See **Figure 6**. Do not fully tighten at this time. Repeat this step for the rear mounting bracket. Do not fully tighten at this time.



4. At the rear driver side of the vehicle locate a plastic clip that holds wires in place. Remove plastic clip and leave off to the side with wires still attached. **See Figure 7.**
5. Locate (1) M12 bolt plate (Item 10) and insert through opening of bed channel and insert the M12 bolt through the hole. **See Figure 8.**

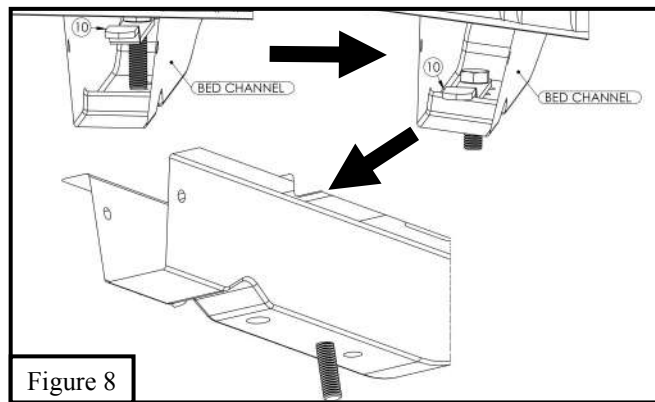

6. Locate (1) step bar assembly and loosely secure it to the previously installed brackets. Loosely install onto brackets using (6) M10 button head bolts, (6) M10 flat washers and (6) M10 internal toothed lock washers.
7. Locate (1) bed mount bottom bracket, (1) bed mount top bracket and (1) isolator kit and assemble together. **See Figure 9.**
8. Align the assembly of the bed mount top bracket, bed mount bottom bracket and the isolator kit to the bed channel and adjust the assembly, by moving it along the bed channel, until two holes in the cradle are aligned with the two holes of the step bar assembly. Then secure assembly to previous installed M12 bolt plate using the provided M12 hardware. **See Figure 10.**
9. Once step bar assembly and isolator assembly are aligned, mark two locations on the bed channel to drill. Remove bed mount bracket assembly off the bed channel and then drill two 7/16" holes on the bed channel. Deburr edges if needed. **See Figure 11**

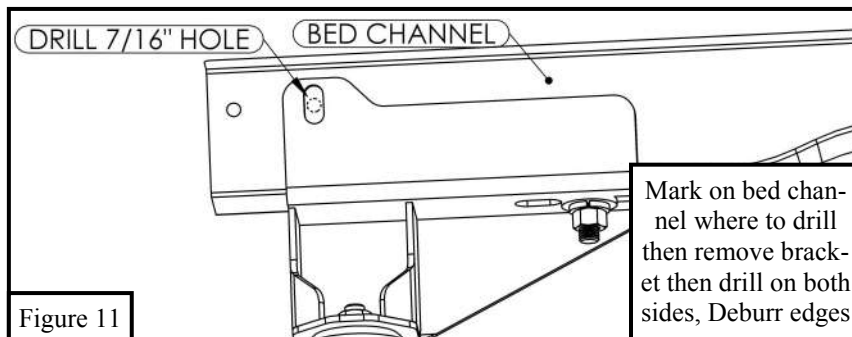
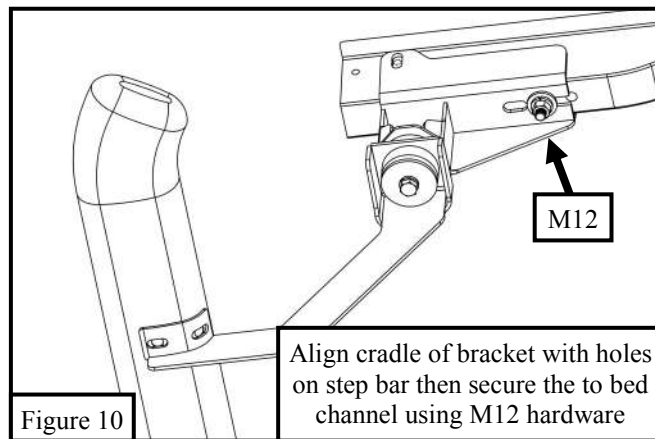
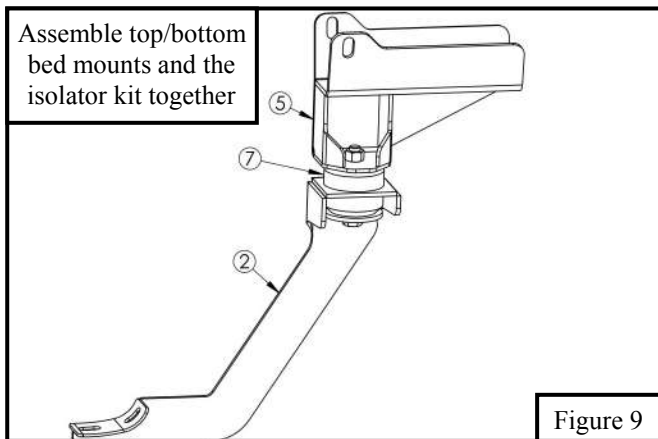

10. Using (1) long M10 hex head cap screw, (1) M10 lock washer, (2) M10 flat washers and the provided M12 hardware loosely secure the top bed mount bracket and its assembly onto the frame channel. **See Figure 12.**
11. Re-attach plastic clip, shown in **Figure 7**, back onto the bed channel.
12. Locate (1) step bar assembly and loosely attach onto previously installed brackets using (8) M10 button head bolts, (8) M10 flat washers and (8) M10 internal toothed lock washers. **See Figure 13.**
13. Repeat steps 2 - 12 for passenger side.
14. Align and adjust brackets and step bars as necessary then torque: M10 hardware 30 - 35 ft-lbs and M12 hardware 60 - 65 ft-lbs.

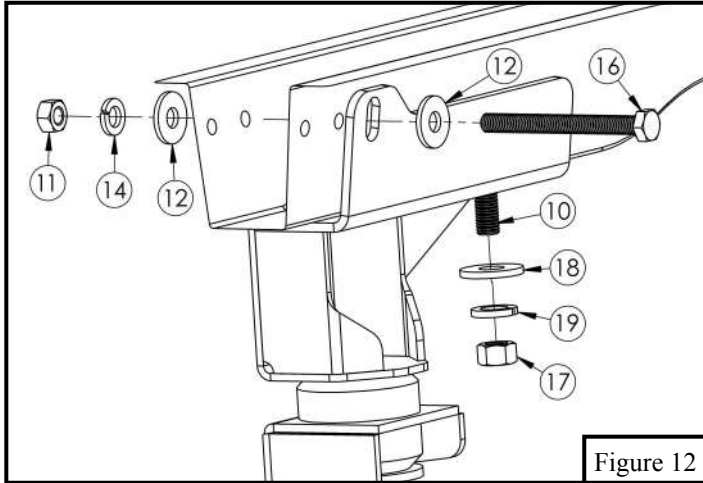

Figure 12

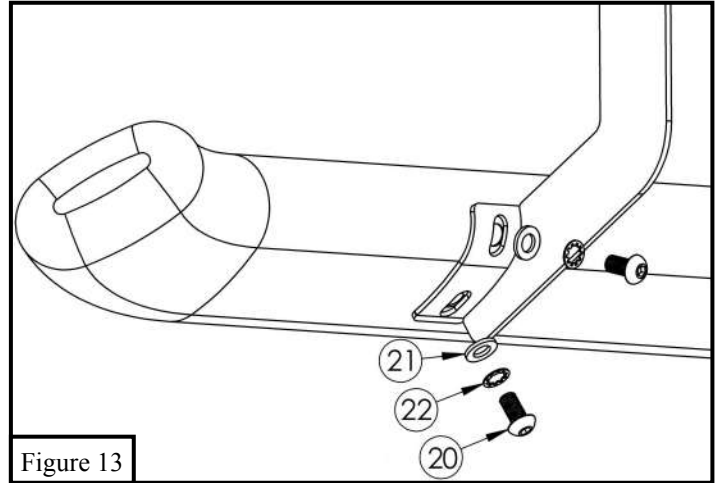

Figure 13



#### CARE INSTRUCTIONS

- REGULAR WAXING IS RECOMMENDED. DO NOT USE ANY TYPE OF POLISH OR WAX THAT MAY CONTAIN ABRASIVES.
- STAINLESS STEEL PRODUCTS CAN BE CLEANED WITH MILD SOAP AND WATER. STAINLESS STEEL POLISH SHOULD BE USED TO POLISH SMALL SCRATCHES.
- GLOSS BLACK FINISHES SHOULD BE CLEANED WITH MILD SOAP AND WATER.



# Westin

SIGNATURE OF QUALITY

AUTOMOTIVE PRODUCTS, INC.



## WARNING



Failure to follow these instructions could lead to death, personal injury, and / or property damage.

### FASTENERS:

All Westin supplied fasteners must be utilized and installed in accordance with the installation instructions and apply torque to the specifications as defined. **DOUBLE CHECK ALL FASTENERS BEFORE INITIAL USE, AND PERIODICALLY IN THE FUTURE TO ENSURE PROPER FUNCTION AND SAFETY.**

### DRILLING:

Most Westin products do not require drilling for installation. If drilling is defined as required, use caution when drilling a vehicle. **FAILURE TO REVIEW AN AREA TO BE DRILLED MAY RESULT IN PERSONAL INJURY AND/OR INJURY TO OTHERS AS WELL AS VEHICLE DAMAGE.**

### EYE PROTECTION:

**ALWAYS WEAR SAFETY GLASSES OR GOGGLES DURING THE INSTALLATION PROCESS TO AVOID PERSONAL INJURY.**

### MAXIMUM TOWING/CARRYING CAPACITY:

The Westin Receiver Hitches will have a visible tow rating label affixed directly on the product. User should never exceed the vehicle manufacturers maximum tow and weight rating regardless of the capacity of the hitch. **FAILURE TO FOLLOW THESE GUIDELINES WILL VOID THE WESTIN WARRANTY AND MAY RESULT IN PERSONAL INJURY AND/OR INJURY TO OTHERS AS WELL AS VEHICLE DAMAGE.**

When it comes to quality side steps and nerf bars, Westin is the brand you can depend on.