



INSTALLATION INSTRUCTIONS

Pro-Traxx 5 WTW

AUTOMOTIVE PRODUCTS,

APPLICATION:

1999-2015 Ford F-250/350 Super Cab 6.75 ft bed
1999-2015 Ford F-250/350 Super Crew 6.75 ft bed

PART NUMBER:

21-534250, 21-534255, 21-534010, 21-534015

CONTENT			
ITEM	QUANTITY	DESCRIPTION	TOOLS NEEDED
1,2	2	STEP BAR ASSEMBLY, DRIVER AND PASSENGER	17MM SOCKET
3	6	MOUNTING BRACKET	17MM WRENCH
4	2	FRONT SPACER PLATE	ALLEN KEY (INLCUDED)
5	24	M10 HEX CAP SCREW (YELLOW ZINC)	
6	36	M10 FLAT WASHER (YELLOW ZINC)	RATCHET
7	24	M10 SPRING LOCK WASHER (YELLOW ZINC)	TORQUE WRENCH
8	12	M10 HEX NUT (YELLOW ZINC)	
9	12	M10 NUT CLIPS (YELLOW ZINC)	
10	12	M10 BUTTON HEAD SOCKET CAP SCREW (BLACK ZINC)	
11	12	M10 INTERNAL TOOTHED LOCK WASHER (BLACK ZINC)	
12	12	M10 FLAT WASHER (BLACK ZINC)	

ANTI-SEIZE LUBRICANT MUST BE USED ON ALL STAINLESS STEEL FASTENERS TO PREVENT THREAD DAMAGE AND GALLING

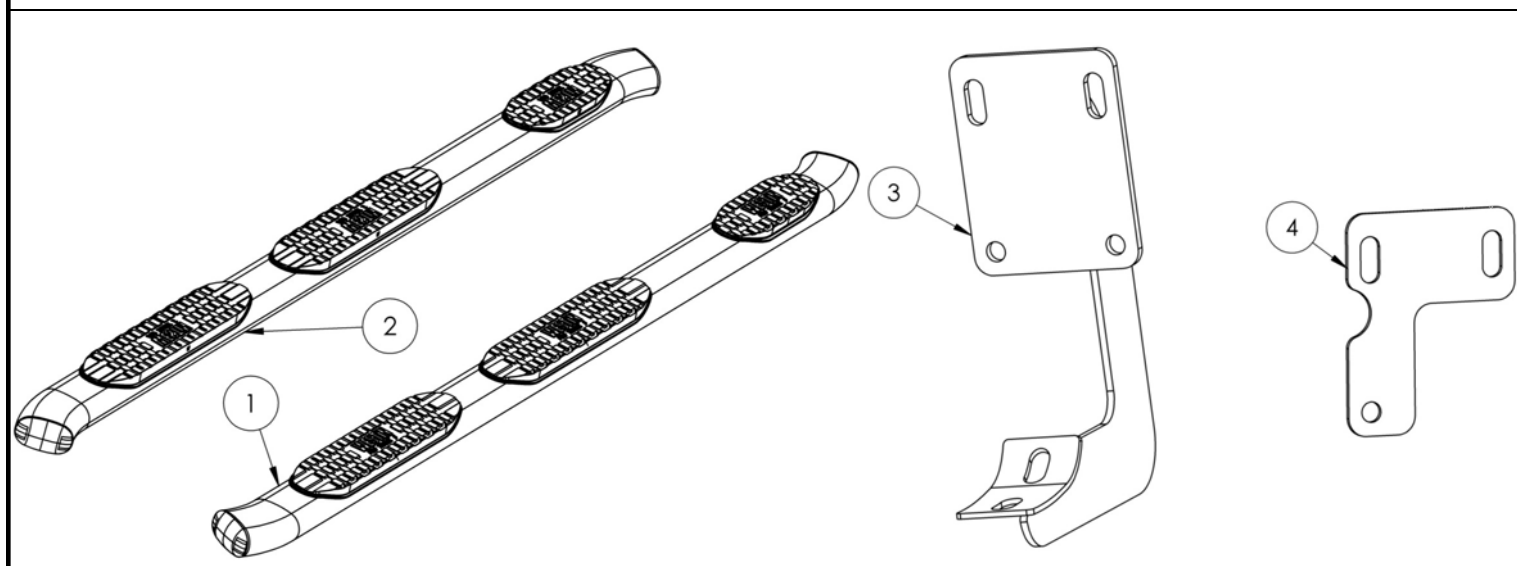

PROCEDURE

1. Remove contents from box, verify if all parts listed are present and free from damage.
Carefully read and understand all instructions before attempting installation.
Failure to identify damage before installation could lead to a rejection of any claim.

1. Starting at the drivers side, locate the front mounting point on the rocker panel. NOTE: *On some vehicles the mounting holes do not line up from the factory if this is the case drill out the holes using a 7/16" drill bit. (Fig. 1).* Insert (1) M10 nut clip (Item 9) onto the small circular hole (Fig. 2) and attach (1) mounting bracket (item 3) to the nut clip using (1) M10 hex cap screw (Item 5), (1) M10 spring lock washer (Item 7), and (1) M10 flat washer (Item 6). Attach the mounting bracket to the existing holes in the pinch weld using (2) M10 hex cap screw (Item 5), (4) M10 flat washers (Item 6), (2) M10 spring lock washers (Item 7), and (2) M10 hex nuts (Item 8) (Fig. 3). Note: *for 2010– up model years place (1) front mounting bracket spacer (item 11) in between the rocker panel and the front mounting bracket before attaching (Fig. 4).* **Do not fully tighten at this time.**

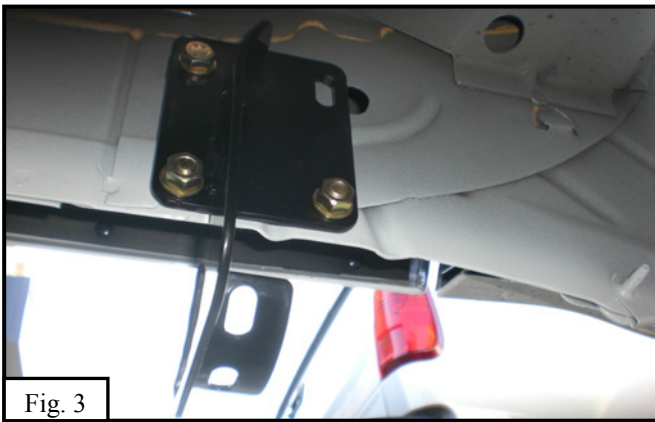
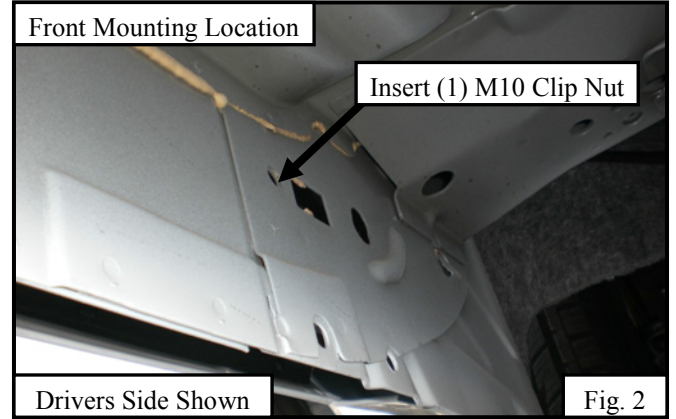

2. Locate the second mounting point on the rocker panel (Fig. 5), insert (2) M10 clip nuts (Item 9) onto the small circular holes (Fig. 6). Attach the mounting bracket to the existing holes in the pinch weld using (2) M10 hex cap screws (Item 5), (2) M10 spring lock washers (Item 7), and (2) M10 flat washer (Item 6). Attach the mounting bracket to the existing holes in the pinch weld using (2) M10 hex cap screw (Item 5), (4) M10 flat washer (Item 6), (2) M10 spring lock washer (Item 7), and (2) M10 hex nut (Item 8). (Fig. 7) **Do not fully tighten at this time.**
3. Repeat this step for the rear mounting bracket. **Do not fully tighten at this time.**

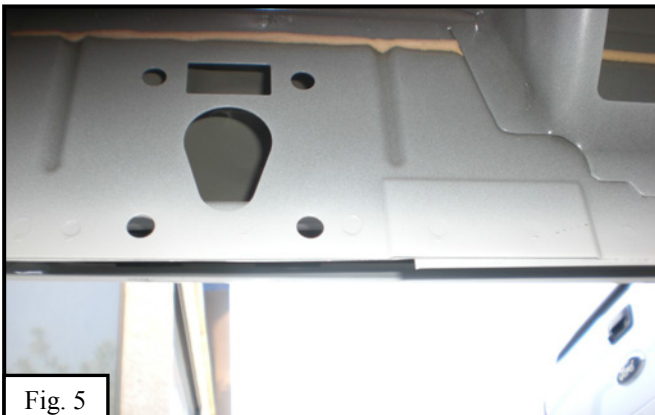

4. Take the drivers side step bar (Item 1) and attach it to the mounting cradles using (6) M10 button head socket cap screw (Item 10), (6) M10 internal toothed lock washer (Item 11), and (6) M10 flat washer (Item 12). **(Fig. 8) Do not fully tighten at this time.**
5. Repeat steps 2-5 for passenger side.
6. Align and adjust step bars as needed then fully tighten all hardware at this time. **Torque all M10 fasteners to 30-35 ft lbs.**

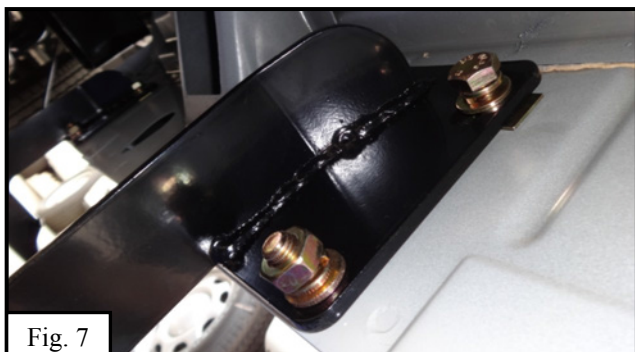
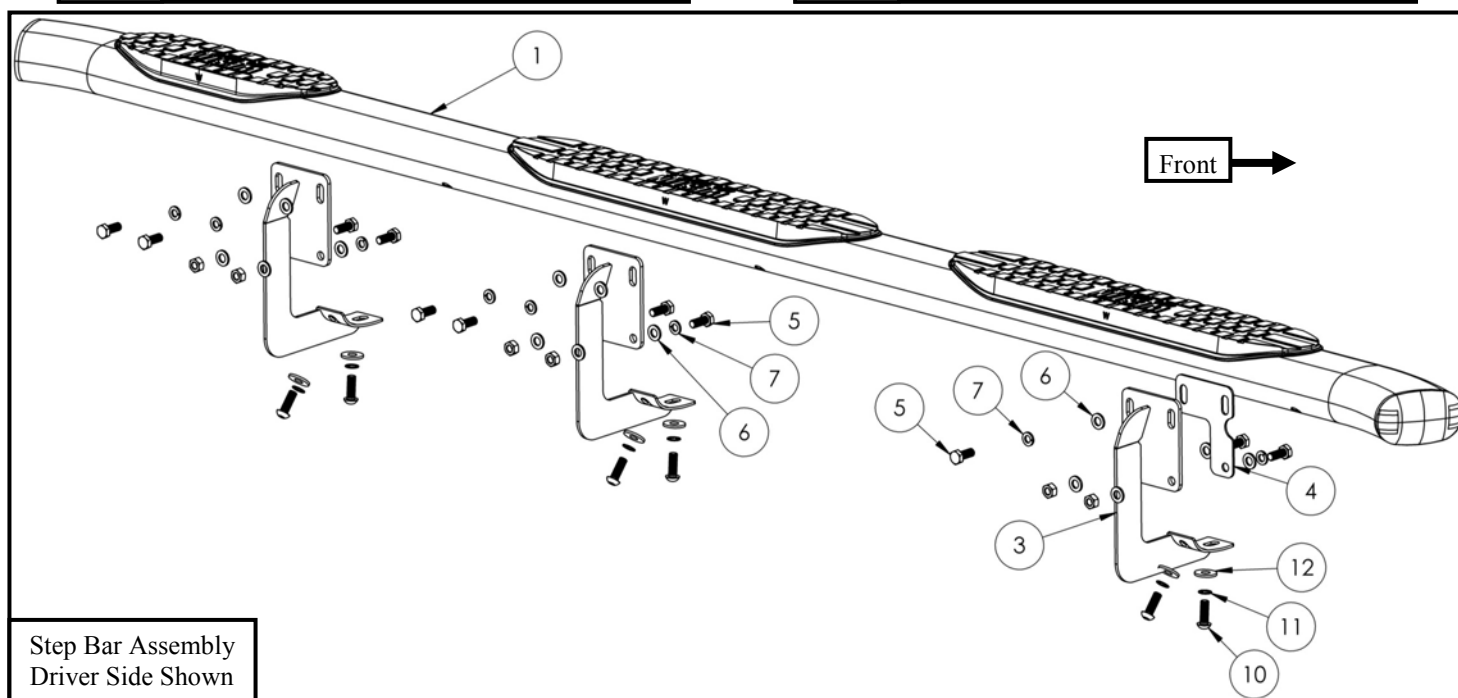

Fig. 7



Fig. 8



Step Bar Assembly
Driver Side Shown



INSTALLATION COMPLETE

CARE INSTRUCTIONS

- REGULAR WAXING IS RECOMMENDED. DO NOT USE ANY TYPE OF POLISH OR WAX THAT MAY CONTAIN ABRASIVES.
- STAINLESS STEEL PRODUCTS CAN BE CLEANED WITH MILD SOAP AND WATER. STAINLESS STEEL POLISH SHOULD BE USED TO POLISH SMALL SCRATCHES.
- GLOSS BLACK FINISHES SHOULD BE CLEANED WITH MILD SOAP AND WATER.

Westin

SIGNATURE OF QUALITY

AUTOMOTIVE PRODUCTS, INC.



WARNING



Failure to follow these instructions could lead to death, personal injury, and / or property damage.

FASTENERS:

All Westin supplied fasteners must be utilized and installed in accordance with the installation instructions and apply torque to the specifications as defined. **DOUBLE CHECK ALL FASTENERS BEFORE INITIAL USE, AND PERIODICALLY IN THE FUTURE TO ENSURE PROPER FUNCTION AND SAFETY.**

DRILLING:

Most Westin products do not require drilling for installation. If drilling is defined as required, use caution when drilling a vehicle. **FAILURE TO REVIEW AN AREA TO BE DRILLED MAY RESULT IN PERSONAL INJURY AND/OR INJURY TO OTHERS AS WELL AS VEHICLE DAMAGE.**

EYE PROTECTION:

ALWAYS WEAR SAFETY GLASSES OR GOGGLES DURING THE INSTALLATION PROCESS TO AVOID PERSONAL INJURY.

MAXIMUM TOWING/CARRYING CAPACITY:

The Westin Receiver Hitches will have a visible tow rating label affixed directly on the product. User should never exceed the vehicle manufacturers maximum tow and weight rating regardless of the capacity of the hitch. **FAILURE TO FOLLOW THESE GUIDELINES WILL VOID THE WESTIN WARRANTY AND MAY RESULT IN PERSONAL INJURY AND/OR INJURY TO OTHERS AS WELL AS VEHICLE DAMAGE.**

Accept no compromises, choose only quality side steps and nerf bars.