



AUTOMOTIVE PRODUCTS,

INSTALLATION INSTRUCTIONS

PRO TRAXX[®] 5 WHEEL-TO-WHEEL

APPLICATION:

2009-2014 Ford F-150 Super Cab 6.5 ft Bed

PART NUMBER: 21-533510, 21-533515

ITEM	QUANTITY	DESCRIPTION	TOOLS NEEDED
1,2	2	STEP BAR ASSEMBLY DRIVER/PASSENGER	TORQUE WRENCH
3,4	4	MOUNTING BRACKET DRIVER/PASSENGER	RATCHET
5,6	2	REAR MOUNTING BRACKET DRIVER/PASSENGER	HEX KEY
7	8	M8 EXTRUDED U-NUT(YELLOW ZINC)	13MM SOCKET
8	18	M8 HEX CAP SCREW (YELLOW ZINC)	16MM SOCKET
9	8	M8 SMALL FLAT WASHER (YELLOW ZINC)	13MM WRENCH
10	20	M8 LARGE FLAT WASHER (YELLOW ZINC)	16MM WRENCH
11	18	M8 SPRING LOCK WASHER (YELLOW ZINC)	DRILL
12	10	M8 HEX NUT (YELLOW ZINC)	3/8" DRILL BIT
13	2	M10 HEX CAP SCREW (YELLOW ZINC)	
14	4	M10 FLAT WASHER (YELLOW ZINC)	
15	2	M10 SPRING LOCK WASHER (YELLOW ZINC)	
16	2	M10 HEX NUT (YELLOW ZINC)	
17	12	M10 BUTTON HEAD SOCKET CAP SCREW (BLACK ZINC)	
18	12	M10 FLAT WASHER (BLACK ZINC)	
19	12	M10 INTERNAL TOOTH LOCK WASHER (BLACK ZINC)	

ANTI-SEIZE LUBRICANT MUST BE USED ON ALL STAINLESS STEEL FASTENERS TO PREVENT THREAD DAMAGE AND GALLING

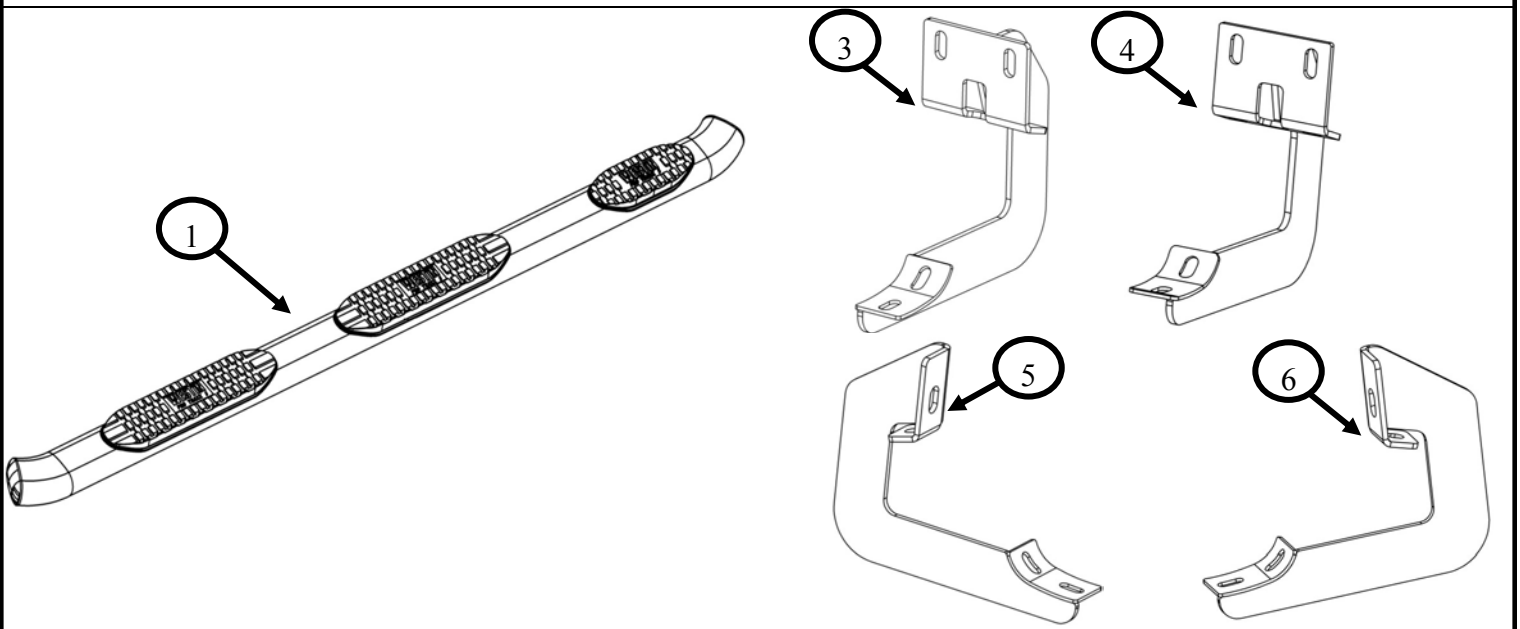

PROCEDURE

1. Remove contents from box, verify if all parts listed are present and free from damage.
Carefully read and understand all instructions before attempting installation.
Failure to identify damage before installation could lead to a rejection of any claim.
2. Start installation on the driver's side. On the rocker panel locate and remove the tape covering the holes. Insert (4) M8 extruded u-nut into the two holes in rocker panel. **See Fig. 1.** Locate the (2) Mounting Driver Bracket (Item 3) and loosely install it to the previously installed M8 extruded u-nuts, using (2) M8 hex cap screw, (2) M8 spring lock washer, and (2) M8 large flat washer. Loosely install the Mounting Driver Bracket to the pinch weld using (2) M8 hex cap screw, (2) M8 large flat washer, (2) M8 small flat washer, (2) M8 hex nut, and (2) M8 spring lock washer. Put the large flat washer on the outside of the pinch weld and the small flat washer on the inside of the pinch weld. Repeat for the other mounting driver bracket. **See Fig. 2 & Driver Mounting Bracket Assembly.** (Note: The mounting cradles face the rear of the vehicle.)
3. Moving to the rear of the rocker panel, locate the factory hole. **See Fig. 3.** Locate Driver Rear Mounting Bracket (Item 5). Using the supplied M10 hardware, loosely install the bracket to the rocker panel factory hole. **See Fig. 4.** Align the bracket with the pinch weld and drill a hole through the pinch weld using a 3/8" drill bit. Remove any metal debris. Loosely secure the bracket to the pinch weld using (1) M8 hex cap screw, (1) M8 spring lock washer, (2) M8 large flat washer, and (1) M8 hex nut. **See Driver Rear Mounting Bracket Assembly.**
4. Locate the Driver Step Bar Assembly (Item 1) and align it with the brackets. **See Fig. 5.**
5. Loosely install the Driver Step Bar Assembly using supplied M10 hardware (black zinc/stainless steel). **See Fig. 6.**

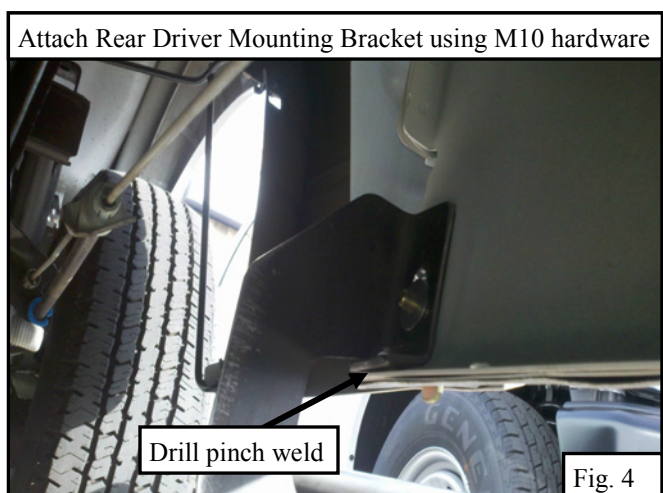
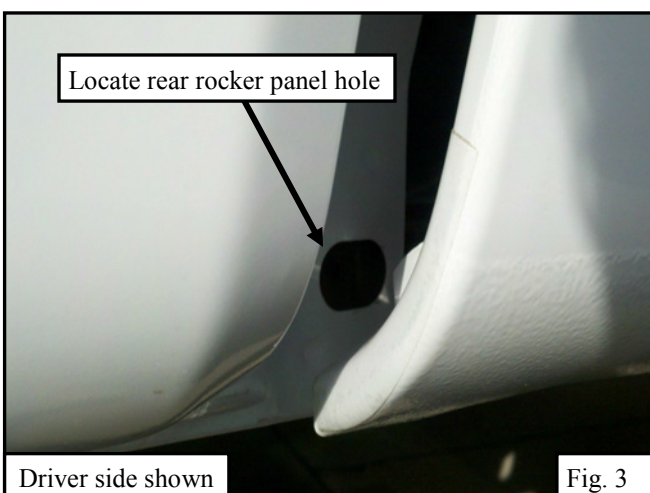
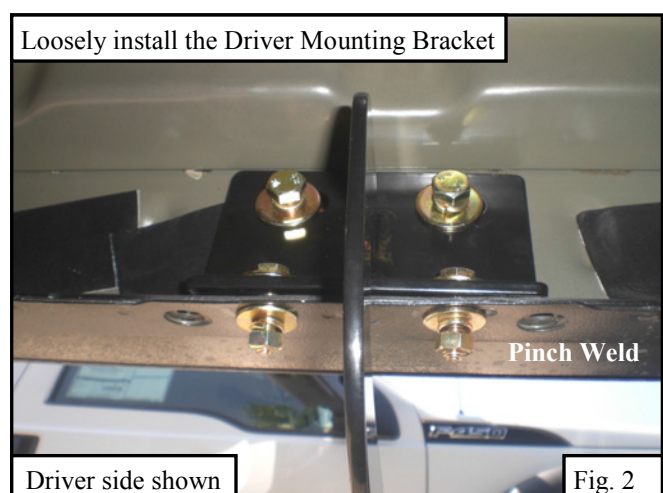
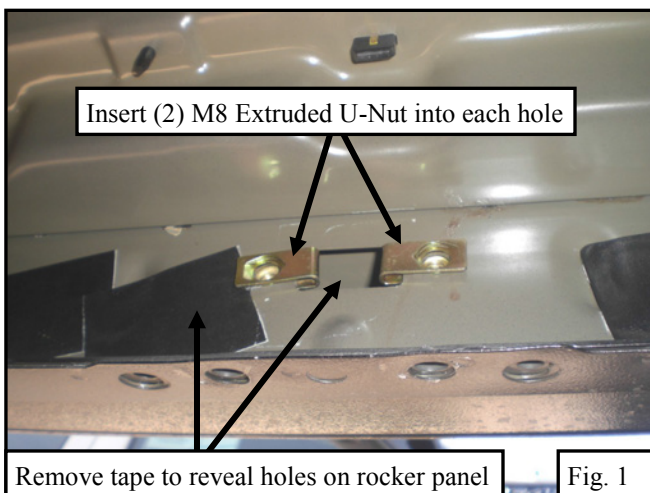

6. Align and adjust the step bar and brackets as necessary then tighten and torque all fasteners as follows: M8 to 20 ft-lbs, M10 30 ft-lbs.
7. Repeat for the passenger side.

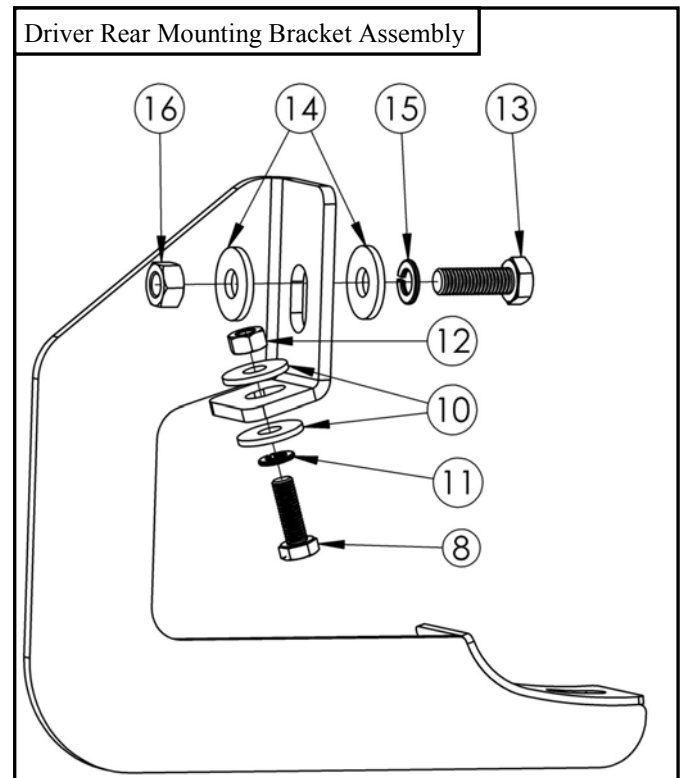
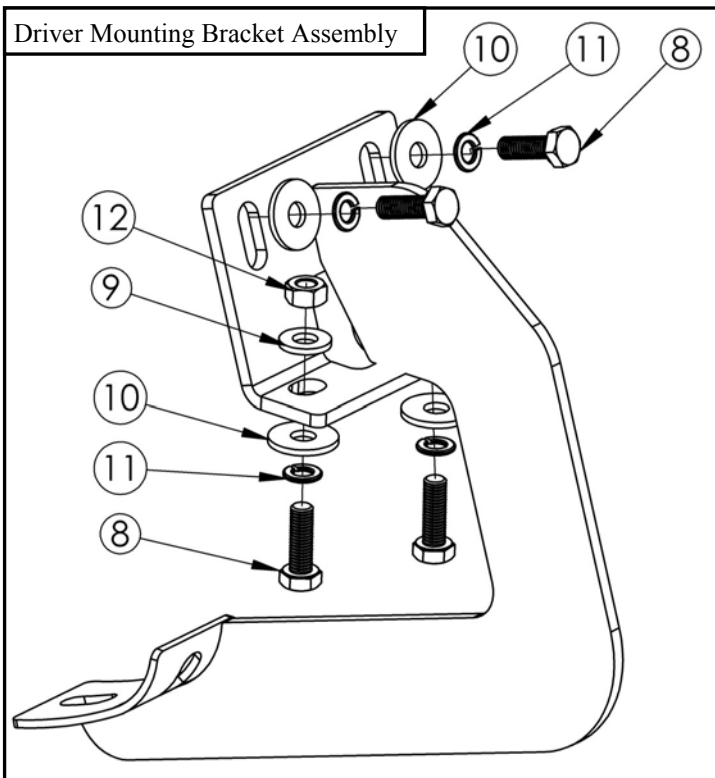
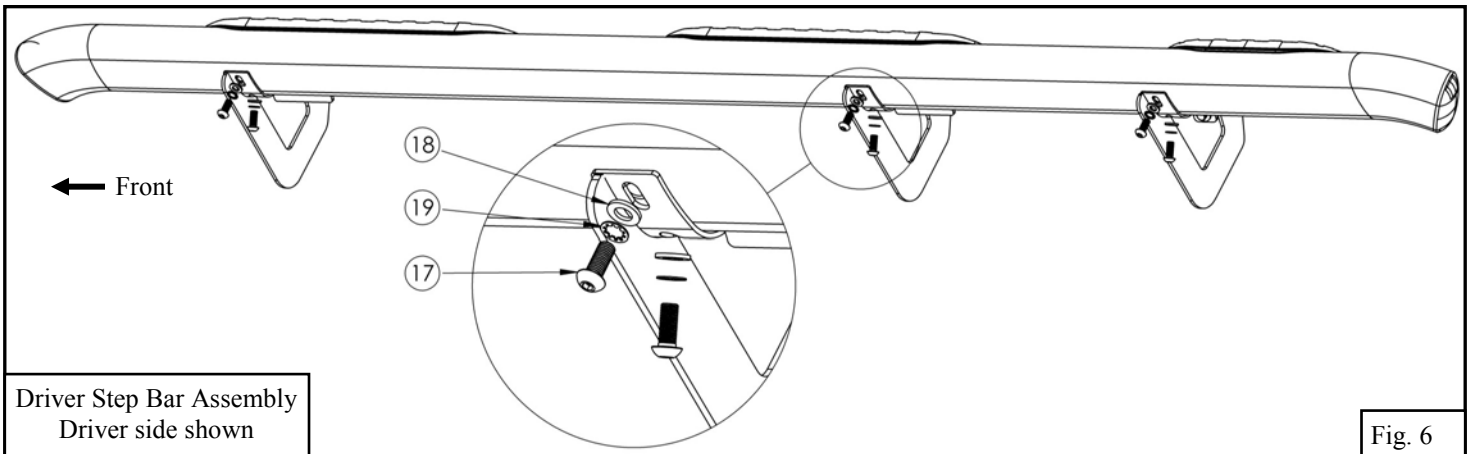
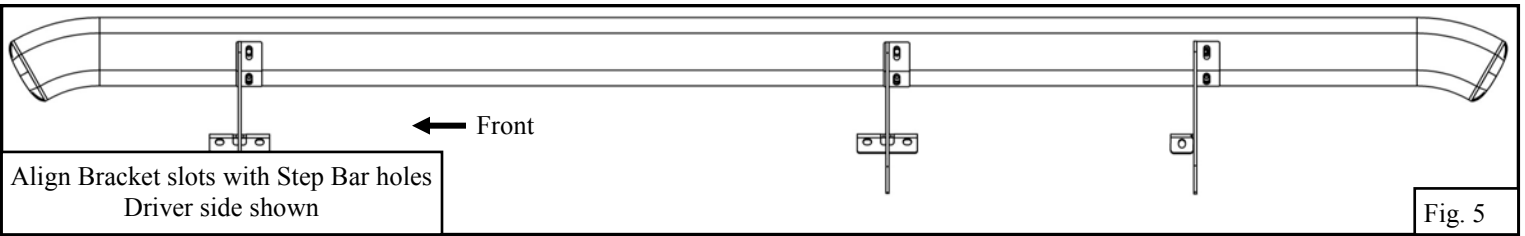



CARE INSTRUCTIONS

- REGULAR WAXING IS RECOMMENDED. DO NOT USE ANY TYPE OF POLISH OR WAX THAT MAY CONTAIN ABRASIVES.
- STAINLESS STEEL PRODUCTS CAN BE CLEANED WITH MILD SOAP AND WATER. STAINLESS STEEL POLISH SHOULD BE USED TO POLISH SMALL SCRATCHES.
- GLOSS BLACK FINISHES SHOULD BE CLEANED WITH MILD SOAP AND WATER.