



SIGNATURE OF QUALITY

INSTALLATION INSTRUCTIONS

APPLICATION: 2005-08 DODGE DAKOTA QUAD CAB

AUTOMOTIVE PRODUCTS, INC.

MOUNT KIT
27-1655
SURE-GRIP
BOARDS
27-6150
27-6155
27-6550

SURE-GRIP
OPTIONAL LIGHT
KIT
27-6000

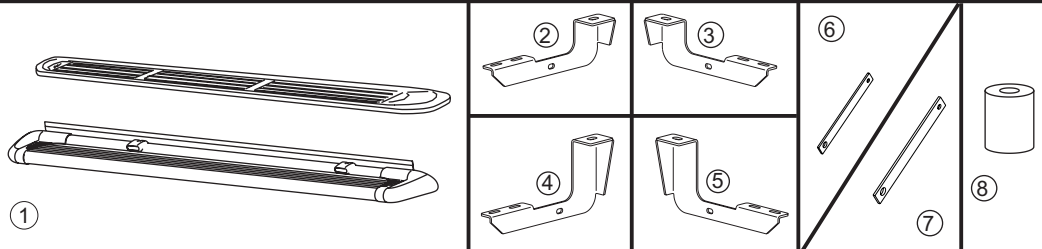

ITEM	QTY	CONTENTS	TOOLS
1	2	STEP BOARD (PURCHASED SEPARATELY)	3/4" SOCKET 9/16" SOCKET 18MM SOCKET 9/16" WRENCH DRILL MOTOR RATCHET SOCKET DRIVER TORQUE WRENCH
2,3	4	FRONT/CENTER BRACKET, PASSENGER (2) AND DRIVER (3)	
4,5	2	REAR BRACKET, PASSENGER (4) AND DRIVER (5)	
6	2	FRONT SUPPORT BRACE	
7	2	REAR SUPPORT BRACE	
8	2	SPACER TUBE (CENTER BRACKET ONLY)	
9	4	M12 X 120MM HEX HEAD BOLT	
10	2	M12 X 130MM HEX HEAD BOLT (CENTER BRACKET ONLY)	
11	4	3/8-16 X 1.25" HEX HEAD BOLT	
12	8	3/8" FLAT WASHER	
13	4	3/8" LOCK WASHER	
14	4	3/8-16 HEX NUT	
15	4	1/4-20 X 1.0" SELF DRILLING BOLT	
16	12	5/16-18 X .75 SQUARE HEAD BOLT	
17	12	5/16" FLAT WASHER	
18	12	5/16" LOCK NUT	
19	6	1/2" FLAT WASHER	
20	6	1/2" LOCK WASHER	

- STEP 1. Remove contents from box and check for damage. Verify all parts are present. Read and understand instructions before beginning. It is strongly recommended to install the Sure Grip Gap Strip for these vehicle applications.
- STEP 2. Attach mounting brackets as shown. **SEE FIGURES 1, 2, 3 AND 4.**
- STEP 3. Insert square head bolts as shown (3 per slot, 6 per board). **SEE FIGURES 5 AND 6. NOTE:** For lighted boards, run wiring harness prior to attaching board to brackets (refer to Step 6). **SEE FIGURES 5, 6 AND 10.** Run longer wire harness on passenger side.
- STEP 4. For Sure-Grip Running Boards, slide closure strip as shown. Set lights (if purchased) in appropriate location. Attach to Sure-Grip Running Board as shown. **SEE FIGURE 8.** Drill hole through plastic strip and run wires as shown. **SEE FIGURE 9.**
- STEP 5. Attach board to brackets as shown. Make sure board and brackets are properly aligned and tighten fasteners. Recommended torque values are 26 FT. LBS. for 3/8" fasteners, 23 FT.LBS. for 8mm fasteners, 10 FT.LBS. for 5/16" square head fasteners and 7 FT. LBS. for 1/4" fasteners. **SEE FIGURE 6.**
- NOTE:** For lighted version of Molded Step Board, remove plastic cover from each end of under side of board. Proceed to Steps 6-7.

WARNING: INSTALLING LIGHT HARNESS REQUIRES SPLICING INTO VEHICLES ELECTRICAL SYSTEM. WESTIN RECOMMENDS USING A PROFESSIONAL FOR THIS INSTALLATION. NOTE: AVOID AREAS OF EXCESSIVE HEAT, VIBRATION, PINCH OR ROTATION WHEN SECURING HARNESS TO VEHICLE. CAUTION: ALWAYS USE A FUSED(+) POSITIVE SUPPLY SOURCE. UNDERCOAT SEAL FOR HARSH WEATHER.

HINT: Molded Step Boards: For longevity, check rubber seals before installation. Rubber grommets around red and blue wires going into rear sockets, should be inserted and recessed about 1/4". **NOTE:** Remove bulbs and apply white grease into sockets and replace bulbs. Apply RTV Silicone where lights go into socket. Install lights and run wire loom as shown. **SEE FIGURE 6.** For Sure-Grip Running Boards, run wire loom down center as shown. **SEE FIGURE 5.**

- STEP 6. Determine whether your vehicle has a positive or negative switching courtesy system or an auxiliary light source (most Fords). Obtain an accurate wiring diagram for your vehicle's courtesy light system.
- For positive and negative switching:**
Locate a pass-through point (usually under carpet at driver side door sill) for the wire harness. Locate main courtesy wire (usually wire lead to dome light). **NOTE:** If you do not use the main courtesy wire, lights will only function when one door is open. Route wire harness so that the 2 female connections (from step board) are nearest to pass thru point. *Connect opposite step board lead to either connection. Connect the splicing lead to remaining female socket and route one wire thru pass thru point. **SEE FIGURE 10.**

VERY IMPORTANT - Double check that your system has positive or negative switching.

For positive switching only: Connect positive wire to main courtesy system, (usually wire lead to dome light). **TEST CONTINUITY BEFORE CONNECTING BY OPENING AND CLOSING ALL DOORS.** Ground remaining wire.

For negative switching only: Connect negative wire to main courtesy system, (usually wire lead to dome light but sometimes from dome light to courtesy ECU). **TEST GROUND CONTINUITY BEFORE CONNECTING BY OPENING AND CLOSING ALL DOORS.** Connect remaining wire to battery using a 5A fuse.

**Be sure that you have not routed any wires near moving parts (i.e.. driveshaft) or near any heat generating source (i.e.. transmission, engine, exhaust).

Auxiliary Light source:

Locate auxiliary light source connection under vehicle (usually attached to back side of front or rear fender well (refer to vehicles owners manual). **SEE FIGURE 10.** **TEST SOURCE BEFORE CONNECTING.** Connect splicing leads to aux light source. test step board lights for proper function by opening and closing doors.

- STEP 7. Under-coat board, brackets and electrical wires, connections and lenses for harsh weather conditions. Reinstall plastic cover on underside of Step boards. **INSTALLATION IS COMPLETE.**

FINISH PROTECTION

Westin products have a high quality finish that must be cared for like any other exposed finish on the vehicle. Protect the finish with a non-abrasive automotive wax, (e.g. Pure Carnauba) on a regular basis. The use of any soap, polish or wax that contains an abrasive is detrimental, as the compounds scratch the finish and open it to corrosion.

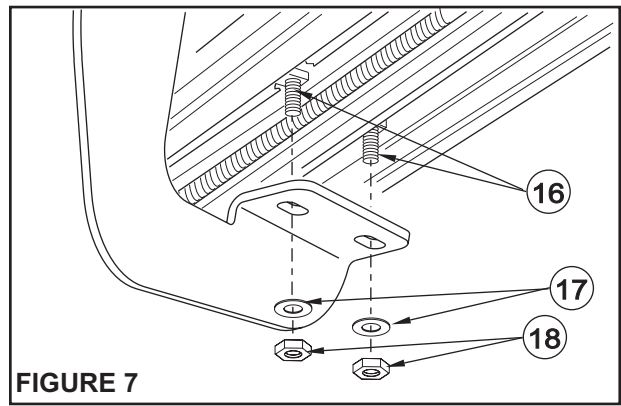
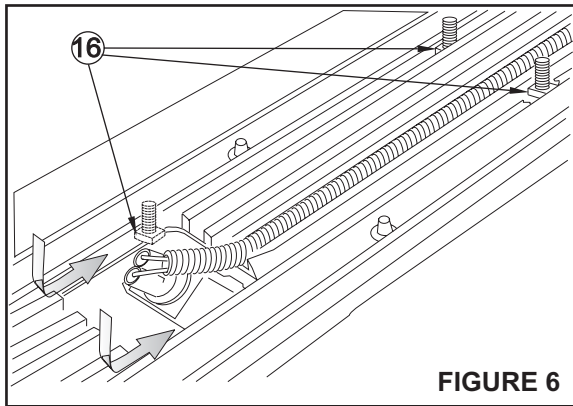
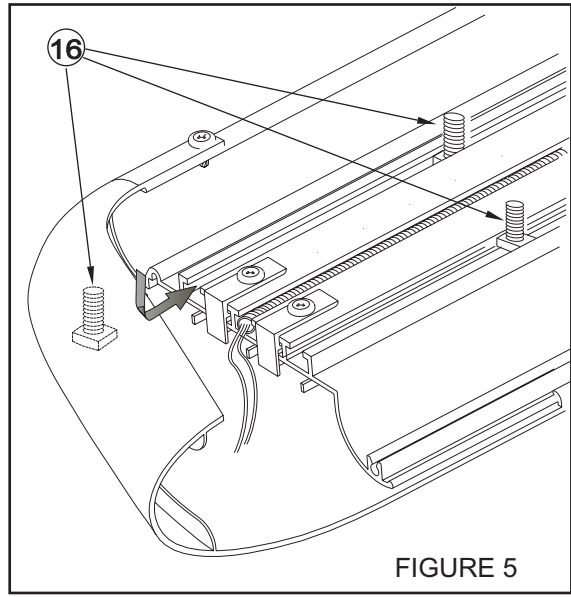
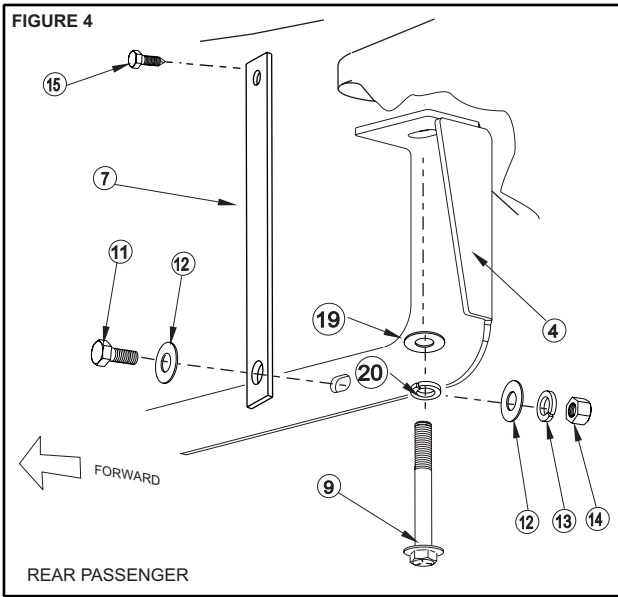
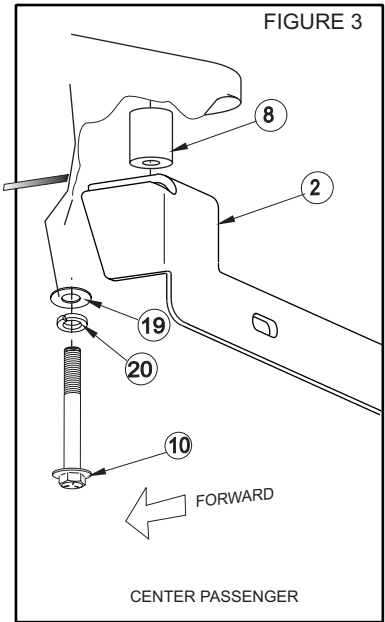
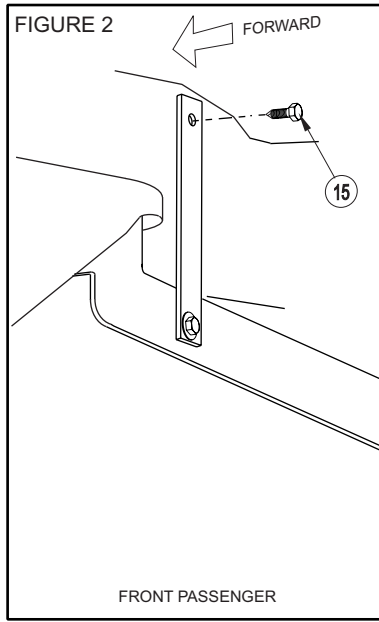
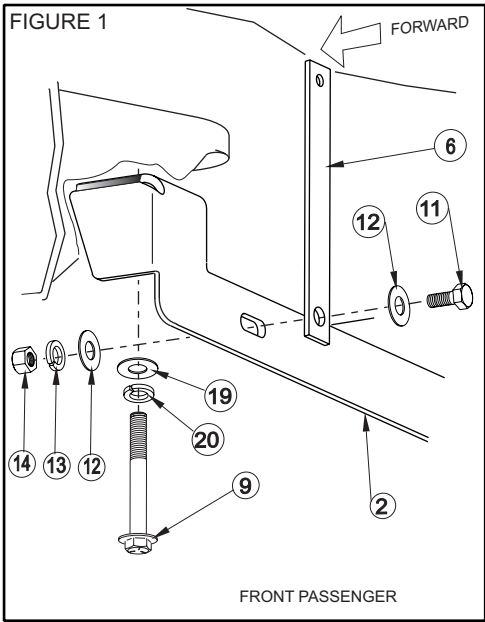

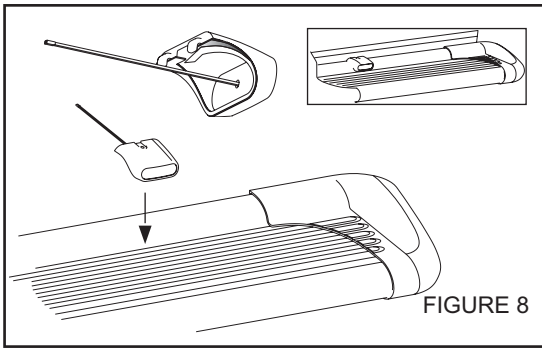

FIGURE 8

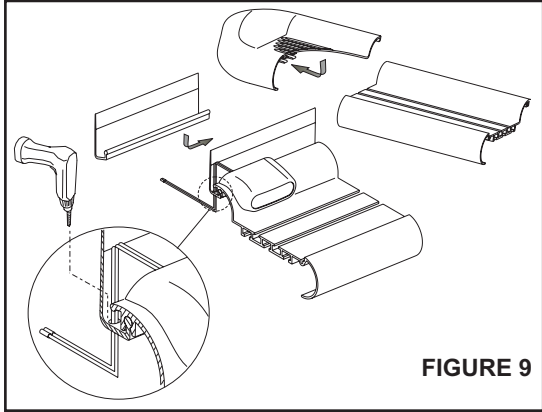

FIGURE 9

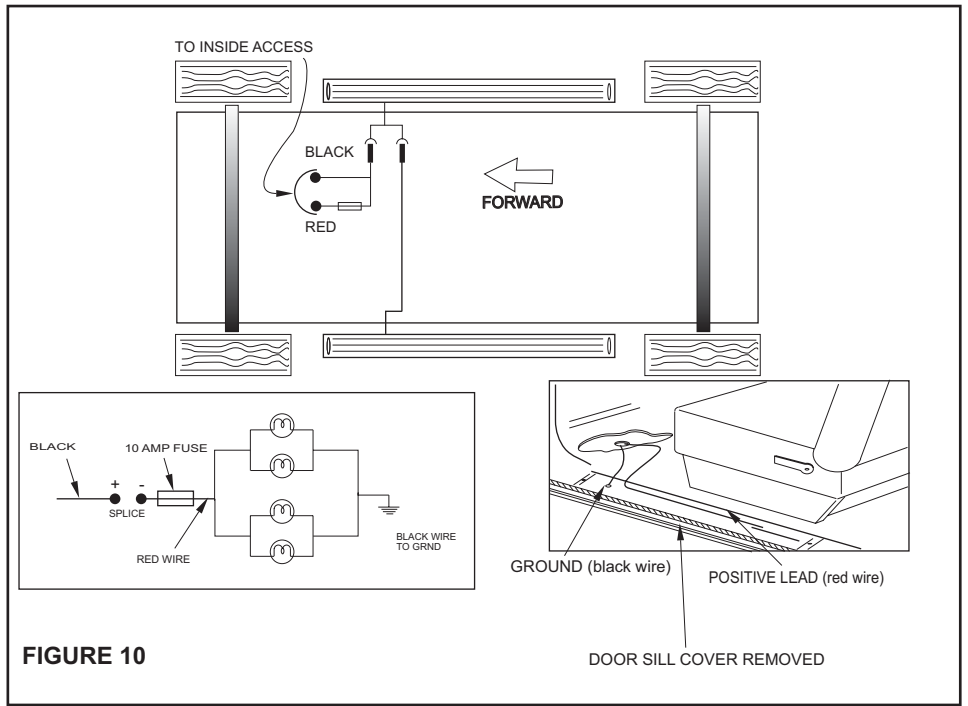

FIGURE 10