



SIGNATURE OF QUALITY

# INSTALLATION INSTRUCTIONS

APPLICATION: 2007-08 BUICK ENCLAVE/GMC ACADIA/SATURN OUTLOOK

AUTOMOTIVE PRODUCTS, INC.

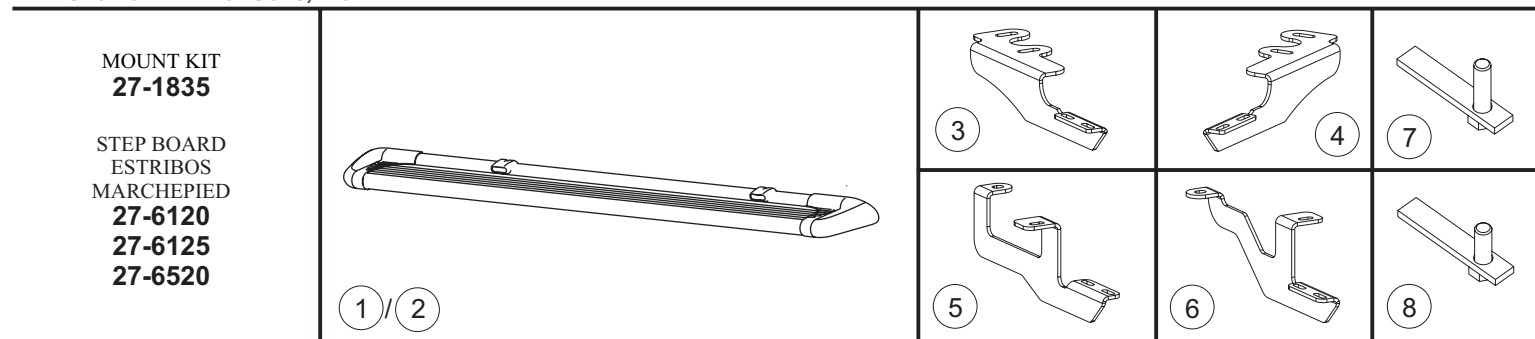

ITEM	QTY	CONTENTS	TOOLS
1,2	2	STEP BOARD, PASSENGER (1) AND DRIVER (2) (SOLD SEPARATELY)	3/4" SOCKET 9/16" SOCKET 1/2" SOCKET RATCHET RATCHET EXTENSION TORQUE WRENCH
3,4	2	FRONT BRACKET, PASSENGER (3) AND DRIVER (4)	
5,6	2	REAR BRACKET, PASSENGER (5) AND DRIVER (6)	
7	4	1/2-13 X 2.00" BOLT PLATE ASSEMBLY	
8	2	1/2-13 X 1.50" BOLT PLATE ASSEMBLY	
9	2	3/8-16 BRIDGE WELD NUT	
10	6	1/2" FLAT WASHER	
11	6	1/2" LOCK WASHER	
12	6	1/2-13 HEX NUT	
13	2	3/8-16 X 1.25" HEX HEAD BOLT	
14	2	3/8" FLAT WASHER	
15	2	3/8" LOCK WASHER	
16	2	3/8-16 HEX NUT	
17	8	5/16-18 X .75" SQUARE HEAD BOLT	
18	8	5/16" FLAT WASHER	
19	8	5/16-18 LOCK NUT	
20	2	PLASTIC WASHER	

- STEP 1. Remove contents from box and check for damage. Verify all parts are present. Read and understand instructions before beginning. **NOTE:** Westin does not recommend using closure strip for this application.
- STEP 2. Determine passenger and driver brackets.
- STEP 3. Attach front driver side bracket using two 1/2-13 x 2.00" bolt plates, 1/2" flat washers, 1/2" lock washers, and 1/2-13 hex nuts as shown. **SEE FIGURE 1.**
- STEP 4. Thread 3/8-16 x 1.25" hex head bolt through bridge weld nut, insert into hole, and use plastic washer to hold in place. **SEE FIGURE 2.**
- STEP 5. Insert 1/2-13 x 1.50" bolt plate into hole. **SEE FIGURE 2.**
- STEP 6. Attach rear driver side bracket to the previously inserted bolt plates. **SEE FIGURE 2.**
- STEP 7. Insert square head bolts as shown (2 per slot, 4 per Step board/Running board). **SEE FIGURE 4.**
- STEP 8. For Aluminum Running boards. Set lights (if purchased) in appropriate location. Attach to running board as shown. Run wires as shown. **SEE FIGURE 5.**
- STEP 9. Attach Step board to brackets as shown. **SEE FIGURE 6.** Make sure step board and brackets are properly aligned and tighten fasteners. Recommended torque values are 64 Ft. Lbs. for 1/2" fasteners, 26 Ft. Lbs. for 3/8" fasteners, and 10 Ft. Lbs. for 5/16" square head fasteners. Repeat installation for passenger side. Make sure that the front passenger bracket does not interfere with the metal fuel line. **SEE FIGURE 3.**

**WARNING: INSTALLING LIGHT HARNESS REQUIRES SPLICING INTO VEHICLES ELECTRICAL SYSTEM. WESTIN RECOMMENDS USING A PROFESSIONAL FOR THIS INSTALLATION. NOTE: AVOID AREAS OF EXCESSIVE HEAT, VIBRATION, PINCH OR ROTATION WHEN SECURING HARNESS TO VEHICLE. CAUTION: ALWAYS USE A FUSED(+) POSITIVE SUPPLY SOURCE. UNDERCOAT SEAL FOR HARSH WEATHER.**

- For Aluminum Running board, run wire loom down center as shown. **SEE FIGURES 4 AND 5.**
- STEP 10. Determine whether your vehicle has a positive or negative switching courtesy system or an auxiliary light source (most Fords). Obtain an accurate wiring diagram for your vehicle's courtesy light system.
  - For Positive and negative switching:** Locate a pass-through point (usually under carpet at driver side door sill) for the wire harness. Locate main courtesy wire (usually wire lead to dome light). **NOTE:** If you do not use the main courtesy wire, lights will only function when one door is open. Route wire harness so that the 2 female connections (from step board) are nearest to pass thru point.\*Connect opposite Step board lead to either connection. Connect the splicing lead to remaining female socket and route one wire thru pass thru point. **SEE FIGURE 7.**

**VERY IMPORTANT** - Double check that your system has positive or negative switching.

**For positive switching only:** Connect positive wire to main courtesy system, (usually wire lead to dome light). TEST CONTINUITY BEFORE CONNECTING BY OPENING AND CLOSING ALL DOORS. Ground remaining wire.

**For negative switching only:** Connect negative wire to main courtesy system, (usually wire lead to dome light but sometimes from dome light to courtesy ECU). TEST GROUND CONTINUITY BEFORE CONNECTING BY OPENING AND CLOSING ALL DOORS. Connect remaining wire to

battery using a 5A fuse.

\*\*Be sure that you have not routed any wires near moving parts (i.e.. driveshaft) or near any heat generating source (i.e.. transmission, engine, exhaust).

**Auxiliary Light source:**

Locate auxiliary light connection under vehicle (usually attached to back side of front or rear fender well (refer to vehicles owners manual) (**SEE FIGURE 7**). TEST SOURCE BEFORE CONNECTING. Connect splicing leads to aux light source. test step board lights for proper function by opening and closing doors.

**FINISH PROTECTION**

Westin products have a high quality finish that must be cared for like any other exposed finish on the vehicle. Protect the finish with a non-abrasive automotive wax, (e.g. Pure Carnauba) on a regular basis. The use of any soap, polish or wax that contains an abrasive is detrimental, as the compounds scratch the finish and open it to corrosion.

