



SIGNATURE OF QUALITY

AUTOMOTIVE PRODUCTS, INC.

# INSTALLATION INSTRUCTIONS

APPLICATION: 2007-08 FORD EDGE/LINCOLN MKX

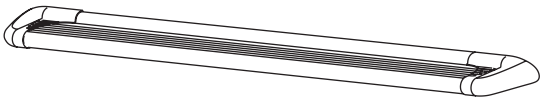
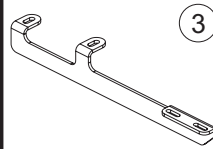
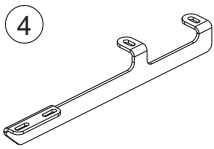
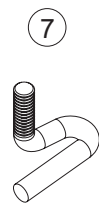
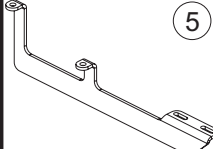
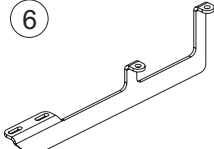
<p>MOUNT KIT</p> <p><b>27-1825</b></p> <p>STEP BOARD ESTRIBOS MARCHEPIED</p> <p><b>27-6120</b> <b>27-6125</b> <b>27-6520</b></p>	 <p>(1) / (2)</p>	 <p>(3)</p>	 <p>(4)</p>	 <p>(7)</p>
 <p>(5)</p>	 <p>(6)</p>			

ITEM	QTY	CONTENTS	TOOLS
1,2	2	STEP BOARD, PASSENGER (1) AND DRIVER (2) (SOLD SEPARATELY)	1/2" SOCKET 9/16" SOCKET 13MM SOCKET RATCHET RATCHET EXTENSION TORQUE WRENCH
3,4	2	FRONT BRACKET, PASSENGER (3) AND DRIVER (4)	
5,6	2	REAR BRACKET, PASSENGER (5) AND DRIVER (6)	
7	2	"J" BOLT	
8	4	PLASTIC WASHER	
9	2	3/8-16 BRIDGE WELD NUT	
10	2	3/8-16 X 1.25" HEX HEAD BOLT	
11	4	3/8" FLAT WASHER	
12	4	3/8" LOCK WASHER	
13	4	3/8-16 HEX NUT	
14	8	5/16-18 X .75" SQUARE HEAD BOLT	
15	8	5/16" FLAT WASHER	
16	8	5/16-18 LOCK NUT	

- STEP 1.** Remove the contents from box and check for damage. Verify all parts are present. Read instructions completely before beginning. **NOTE:** Westin does not recommend using closure strip for this application or light kit 27-6000.
- STEP 2.** Determine passenger and driver brackets.
- STEP 3.** Thread 3/8-16 x 1.25" hex head bolt through bridge weld nut, insert into outer hole, and use a plastic washer to hold in place. Insert J-bolt into inner hole and use a plastic washer to hold in place. **SEE FIGURE 1.**
- STEP 4.** Attach front passenger side bracket to the previously assembled 3/8" bolt plate and "J" bolt using two 3/8" flat washers, 3/8" lock washers, and 3/8-16 hex nuts as shown. **SEE FIGURE 1.**
- STEP 5.** Remove the two foremost factory bolts from the rear suspension bracket. Slide bracket into place and secure using factory bolts. **SEE FIGURE 2**
- STEP 6.** Insert square head bolts as shown (2 per slot, 4 per board). **SEE FIGURE 4.**
- STEP 7.** Attach step board to brackets as shown. **SEE FIGURE 3.** Make sure step board and brackets are properly aligned and tighten fasteners. Recommended torque values are 31 Ft. Lbs. for factory bolts, 26 Ft. Lbs. for 3/8" fasteners, and 10 Ft. Lbs. for 5/16" square head fasteners. **NOTE:** Brackets will not extend out perpendicular to vehicle. They will extend out at an angle.
- STEP 8.** Repeat installation for drivers side.

### FINISH PROTECTION

Westin products have a high quality finish that must be cared for like any other exposed finish on the vehicle. Protect the finish with a non-abrasive automotive wax, (e.g. Pure Carnauba) on a regular basis. The use of any soap, polish or wax that contains an abrasive is detrimental, as the compounds scratch the finish and open it to corrosion.

