

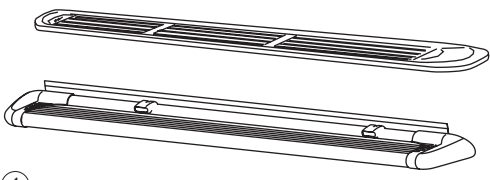
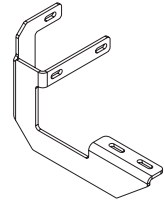

AUTOMOTIVE PRODUCTS, INC.

INSTALLATION INSTRUCTIONS

APPLICATION: 2005-08 JEEP GRAND CHEROKEE
2006-08 JEEP COMMANDER

| MOUNT KIT 27-1785 | | SURE-GRIP OPTIONAL LIGHT KIT 27-6000 |  |  |
|------------------------------------------------|------------------------------------------------------|------------------------------------------------------------|------------------------------------------------------------------------------------|-------------------------------------------------------------------------------------|
| MOLDED STEP BOARDS 27-0000 27-0005 | SURE-GRIP BOARDS 27-6120 27-6125 27-6520 | | | |
| ITEM | QTY | CONTENTS | TOOLS | |
| 1,2 | 2 | STEP BOARD, PASSENGER (1) AND DRIVER (2) (SOLD SEPARATELY) | TWO 13MM WRENCH 1/2" SOCKET RATCHET TORQUE WRENCH | |
| 3 | 4 | MOUNT BRACKET | | |
| 4 | 8 | 5/16-18 X .75" SQUARE HEAD BOLT | | |
| 5 | 8 | 5/16" FLAT WASHER | | |
| 6 | 8 | 5/16-18 LOCK NUT | | |
| 7 | 12 | M8-1.25 X 30MM HEX HEAD BOLT | | |
| 8 | 20 | 8MM FLAT WASHER | | |
| 9 | 12 | 8MM LOCK WASHER | | |
| 10 | 8 | M8-1.25 HEX NUT | | |
| 11 | 4 | M8-1.25 EXTRUDED U-NUT | | |

STEP 1. Remove contents from box and check for damage. Verify all parts are present. Read instructions completely before beginning. It is strongly recommended to install the Sure Grip Gap Strip for these vehicle applications.

STEP 2. Both front and rear brackets are the same for each side.

STEP 3. Locate driver side mounting locations on vehicle. **SEE FIGURE 1.**

STEP 4. Attach brackets to underside of rocker panel as shown. Hand tighten. **SEE FIGURES 1 AND 2.**

For Jeep Commanders only: To attach the passenger side front bracket, remove the four bolts that secure the rear air and heat line shroud. Remove the shroud to gain access to top mounting location on the bracket. After bracket is installed and fasteners are tightened, reattach shroud with the four existing bolts previously removed. **SEE FIGURE 9.**

STEP 5. Insert square head bolts as shown (2 per slot, 4 per Step board/Running board). **SEE FIGURES 4 AND 5. NOTE:** For lighted boards, run wiring harness prior to attaching board to brackets (refer to Step 5). **SEE FIGURES 4, 5 AND 8.** Run longer wire harness on passenger side.

STEP 6. For Sure-Grip Running Boards, slide closure strip as shown. Set lights (if purchased) in appropriate location. Attach to Sure-Grip Running Board as shown. **SEE FIGURE 3.** Drill hole through plastic strip and run wires as shown. **SEE FIGURE 6.**

STEP 7. Attach board to brackets as shown. Make sure board and brackets are properly aligned and tighten fasteners. Recommended torque values are 10 FT.LBS. for 5/16" square head fasteners, 23 FT. LBS for 8MM fasteners and 19 FT.LBS. For factory 8MM fasteners. **SEE FIGURE 7. NOTE:** For lighted version of Molded Step Board, remove plastic cover from each end of under side of board. Proceed to Steps 4-5.

WARNING: INSTALLING LIGHT HARNESS REQUIRES SPLICING INTO VEHICLES ELECTRICAL SYSTEM. WESTIN RECOMMENDS USING A PROFESSIONAL FOR THIS INSTALLATION. NOTE: AVOID AREAS OF EXCESSIVE HEAT, VIBRATION, PINCH OR ROTATION WHEN SECURING HARNESS TO VEHICLE. CAUTION: ALWAYS USE A FUSED(+) POSITIVE SUPPLY SOURCE. UNDERCOAT SEAL FOR HARSH WEATHER.

HINT: Molded Step Boards: For longevity, check rubber seals before installation. Rubber grommets around red and blue wires going into rear sockets, should be inserted and recessed about 1/4". **NOTE:** Remove bulbs and apply white grease into sockets and replace bulbs. Apply RTV Silicone where lights go into socket. Install lights and run wire loom as shown. **SEE FIGURE 5.** For Sure-Grip Running Boards, run wire loom down center as shown. **SEE FIGURE 4.**

STEP 8. Determine whether your vehicle has a positive or negative switching courtesy system or an auxiliary light source (most Fords). Obtain an accurate wiring diagram for your vehicle's courtesy light system.

For positive and negative switching:

Locate a pass-through point (usually under carpet at driver side door sill) for the wire harness. Locate main courtesy wire (usually wire lead to dome light). **NOTE:** If you do not use the main courtesy wire, lights will only function when one door is open. Route wire harness so that the 2 female connections (from step board) are nearest to pass thru point.*Connect opposite step board lead to either connection. Connect the splicing lead to remaining female socket and route one wire thru pass thru point. **SEE FIGURE 8.**

VERY IMPORTANT - Double check that your system has positive or negative switching.

For positive switching only: Connect positive wire to main courtesy system, (usually wire lead to dome light). **TEST CONTINUITY BEFORE CONNECTING BY OPENING AND CLOSING ALL DOORS.** Ground remaining wire.

For negative switching only: Connect negative wire to main courtesy system, (usually wire lead to dome light but sometimes from dome light to courtesy ECU). **TEST GROUND CONTINUITY BEFORE CONNECTING BY OPENING AND CLOSING ALL DOORS.** Connect remaining wire to battery using a 5A fuse.

**Be sure that you have not routed any wires near moving parts (i.e.. driveshaft) or near any heat generating source (i.e.. transmission, engine, exhaust).

Auxiliary Light source:

Locate auxiliary light source connection under vehicle (usually attached to back side of front or rear fender well (refer to vehicles owners manual). **SEE FIGURE 8. TEST SOURCE BEFORE CONNECTING.** Connect splicing leads to aux light source. test step board lights for proper function by opening and closing doors.

STEP 9. Under-coat board, brackets and electrical wires, connections and lenses for harsh weather conditions. Reinstall plastic cover on underside of Step boards. **INSTALLATION IS COMPLETE.**

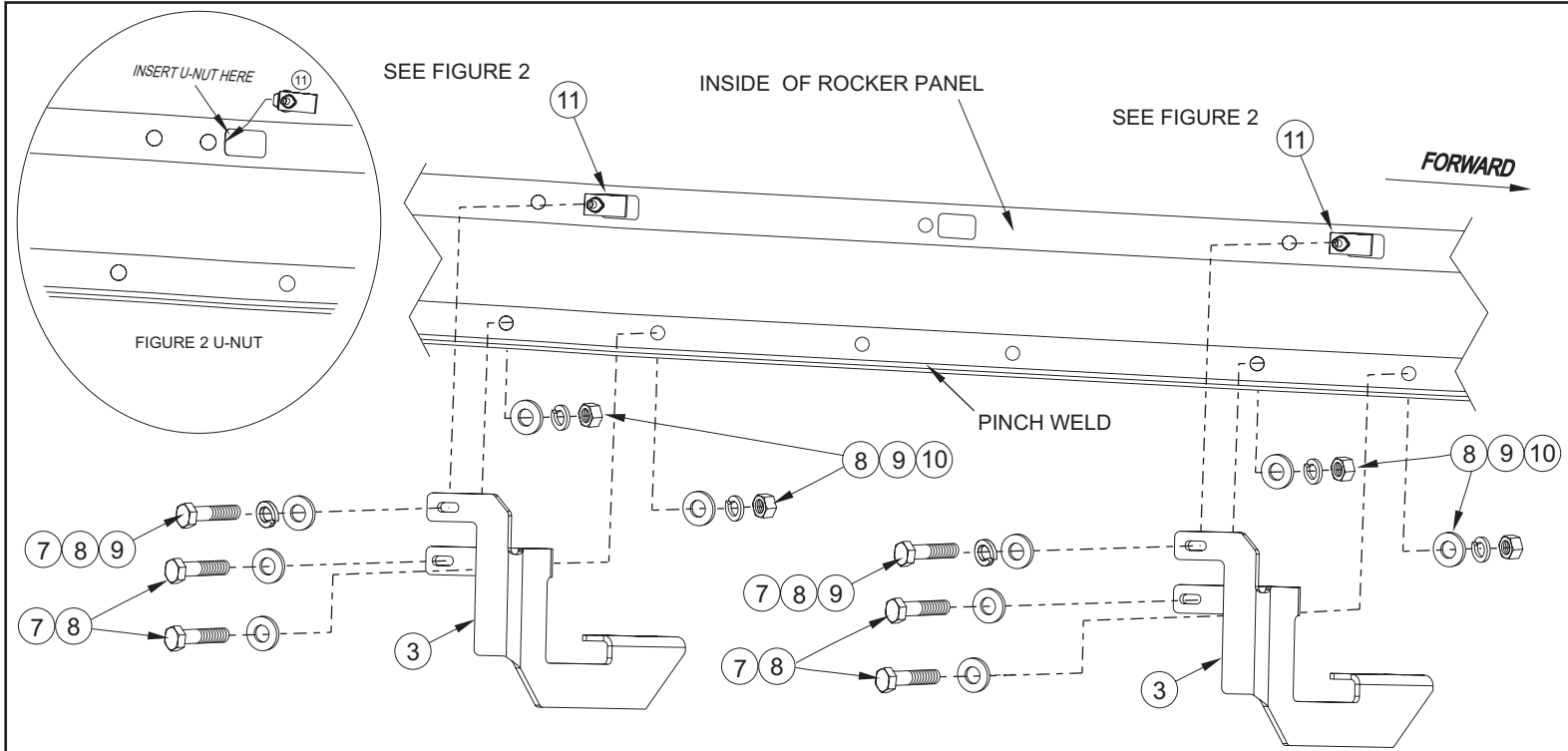

FIGURE 1 INSTALLATION VIEW OF DRIVER SIDE SHOWN, PASSENGER SIDE OPPOSITE

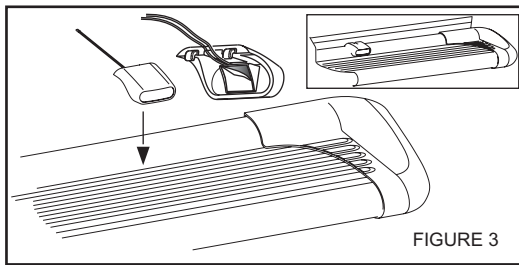

FIGURE 3

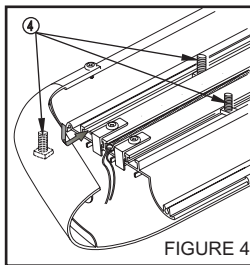

FIGURE 4

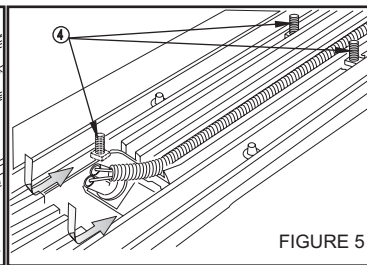

FIGURE 5

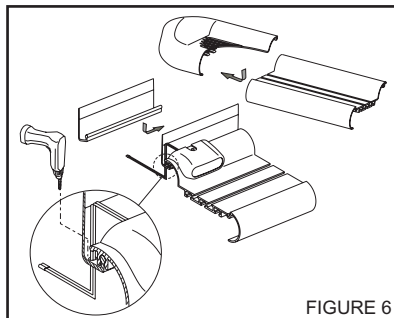

FIGURE 6

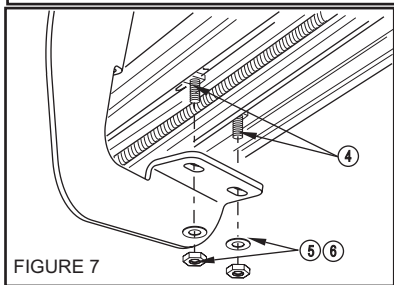

FIGURE 7

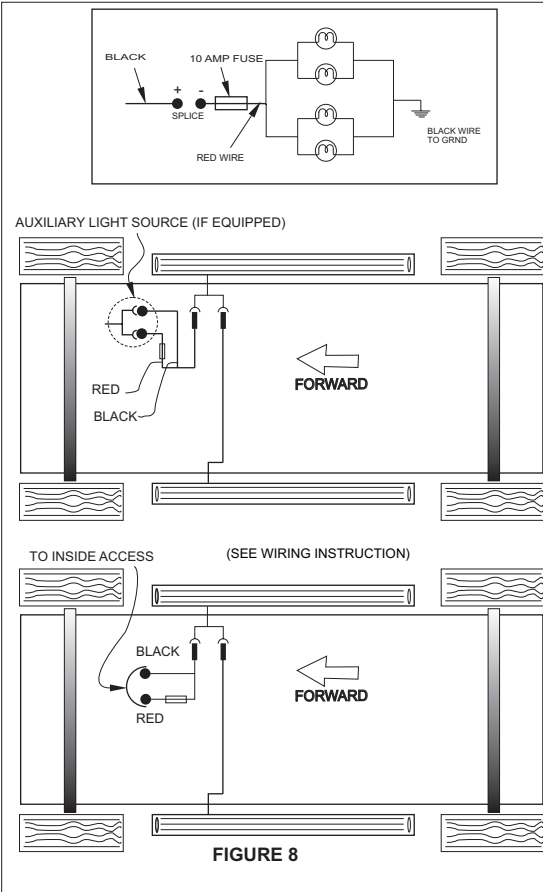

FIGURE 8

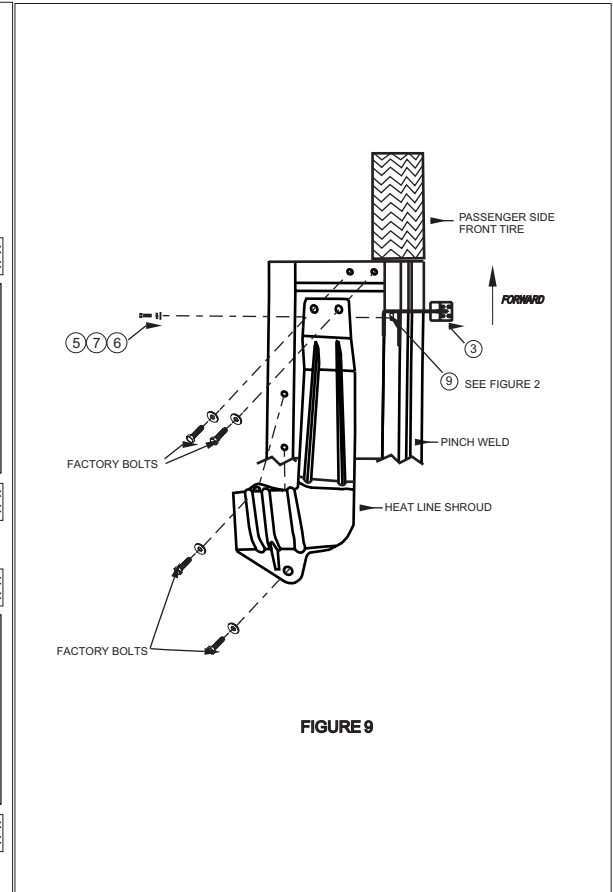

FIGURE 9