



SIGNATURE OF QUALITY

AUTOMOTIVE PRODUCTS, INC.

INSTALLATION INSTRUCTIONS

APPLICATION: '03 & UP HONDA PILOT
'02-04 ACURA MDX

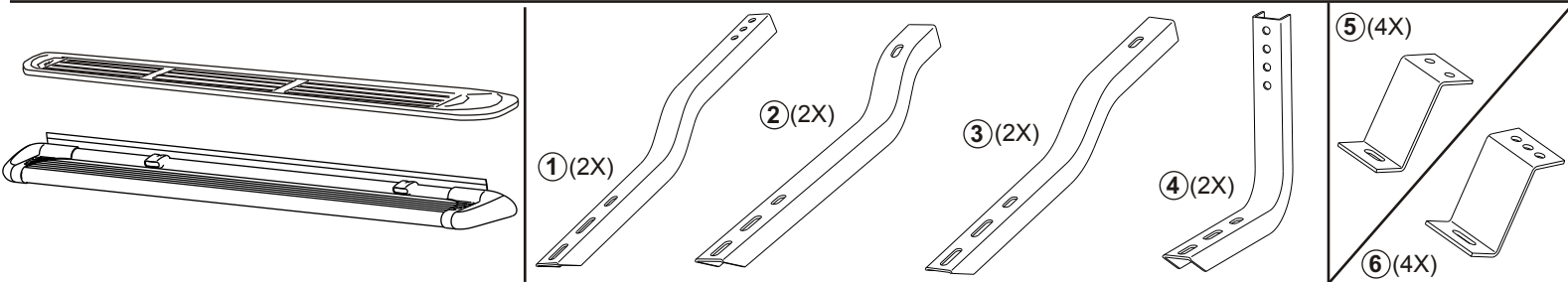

	ITEM	QTY	CONTENTS	TOOLS
Mount Kit #27-1445	1	2	MAIN FRONT BRACKET	7/16" SOCKET 13mm SOCKET DRILL SOCKET ADAPTER
Lighted Step Board Kit #27-0015	2	2	MAIN MIDDLE / REAR BRACKET	
	3	2	MAIN MIDDLE / FRONT BRACKET	
Unlighted Step Board Kit #27-0010	4	2	MAIN REAR BRACKET	
	5	4	MIDDLE PINCH WELD HANGER	
Brushed Aluminum Running Board Kit #27-6130	6	4	FRONT / REAR PINCH WELD HANGER	
	7	12	M8 X 20mm HEX HEAD BOLT	
Black Aluminum Running Board Kit #27-6135	8	8	5/16" HEX HEAD BOLT	
	9	16	5/16" SQUARE HEAD BOLT	
Aluminum Running Board Light Kit #27-6000	10	44	5/16" FLAT WASHER	
	11	24	5/16" LOCK NUT	
	12	18	1/4" SELF DRILLING SCREW	

- STEP 1.** Remove contents from box and check for damage. Verify all parts are present. Read and understand instructions before beginning.
- STEP 2.** Remove plugs and install middle hanger brackets in locations as shown (See Figure 1, 2, 3 and 4).
- STEP 3.** Attach middle front and middle rear brackets as shown (See Figure 3 and 4).
- STEP 4.** Insert square head bolts as shown (4 per slot, 8 per Step board/Running board) (See Figure 8 and 9). Attach step board to middle brackets. Align and hand tighten (See Figure 11). Locate position for front and rear hangers. Attach to rocker panel as shown (See Figure 5 and 6). Attach front and rear brackets as shown (See Figure 5 and 6). NOTE: For lighted Step board/Running board, run wiring harness prior to attaching step board to brackets (Refer to Step 7) (See Figure 8, 9 & 12). Run longer wire harness on passenger side.
- STEP 5.** For Aluminum Running boards, if desired, slide closure strip as shown. Set lights (if included) in appropriate location. Attach to running board as shown (See Figure 7). Drill hole through plastic strip and run wires as shown (See Figure 10).
- STEP 6.** Attach Step board / Running board to brackets as shown. Align and tighten (See Figure 11). NOTE: For lighted version of Step board, remove plastic cover from each end of under side of Step board. Proceed to Steps 7-8.
- WARNING: INSTALLING LIGHT HARNESS REQUIRES SPLICING INTO VEHICLES ELECTRICAL SYSTEM. WESTIN RECOMMENDS USING A PROFESSIONAL FOR THIS INSTALLATION. NOTE: AVOID AREAS OF EXCESSIVE HEAT, VIBRATION, PINCH OR ROTATION WHEN SECURING HARNESS TO VEHICLE.**
- CAUTION: ALWAYS USE A FUSED(+) POSITIVE SUPPLY SOURCE. UNDERCOAT SEAL FOR HARSH WEATHER.**
- HINT:** Step boards: For Longevity, check rubber seals before installation. Rubber grommets around red and blue wires going into rear sockets, should be inserted and recessed about 1/4". NOTE: Remove bulbs and apply white grease into sockets and replace bulbs. Apply RTV Silicone where lights go into socket. Install lights and run wire loom as shown (See Figure 9). For Aluminum Running board, run wire loom down center as shown (See Figure 8).
- STEP 7.** Determine whether your vehicle has a positive or negative switching courtesy system or an auxiliary light source (most Fords). Obtain an accurate wiring diagram for your vehicle's courtesy light system.
- For Positive and negative switching:**
Locate a pass-through point (usually under carpet at driver side door sill) for the wire harness (see figure 12). Locate main courtesy wire (usually wire lead to dome light). NOTE: If you do not use the main courtesy wire, lights will only function when one door is open. Route wire harness so that the 2 female connections (from step board) are nearest to pass thru point.*Connect opposite Step board lead to either connection. Connect the splicing lead to remaining female socket and route one wire thru pass thru point.
- VERY IMPORTANT - Double check that your system has positive or negative switching.**
- For positive switching only:**
connect positive wire to main courtesy system, (usually wire lead to dome light). TEST CONTINUITY BEFORE CONNECTING BY OPENING AND CLOSING ALL DOORS. Ground remaining wire.
- For negative switching only:**
Connect negative wire to main courtesy system, (usually wire lead to dome light but sometimes from dome light to courtesy ECU). TEST GROUND CONTINUITY BEFORE CONNECTING BY OPENING AND CLOSING ALL DOORS. Connect remaining wire to battery using a 5A fuse.
- Auxiliary Light source:**
Locate auxiliary light source connection under vehicle (usually attached to back side of front or rear fender well (refer to vehicles owners manual) (see figure 12). TEST SOURCE BEFORE CONNECTING. Connect splicing leads to aux light source. test step board lights for proper function by opening and closing doors.
- **Be sure that you have not routed any wires near moving parts (i.e., driveshaft) or near any heat generating source (i.e., transmission, engine, exhaust).
- STEP 8.** Under-coat Step board/Running board, brackets and electrical wires, connections and lenses for harsh weather conditions. Reinstall plastic cover on underside of Step boards. INSTALLATION IS COMPLETE.

FINISH PROTECTION

Westin products have a high quality finish that must be cared for like any other exposed finish on the vehicle. Protect the finish with a non-abrasive automotive wax, (e.g. Pure Carnauba) on a regular basis. The use of any soap, polish or wax that contains an abrasive is detrimental, as the compounds scratch the finish and open it to corrosion.

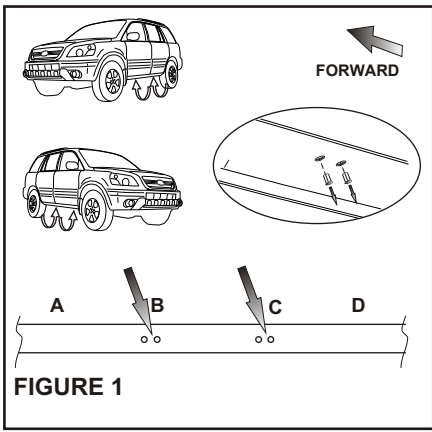

FIGURE 1

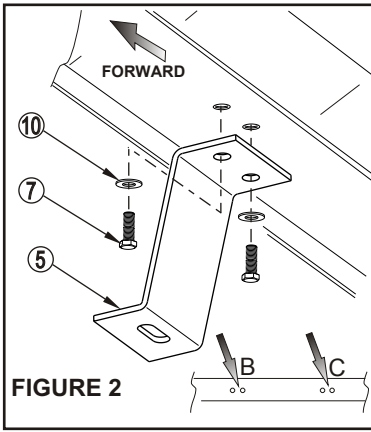

FIGURE 2

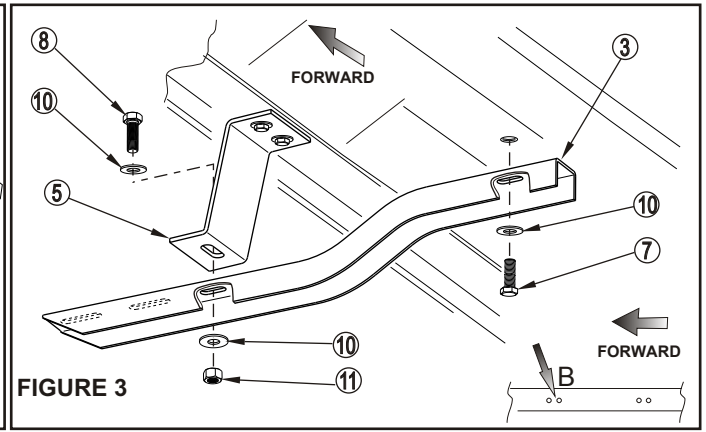

FIGURE 3

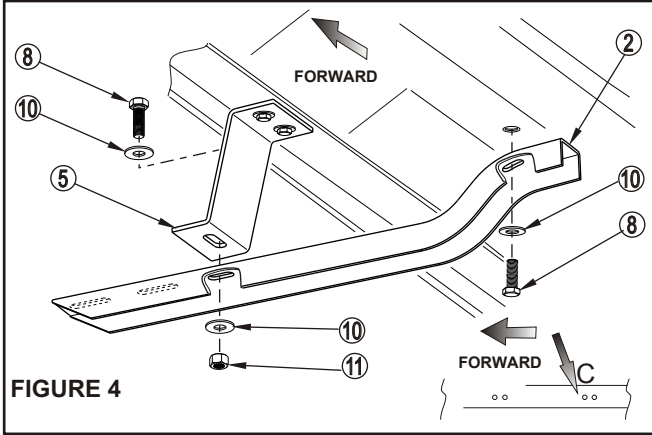

FIGURE 4

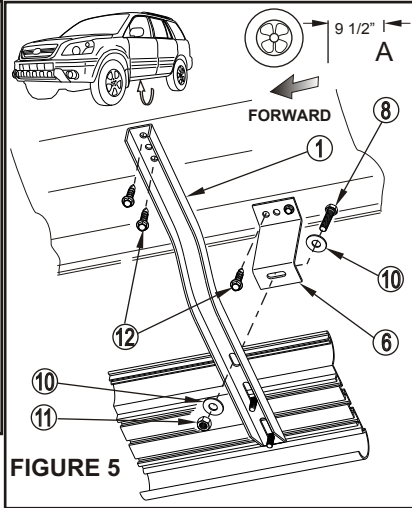

FIGURE 5

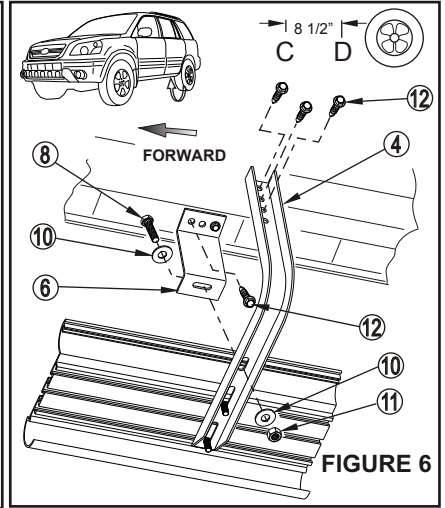

FIGURE 6

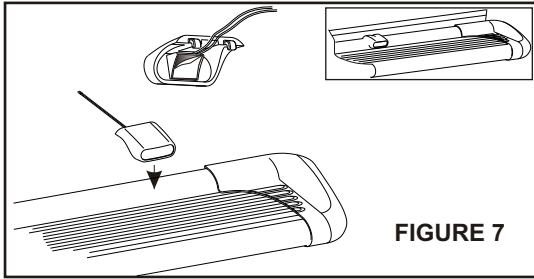

FIGURE 7

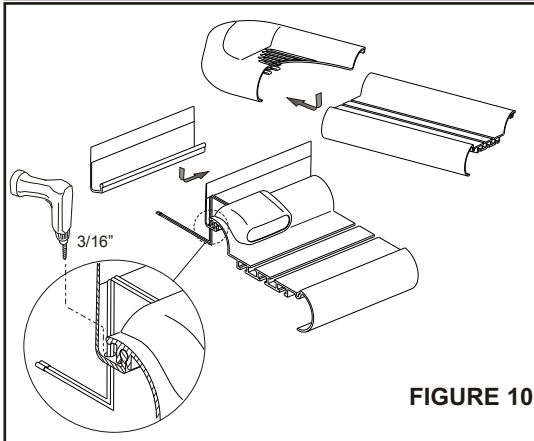

FIGURE 10

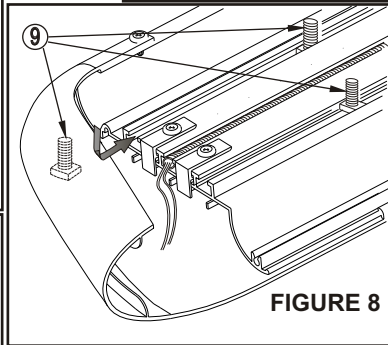

FIGURE 8

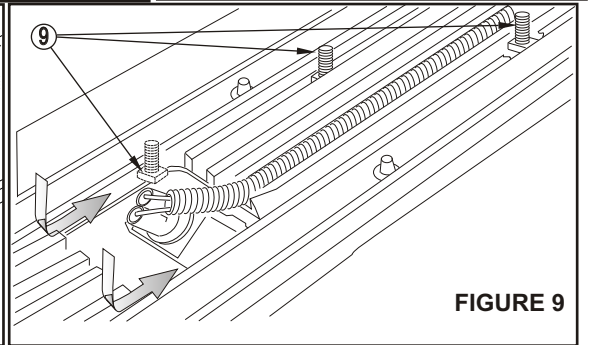

FIGURE 9

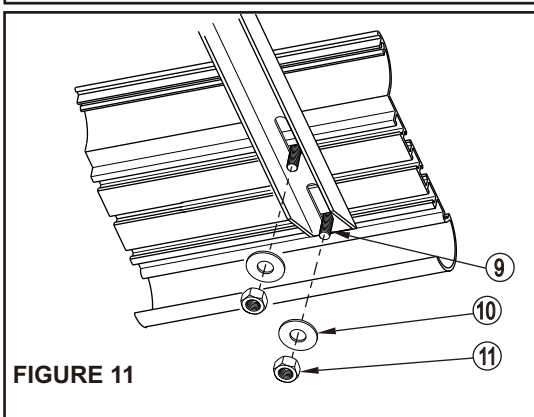
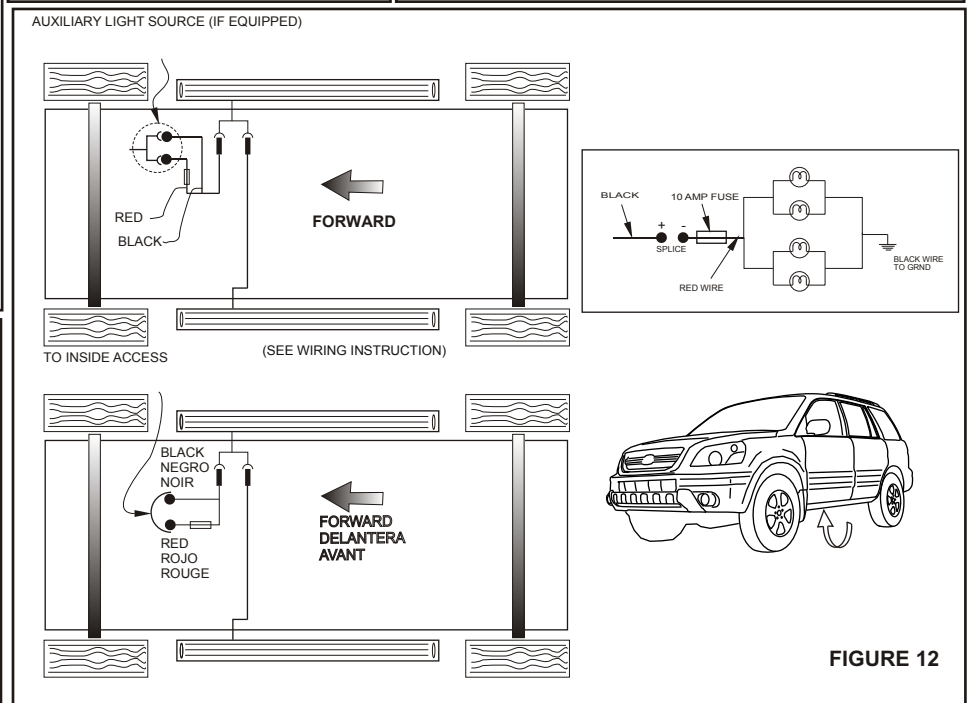

FIGURE 11

FIGURE 12