



SIGNATURE OF QUALITY

INSTALLATION INSTRUCTIONS

APPLICATION: 2002-04 CHEVY ASTRO/GMC SAFARI VAN

AUTOMOTIVE PRODUCTS, INC.

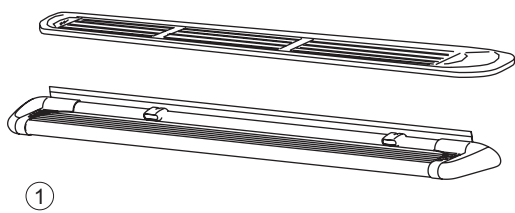
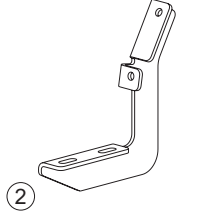
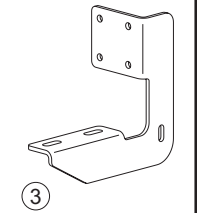
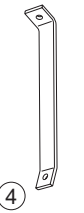
<p>MOUNT KIT 27-1395</p> <p>MOLDED STEP BOARDS 27-0010 27-0015</p>	<p>SURE-GRIP OPTIONAL LIGHT KIT 27-6000</p> <p>SURE-GRIP BOARDS 27-6130 27-6135 27-6530</p>	 <p>①</p>	 <p>②</p>	 <p>③</p>	 <p>④</p>
--	---	---	--	--	--

ITEM	QTY	CONTENTS	TOOLS
1	2	STEP BOARD (PURCHASED SEPARATELY)	1/2" SOCKET 7/16" SOCKET RATCHET DRILL TORQUE WRENCH 5/16" DRILL BIT 3/16" DRILL BIT
2	6	MOUNT BRACKET	
3	2	REAR MOUNT BRACKET (DRIVER SIDE ONLY)	
4	1	SUPPORT BRACE	
5	16	5/16-18 X .75" SQUARE HEAD BOLT	
6	16	5/16" FLAT WASHER	
7	16	5/16-18 LOCK NUT	
8	8	1/4-20 X .75" SELF TAPPING SCREW	
9	12	1/4-20 X 1.00" HEX HEAD BOLT	
10	24	1/4" FLAT WASHER	
11	12	1/4" LOCK WASHER	
12	12	1/4-20 HEX NUT	

- STEP 1. Remove contents from box and check for damage. Verify all parts are present. Read instructions completely before beginning. It is strongly recommended to install the Sure Grip Gap Strip for these vehicle applications.
- STEP 2. Measure and mark pinch weld locations as shown. **SEE FIGURES 1 AND 2.**
- STEP 3. Attach brackets. Mark holes. Remove brackets. Drill holes as shown. **SEE FIGURE 3.**
NOTE: Be sure to use the correct drill bit size for each hole. **SEE FIGURE 3.**
- STEP 4. Attach mounting brackets as shown. **SEE FIGURES 4, 5 AND 6.**
- STEP 5. Insert square head bolts in step boards as shown (4 in each slot, 8 per board). **SEE FIGURES 8 AND 9.**
NOTE: For lighted boards, run wiring harness prior to attaching board to brackets (refer to Step 8). **SEE FIGURES 8, 9 AND 12.** Run longer wire harness on passenger side.
- STEP 6. For Sure-Grip Running Boards, slide closure strip as shown. Set lights (if purchased) in appropriate location. Attach to Sure-Grip Running Board as shown. **SEE FIGURE 7.** Drill hole through plastic strip and run wires as shown. **SEE FIGURE 10.**
- STEP 7. Attach board to brackets as shown. Make sure board and brackets are properly aligned and tighten fasteners. Recommended torque values are 10 FT.LBS. for 5/16" square head fasteners and 7 FT.LBS. for 1/4" fasteners. **SEE FIGURE 11.**

NOTE: For lighted version of Molded Step Board, remove plastic cover from each end of under side of board. Proceed to Steps 8-9.
WARNING: INSTALLING LIGHT HARNESS REQUIRES SPLICING INTO VEHICLES ELECTRICAL SYSTEM. WESTIN RECOMMENDS USING A PROFESSIONAL FOR THIS INSTALLATION. NOTE: AVOID AREAS OF EXCESSIVE HEAT, VIBRATION, PINCH OR ROTATION WHEN SECURING HARNESS TO VEHICLE. CAUTION: ALWAYS USE A FUSED(+) POSITIVE SUPPLY SOURCE. UNDERCOAT SEAL FOR HARSH WEATHER.

- HINT:** Molded Step Boards: For longevity, check rubber seals before installation. Rubber grommets around red and blue wires going into rear sockets, should be inserted and recessed about 1/4". **NOTE:** Remove bulbs and apply white grease into sockets and replace bulbs. Apply RTV Silicone where lights go into socket. Install lights and run wire loom as shown. **SEE FIGURE 9.** For Sure-Grip Running Boards, run wire loom down center as shown. **SEE FIGURE 8.**
- STEP 8. Determine whether your vehicle has a positive or negative switching courtesy system or an auxiliary light source (most Fords). Obtain an accurate wiring diagram for your vehicle's courtesy light system.
For positive and negative switching:
 Locate a pass-through point (usually under carpet at driver side door sill) for the wire harness. Locate main courtesy wire (usually wire lead to dome light). **NOTE:** If you do not use the main courtesy wire, lights will only function when one door is open. Route wire harness so that the 2 female connections (from step board) are nearest to pass thru point.*Connect opposite step board lead to either connection. Connect the splicing lead to remaining female socket and route one wire thru pass thru point. **SEE FIGURE 12.**

VERY IMPORTANT - Double check that your system has positive or negative switching.
For positive switching only: Connect positive wire to main courtesy system, (usually wire lead to dome light). TEST CONTINUITY BEFORE CONNECTING BY OPENING AND CLOSING ALL DOORS. Ground remaining wire.
For negative switching only: Connect negative wire to main courtesy system, (usually wire lead to dome light but sometimes from dome light to courtesy ECU). TEST GROUND CONTINUITY BEFORE CONNECTING BY OPENING AND CLOSING ALL DOORS.

Connect remaining wire to battery using a 5A fuse.

**Be sure that you have not routed any wires near moving parts (i.e.. driveshaft) or near any heat generating source (i.e.. transmission, engine, exhaust).

Auxiliary Light source:

Locate auxiliary light source connection under vehicle (usually attached to back side of front or rear fender well (refer to vehicles owners manual). **SEE FIGURE 12.** TEST SOURCE BEFORE CONNECTING. Connect splicing leads to aux light source. test step board lights for proper function by opening and closing doors.

STEP 9. Under-coat board, brackets and electrical wires, connections and lenses for harsh weathor conditions. Reinstall plastic cover on underside of Step boards. **INSTALLATION IS COMPLETE.**

FINISH PROTECTION

Westin products have a high quality finish that must be cared for like any other exposed finish on the vehicle. Protect the finish with a non-abrasive automotive wax, (e.g. Pure Carnauba) on a regular basis. The use of any soap, polish or wax that contains an abrasive is detrimental, as the compounds scratch the finish and open it to corrosion.

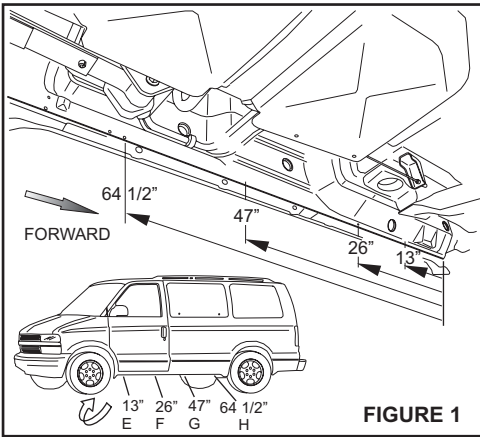

FIGURE 1

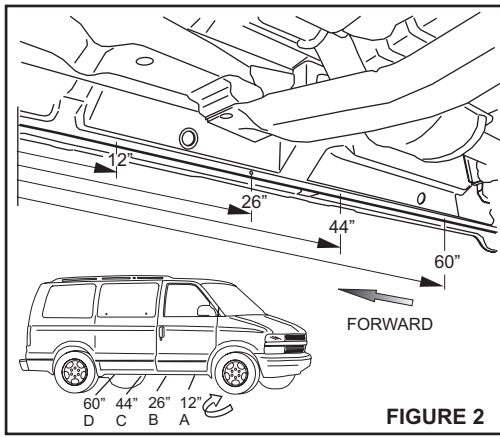

FIGURE 2

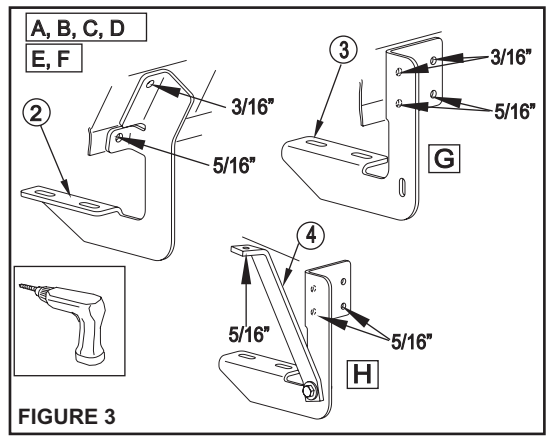

FIGURE 3

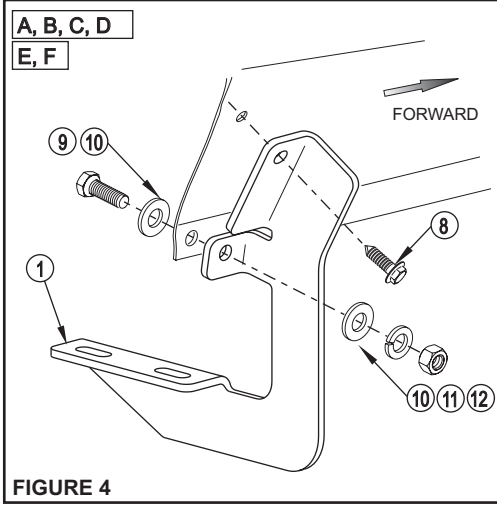

FIGURE 4

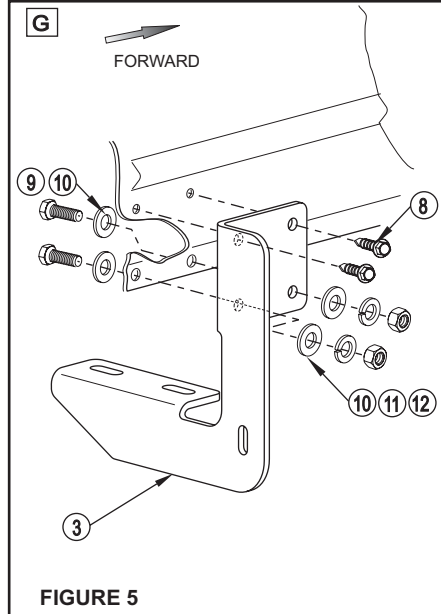

FIGURE 5

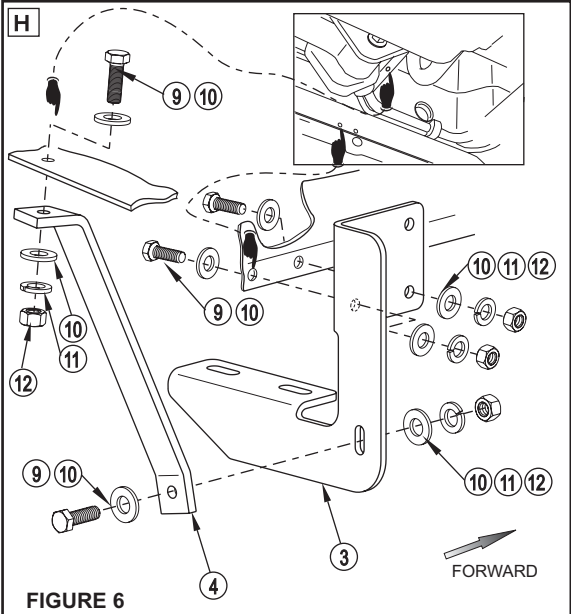

FIGURE 6

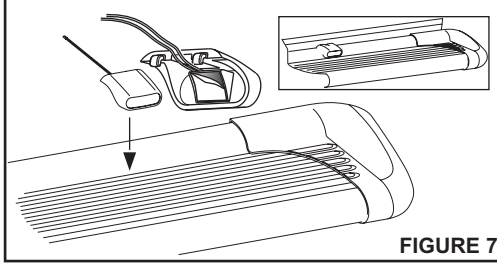

FIGURE 7

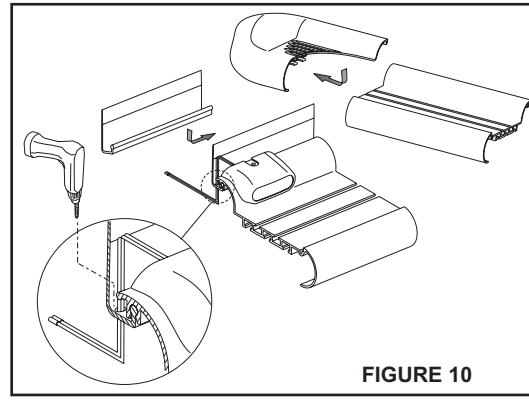

FIGURE 10

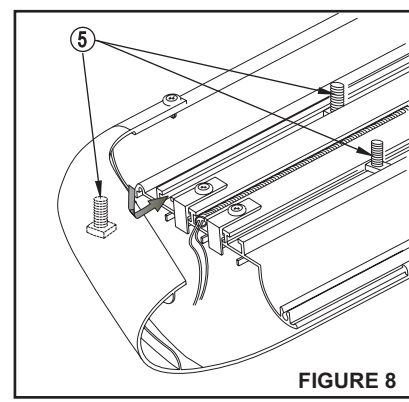

FIGURE 8

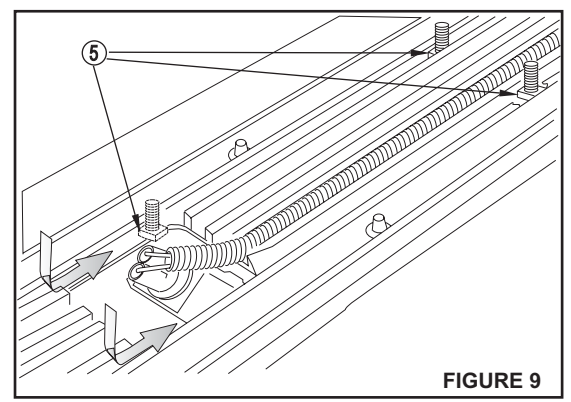

FIGURE 9

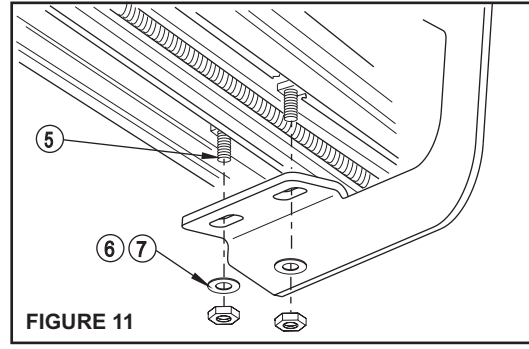

FIGURE 11

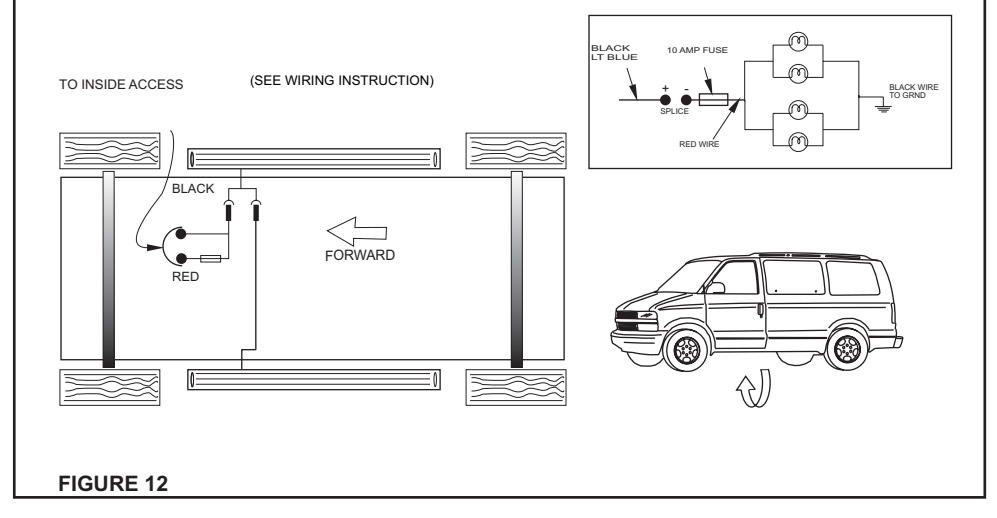

FIGURE 12