



SIGNATURE OF QUALITY

INSTALLATION INSTRUCTIONS

APPLICATION: 2005-08 NISSAN FRONTIER KING CAB/CREW CAB
2005-08 NISSAN XTERRA

AUTOMOTIVE PRODUCTS, INC.

STEP BAR ASSEMBLIES

25-2730	25-2735	
25-2750	25-2755	26-2750
25-3470	25-3475	26-3470

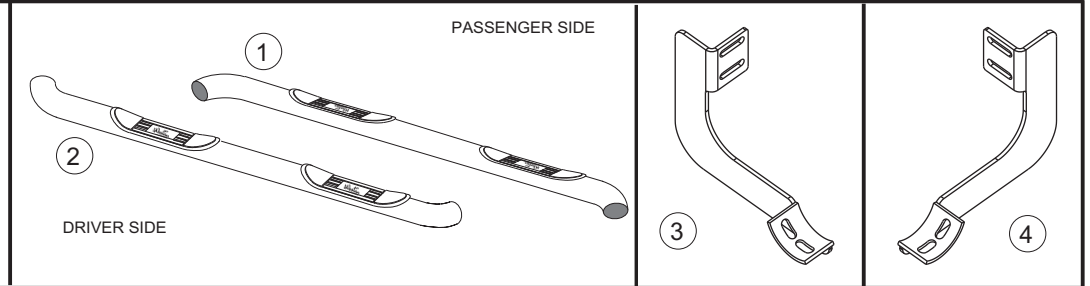

ITEM	QTY	CONTENTS	TOOLS
1,2	2	STEP BAR, PASSENGER (1) AND DRIVER (2)	13MM SOCKET 13MM WRENCH 7/32" HEX WRENCH RATCHET TORQUE WRENCH
3	3	MOUNT FRONT PASSENGER/REAR DRIVER	
4	3	MOUNT FRONT DRIVER/ REAR PASSENGER	
5	12	3/8-16 X 1.00" BUTTON HEAD BOLT	
6	12	3/8" INTERNAL TOOTH LOCK WASHER	
7	12	M8 FLAT WASHER	
8	12	M8-1.25 HEX REVERSIBLE LOCK NUT	

- STEP 1. Remove contents from box and check for damage. Verify all parts are present. Read instructions completely before beginning.
- STEP 2. Determine bracket locations for passenger front/driver rear and driver front/passenger rear brackets. **SEE FIGURES 1 AND 2.**
- STEP 3. Locate passenger side mounting locations on vehicle. Attach mount brackets to rocker panel. Leave loose. **SEE FIGURE 2.**
- STEP 4. Attach passenger side step bar to cradles with the Westin logo facing outward as shown. Assemble with 3/8" fasteners. Leave loose. **SEE FIGURES 2 AND 3.** The step pad closest to the bend goes to the rear of the vehicle.
- STEP 5. Make sure step bar and brackets are properly aligned with vehicle and tighten fasteners. Recommended torque values are 22 FT.LBS. for 8mm fasteners and 19 FT.LBS. for 3/8" fasteners.
- STEP 6. Repeat installation for opposite side.

FINISH PROTECTION

Westin products have a high quality finish that must be cared for like any other exposed finish on the vehicle. Protect the finish with a non-abrasive automotive wax, (e.g. Pure Carnauba) on a regular basis. The use of any soap, polish or wax that contains an abrasive is detrimental, as the compounds scratch the finish and open it to corrosion.

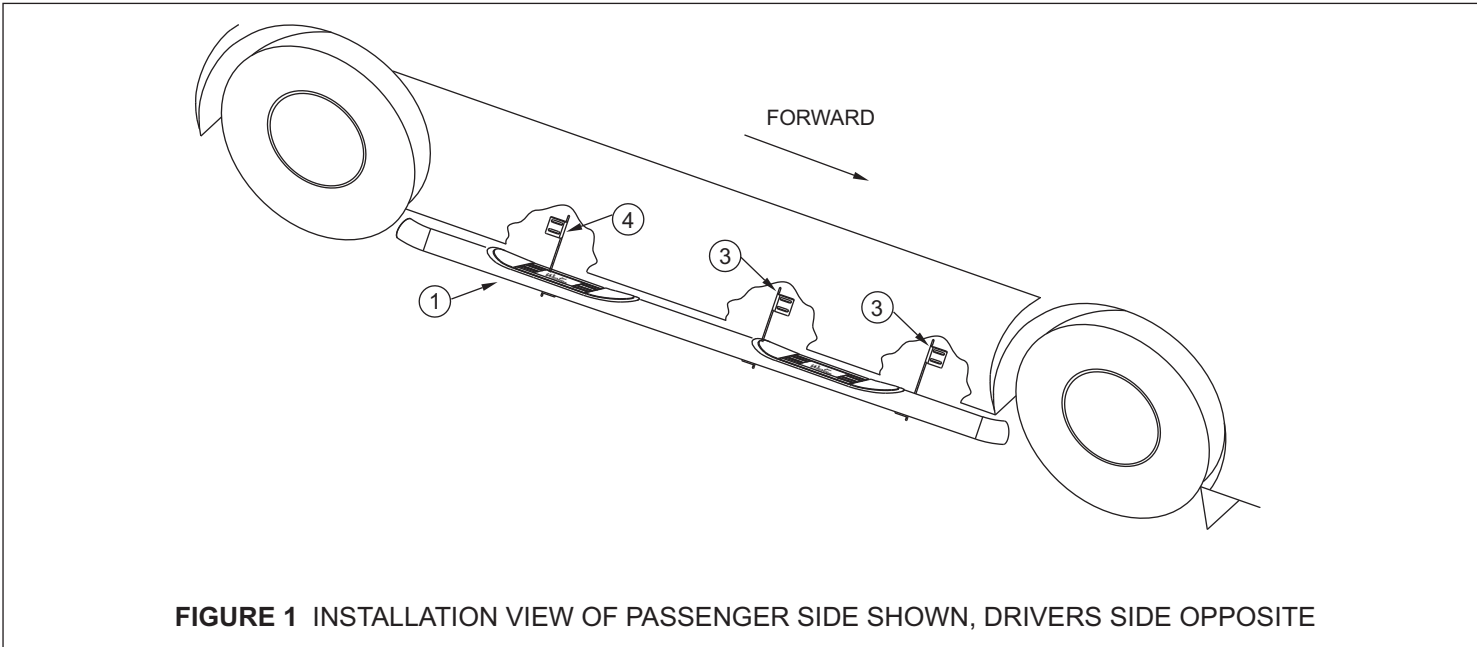

FIGURE 1 INSTALLATION VIEW OF PASSENGER SIDE SHOWN, DRIVERS SIDE OPPOSITE

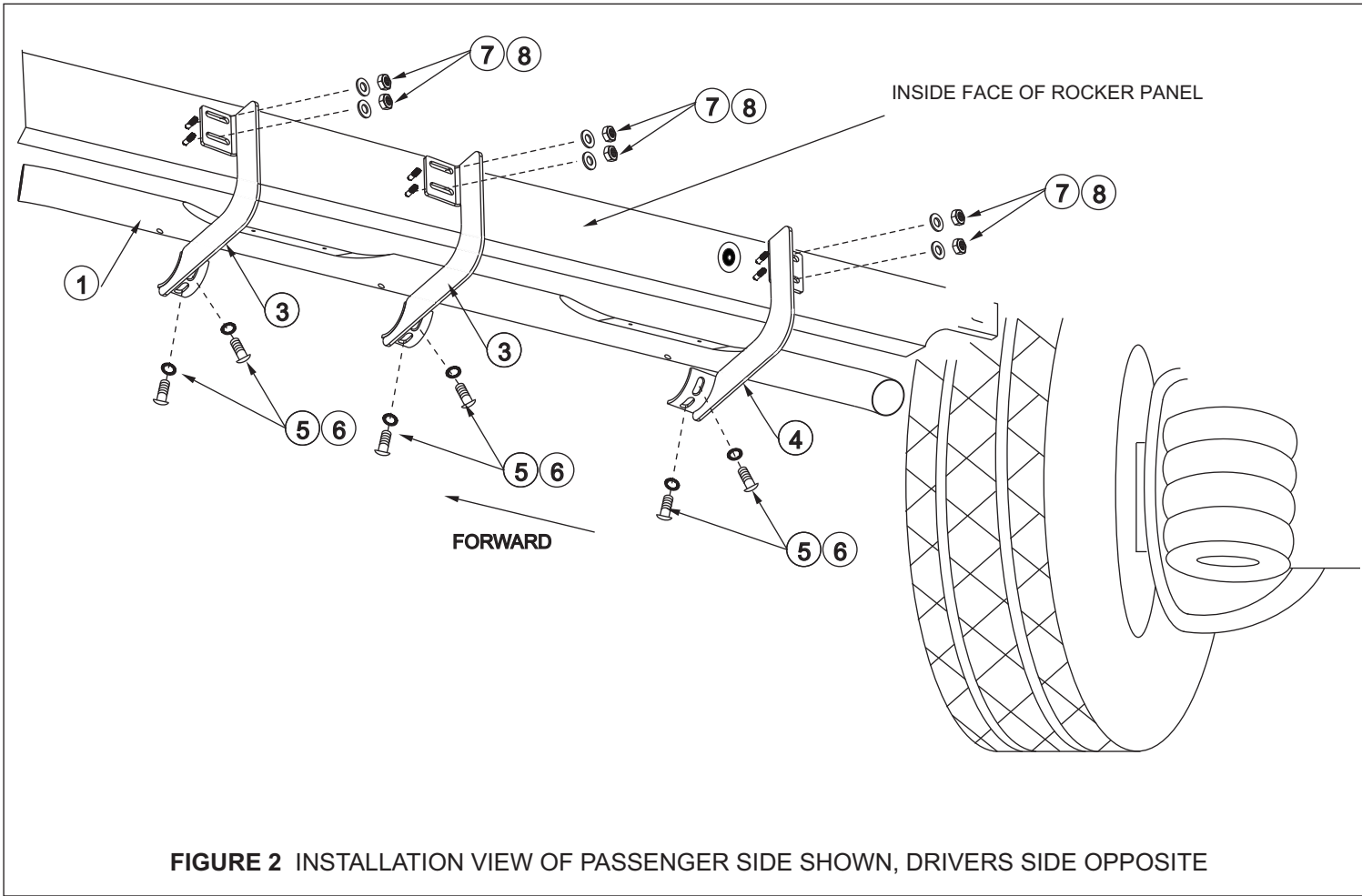

FIGURE 2 INSTALLATION VIEW OF PASSENGER SIDE SHOWN, DRIVERS SIDE OPPOSITE

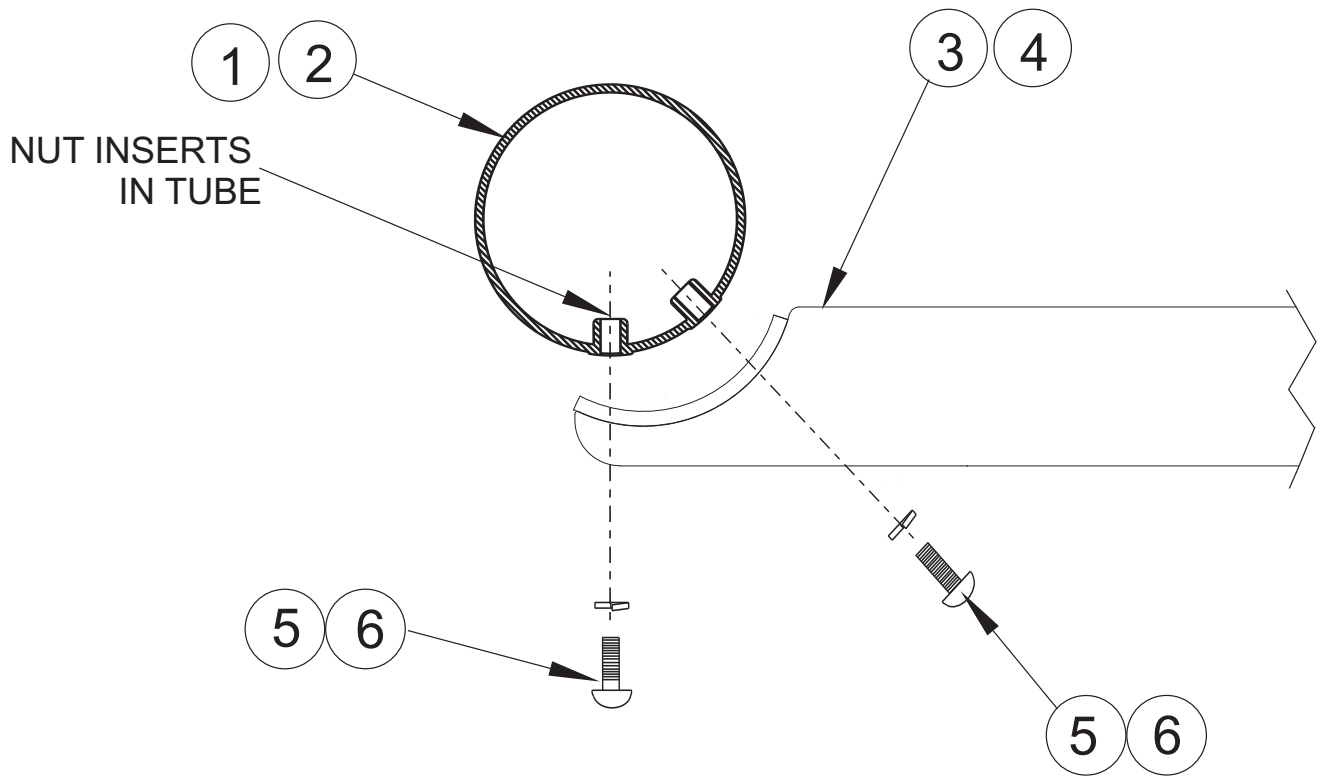

FIGURE 3 STEP BAR ATTACHMENT