



SIGNATURE OF QUALITY

AUTOMOTIVE PRODUCTS, INC.

INSTALLATION INSTRUCTIONS

APPLICATION: 1998-07 FORD RANGER/RANGER EDGE REG./EXT. CAB
1998-07 MAZDA B-SERIES PICKUP REG./EXT. CAB

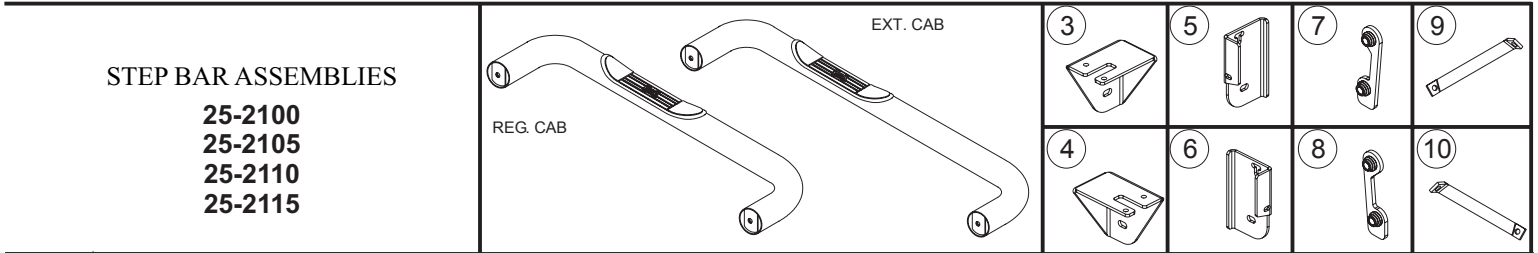

ITEM	QTY	CONTENTS	TOOLS
1,2	2	STEP BAR, PASSENGER (1) AND DRIVER (2)	3/4" SOCKET 9/16" SOCKET 9/16" WRENCH *7/16" DRILL BIT *DRILL CENTER PUNCH HAMMER RATCHET TORQUE WRENCH *NOTE: A SHORT 7/16" BIT WITH A 3/8" SHANK AND A SMALL OR RIGHT ANGLE DRILL MAY BE NECESSARY FOR EASIER INSTALLATION.
3,4	2	FRONT BRACKET, PASSENGER (3) AND DRIVER (4)	
5,6	2	REAR BRACKET, PASSENGER (5) AND DRIVER (6)	
7,8	2	MOUNT PLATE ASSEMBLY, PASSENGER (7) AND DRIVER (8)	
9,10	2	SUPPORT BRACE, PASSENGER (9) AND DRIVER (10)	
11	2	1/2-13 X 2.50" HEX HEAD BOLT	
12	2	1/2-13 X 2.00" HEX HEAD BOLT	
13	4	1/2" FLAT WASHER	
14	4	1/2" LOCK WASHER	
15	10	3/8-16 X 1.25" HEX HEAD BOLT	
16	16	3/8" FLAT WASHER	
17	10	3/8" LOCK WASHER	
18	6	3/8-16 HEX NUT	

- STEP 1.** Remove the contents from box and check for damage. Verify all parts are present. Read instructions completely before beginning.
- STEP 2.** Attach front brackets and support braces using 3/8" fasteners as shown. **SEE FIGURES 1 THROUGH 3.**
- STEP 3.** Temporarily attach rear bracket to vehicle through hole as shown. **SEE FIGURE 4.** Carefully cut out templates and align with visible portion of rear bracket. Tape template in place and mark center of top hole with center punch. Remove template and bracket from vehicle. Drill 7/16" diameter hole at this location.
NOTE: If hole on rocker panel aligns with T-Slot on mount bracket fasten at this location. Drilling is not required.
- STEP 4.** Attach rear brackets to the backside of rocker panel using 3/8" fasteners as shown. **SEE FIGURE 5.**
- STEP 5.** Attach step bars to brackets using 1/2" fasteners as shown. **SEE FIGURE 6.**
- STEP 6.** Make sure step bar and brackets are properly aligned with vehicle and tighten fasteners. Recommended torque value is 26 Ft. Lbs. for 3/8" fasteners and 64 Ft. Lbs. for 1/2" fasteners.

FINISH PROTECTION

Westin products have a high quality finish that must be cared for like any other exposed finish on the vehicle. Protect the finish with a non-abrasive automotive wax, (e.g. Pure Carnauba) on a regular basis. The use of any soap, polish or wax that contains an abrasive is detrimental, as the compounds scratch the finish and open it to corrosion.

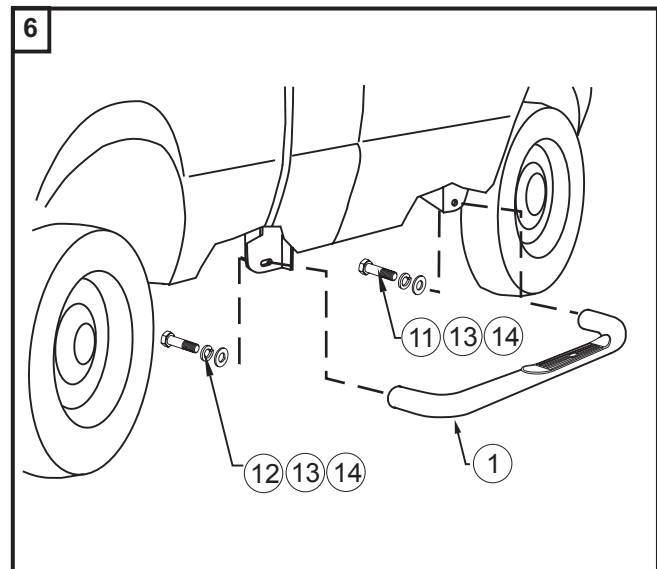
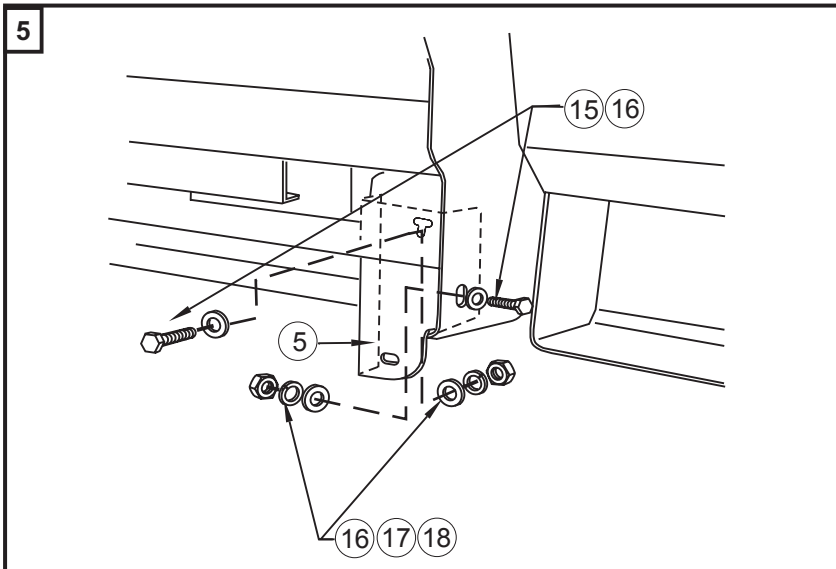
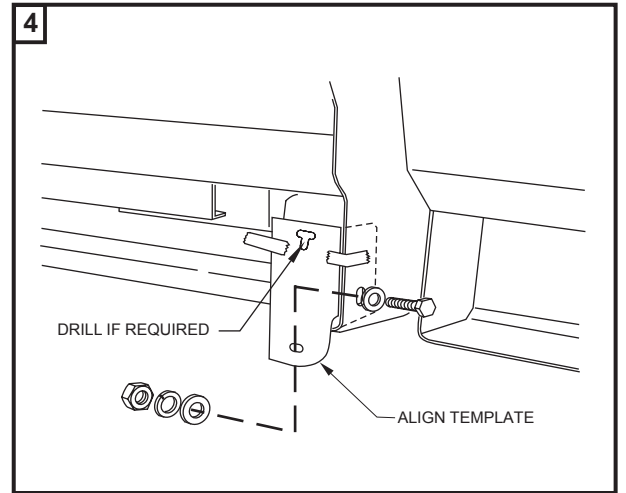
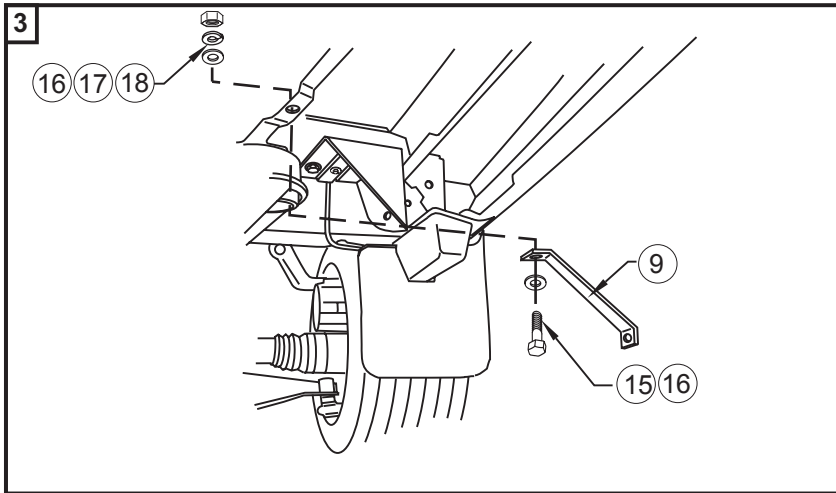
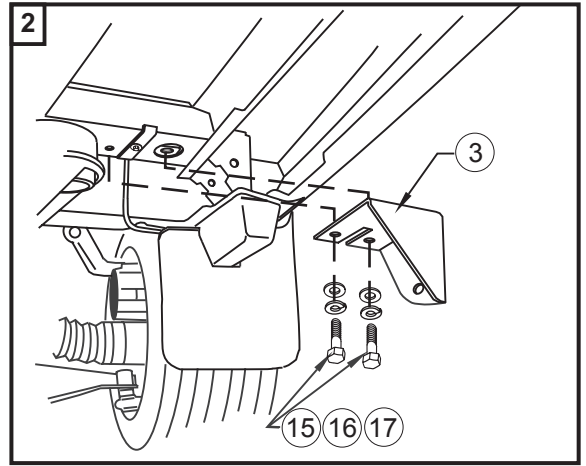
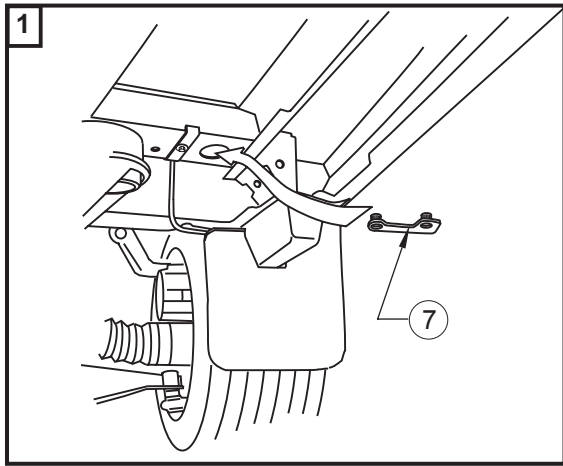

INSTALLATION VIEW OF PASSENGER SIDE SHOWN, DRIVER SIDE OPPOSITE