



SIGNATURE OF QUALITY

AUTOMOTIVE PRODUCTS, INC.

INSTALLATION INSTRUCTIONS

APPLICATION: 2001-UP TOYOTA TACOMA D-CAB 4DR

STEP BAR ASSEMBLIES

25-2010
25-2015
26-2010
26-2015

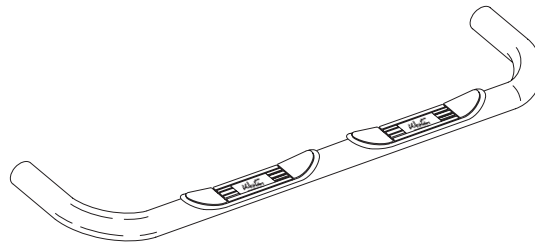

ITEM	QTY	CONTENTS	TOOLS
1	2	STEP BAR, PASSENGER AND DRIVER	3/4" SOCKET
2	2	FRONT BRACKET, PASSENGER AND DRIVER	3/4" WRENCH
3	2	REAR BRACKET, PASSENGER AND DRIVER	9/16" SOCKET
4	4	1/2-13 X 1.75" HEX HEAD BOLT	9/16" WRENCH
5	4	1/2" FLAT WASHER	17MM SOCKET
6	4	1/2" LOCK WASHER	RATCHET
7	4	3/8-16 X 1.00" HEX HEAD BOLT	TORQUE WRENCH
8	8	3/8" FLAT WASHER	
9	4	3/8" LOCK WASHER	
10	4	3/8-18 HEX NUT	
11	4	5/8" FLAT WASHER	
12	4	10MM FLAT WASHER	
13	4	M10-1.25" NYLOCK LOCK NUT	

- STEP 1. Remove the contents from box and check for damage. Verify all parts are present. Read instructions completely before beginning.
- STEP 2. Determine driver front and rear brackets.
- STEP 3. Attach front and rear bracket over body mount nut as shown. **NOTE:** Do not remove nut. Leave loose.
- STEP 4. Attach front and rear brackets to vehicle body using 3/8" fasteners as shown. Leave loose.
- STEP 5. Attach step bar to brackets using 1/2" fasteners as shown.
NOTE: Longer leg of step bar goes to rear of vehicle.
- STEP 6. Make sure step bar is properly aligned with vehicle. Torque 1/2" fasteners to 65 FT.LBS; 10mm fasteners to 32 FT.LBS. and 3/8" fasteners to 30 FT.LBS.

FINISH PROTECTION

Westin products have a high quality finish that must be cared for like any other exposed finish on the vehicle. Protect the finish with a non-abrasive automotive wax, (e.g. Pure Carnauba) on a regular basis. The use of any soap, polish or wax that contains an abrasive is detrimental, as the compounds scratch the finish and open it to corrosion.

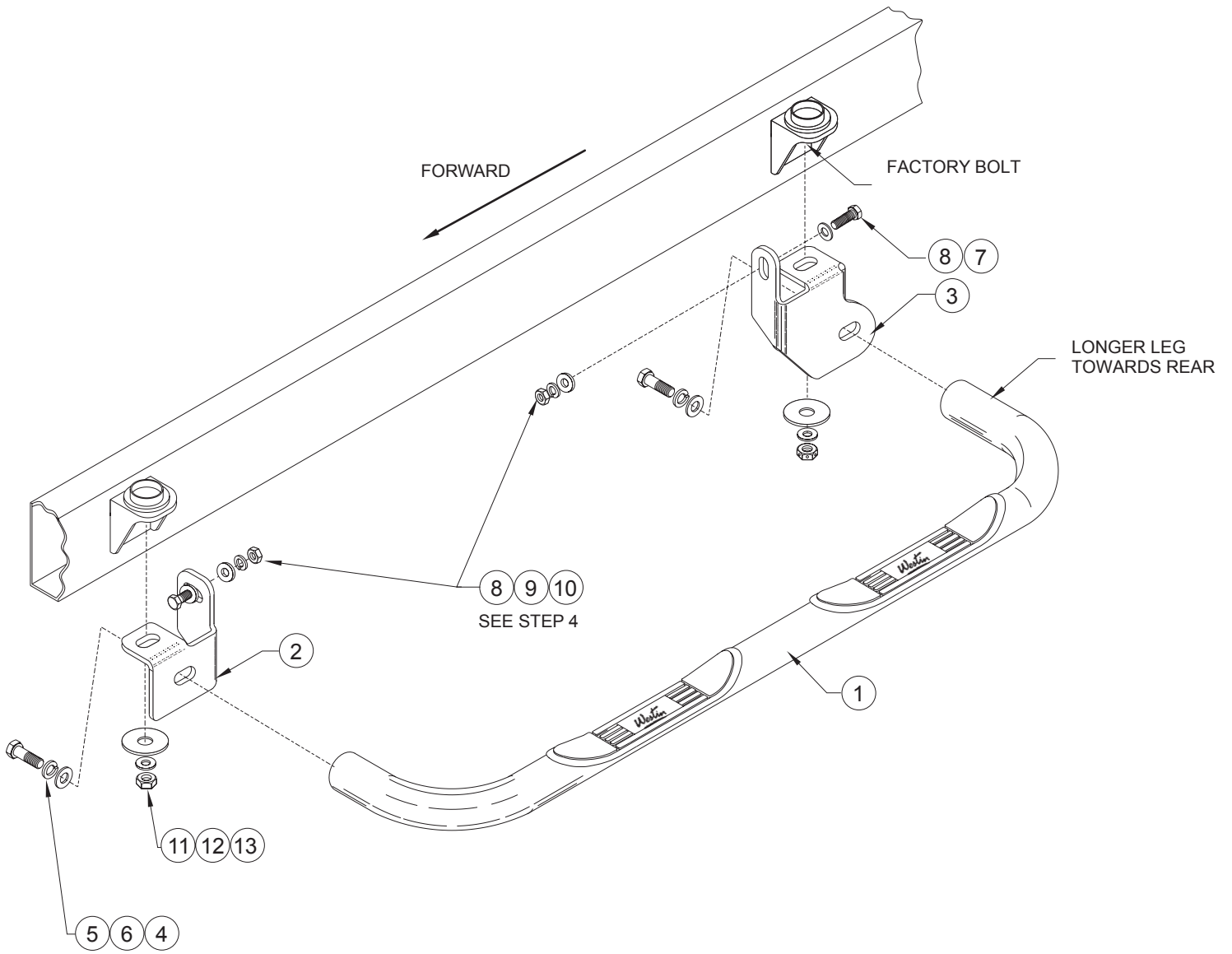

INSTALLATION VIEW OF DRIVER SIDE SHOWN, PASSENGER SIDE OPPOSITE