



SIGNATURE OF QUALITY

# INSTALLATION INSTRUCTIONS

APPLICATION: 1999-UP FORD F-250/350/450/550HD SUPERDUTY REGULAR CAB

AUTOMOTIVE PRODUCTS, INC.

STEP BAR ASSEMBLIES  
25-1320 25-1325

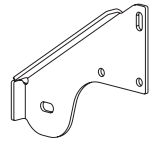
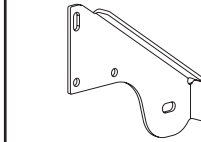
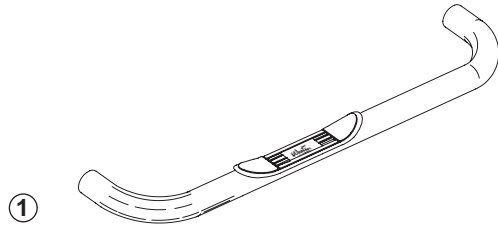

ITEM	QTY	CONTENTS	TOOL
1	2	STEP BAR, PASSENGER AND DRIVER	3/4" SOCKET 1/2" SOCKET 1/2" WRENCH TORQUE WRENCH RATCHET
2	2	FRONT DRIVER/REAR PASSENGER BRACKET	
3	2	FRONT PASSENGER/REAR DRIVER BRACKET	
4	4	1/2-13 X 2.00" HEX HEAD BOLT	
5	4	1/2" FLAT WASHER	
6	4	1/2" LOCK WASHER	
7	12	5/16-18 X 1.25" HEX HEAD BOLT	
8	20	5/16" FLAT WASHER	
9	12	5/16" LOCK WASHER	
10	8	5/16-18 HEX NUT	
11	4	5/16-18 CLIP NUT	

- STEP 1. Remove contents from box and check for damage. Verify all parts are present. Read instructions completely before beginning.
- STEP 2. Insert nut clips into rocker panel as shown. **SEE FIGURES 1 AND 2.**
- STEP 3. Install front and rear brackets as shown. Hand tighten. **SEE FIGURES 3 AND 4.**
- STEP 4. Attach step bar to brackets. Make sure step bar and brackets are properly aligned. Tighten and torque 1/2" fasteners to 65 Ft. Lbs; 5/16" fasteners to 30 Ft. Lbs. **SEE FIGURE 5.**

### FINISH PROTECTION

Westin products have a high quality finish that must be cared for like any other exposed finish on the vehicle. Protect the finish with a non-abrasive automotive wax, (e.g. Pure Carnauba) on a regular basis. The use of any soap, polish or wax that contains an abrasive is detrimental, as the compounds scratch the finish and open it to corrosion.

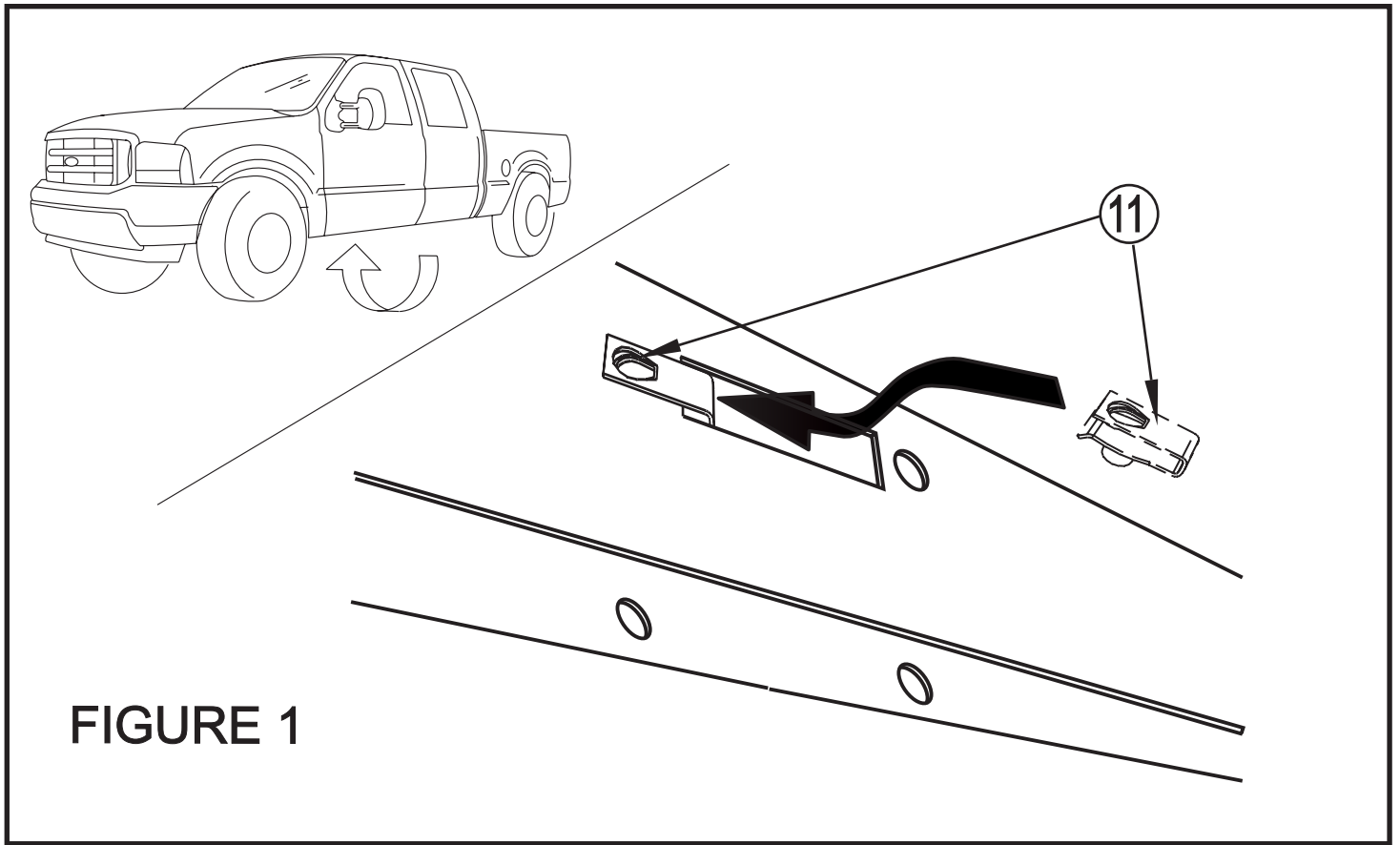

**FIGURE 1**

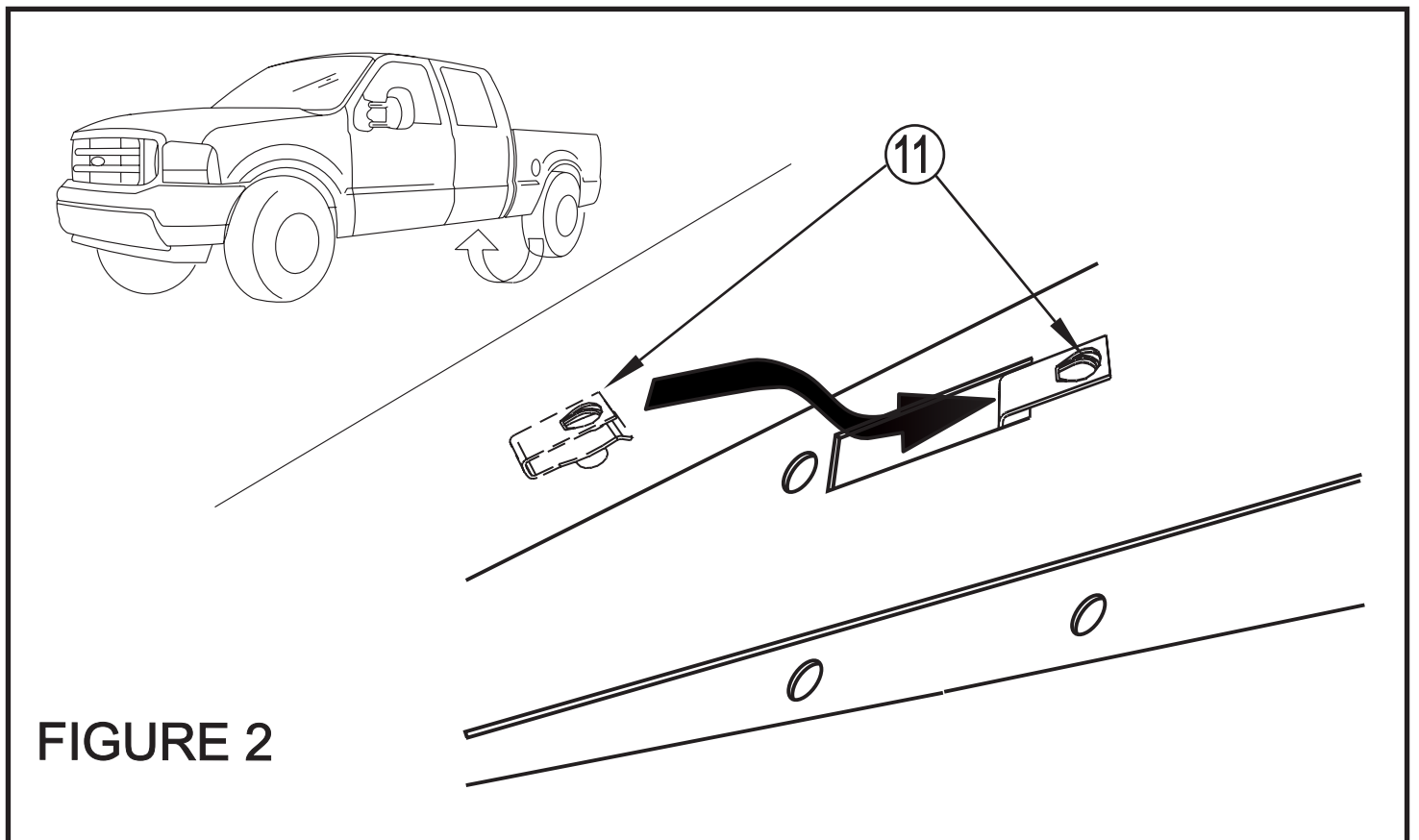

**FIGURE 2**

