



INSTALLATION INSTRUCTIONS

Platinum Oval Wheel to Wheel Step Bar Set - Cab Mount Style

APPLICATION: 2007-2013 Chevrolet Silverado & GMC Sierra 1500 Extended Cab w/Long Box (8')
 2008-2014 Chevrolet Silverado & GMC Sierra 2500/3500 Extended Cab w/Long Box (8')
 2008-2014 Chevrolet Silverado & GMC Sierra 2500/3500 Crew Cab w/Long Box (8')
 2015+ Chevrolet Silverado & GMC Sierra 2500/3500 Double Cab w/Long box (8')
 2015+ Chevrolet Silverado & GMC Sierra 2500/3500 Crew Cab w/Long box (8')

PART NUMBER: 24-54190/95, 24-54210/15
 24-54570/75, 24-54590/95

ITEM	QUANTITY	DESCRIPTION	TOOLS NEEDED
1	1	DRIVER SIDE STEP BAR (CLEAR WRAPPING)	21MM SOCKET
2	1	PASSENGER SIDE STEP BAR (PINK WRAPPING)	3/4" SOCKET
3	2	FRONT MOUNTING BRACKET, (FOR 2015+)	18MM SOCKET
3	1	DRIVER SIDE FRONT MOUNTING BRACKET, (FOR 2007-2013)	13MM SOCKET
4	1	PASSENGER SIDE FRONT MOUNTING BRACKET, (FOR 2007-2013)	RATCHET
5	1	DRIVER SIDE CENTER MOUNTING BRACKET	TORQUE WRENCH
6	1	PASSENGER SIDE CENTER MOUNTING BRACKET	1/8" DRILL BIT
7	1	DRIVER SIDE REAR CAB MOUNTING BRACKET	11/16" TO 3/4" DRILL BIT
8	1	PASSENGER SIDE REAR CAB MOUNTING BRACKET	
9	1	DRIVER SIDE REAR BED MOUNT TOP BRACKET	DRILL MOTOR
10	1	PASSENGER SIDE REAR BED MOUNT TOP BRACKET	
11	1	DRIVER SIDE REAR BED MOUNT LOWER BRACKET	
12	1	PASSENGER SIDE REAR BED MOUNT LOWER BRACKET	
13	2	BED MOUNT ISOLATOR TOP	
14	2	BED MOUNT ISOLATOR LOWER	
15	2	BED MOUNT ISOLATOR WASHER	
16	2	BED MOUNT ISOLATOR M12 CAP SCREW	
17	2	1/2" X 2" HEX CAP SCREWS	
18	2	1/2" LOCK WASHERS	
19	2	1/2" FLAT WASHERS	

CARE INSTRUCTIONS

- REGULAR WAXING IS RECOMMENDED. DO NOT USE ANY TYPE OF POLISH OR WAX THAT MAY CONTAIN ABRASIVES
- STAINLESS STEEL PRODUCTS CAN BE CLEANED WITH MILD SOAP AND WATER. STAINLESS STEEL POLISH SHOULD BE USED TO POLISH SMALL SCRATCHES.
- GLOSS BLACK FINISHES SHOULD BE CLEANED WITH MILD SOAP AND WATER

ITEM	QUANTITY	DESCRIPTION
20	2	M12 STUD PLATES (FOR 07-10 ONLY)
21	2	M12 LOCK WASHERS (FOR 07-10 ONLY)
22	2	M12 FLAT WASHERS (FOR 07-10 ONLY)
23	2	M12 HEX NUT (FOR 07-10 ONLY)
24	12	M10 X 35MM BUTTON HEAD CAP SCREW (STAINLESS STEEL)
25	12	M10 FLAT WASHERS (STAINLESS STEEL)
26	12	M10 TOOTHED LOCK WASHERS (STAINLESS STEEL)
27	2	M8 X 40MM HEX CAP SCREW
28	2	M8 FLAT WASHER
29	2	M8 LOCK WASHER
30	2	M8 CLIP NUT (FOR 2015+ ONLY)
31	2	PLASTIC RETAINER (FOR 07-10 ONLY)

ANTI-SIEZE LUBRICAN MUST BE USED ON ALL STAINLESS STEEL FASTENERS T PREVENT THREAD DAMAGE AND GALLING

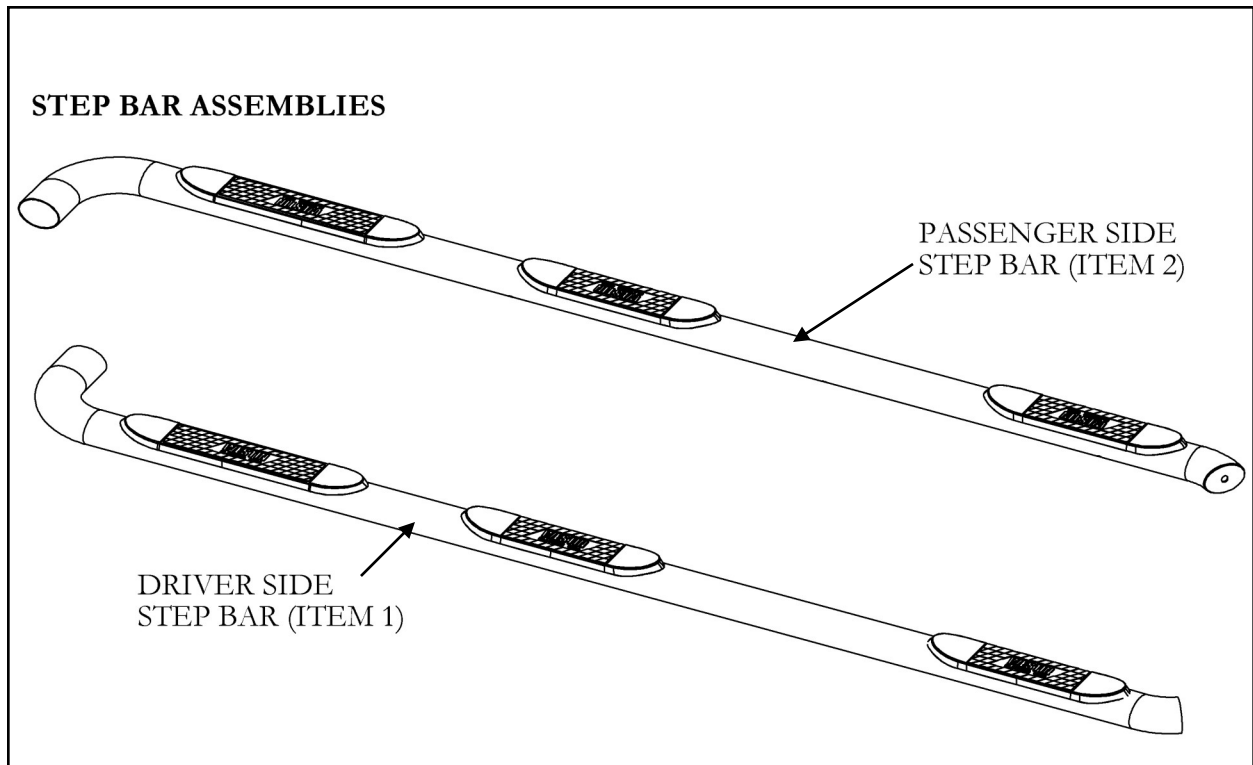

2007-2013 CAB MOUNTING BRACKETS

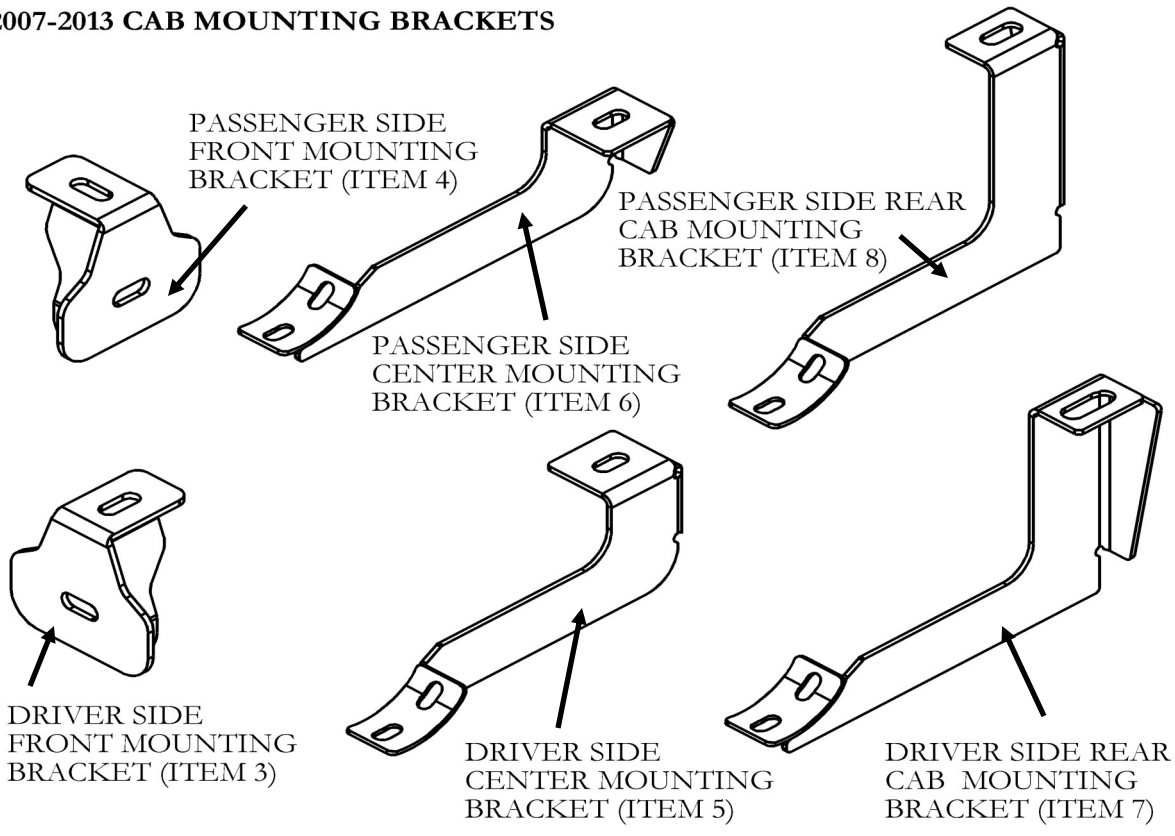

2015+ CAB MOUNTING BRACKETS

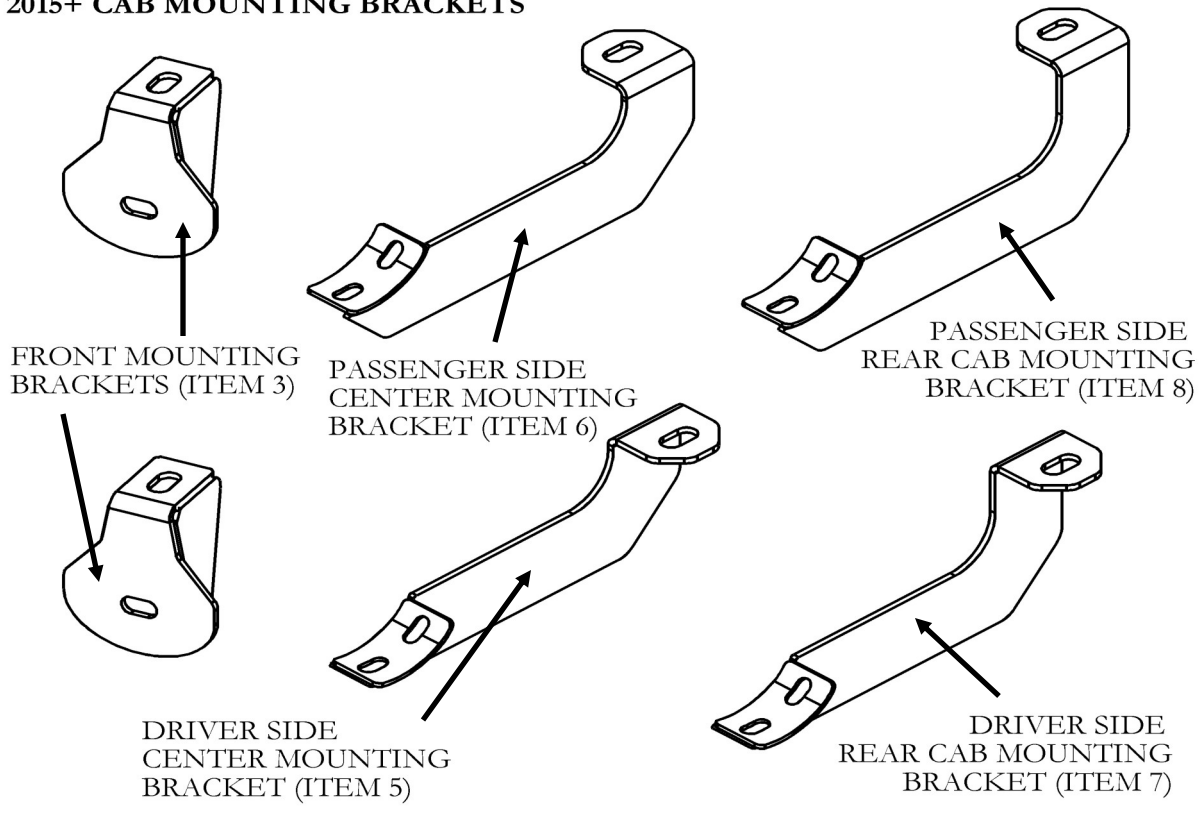

1. Remove contents from box, verify if all parts listed are present and free from damage. Carefully read and understand all instructions before attempting installation.

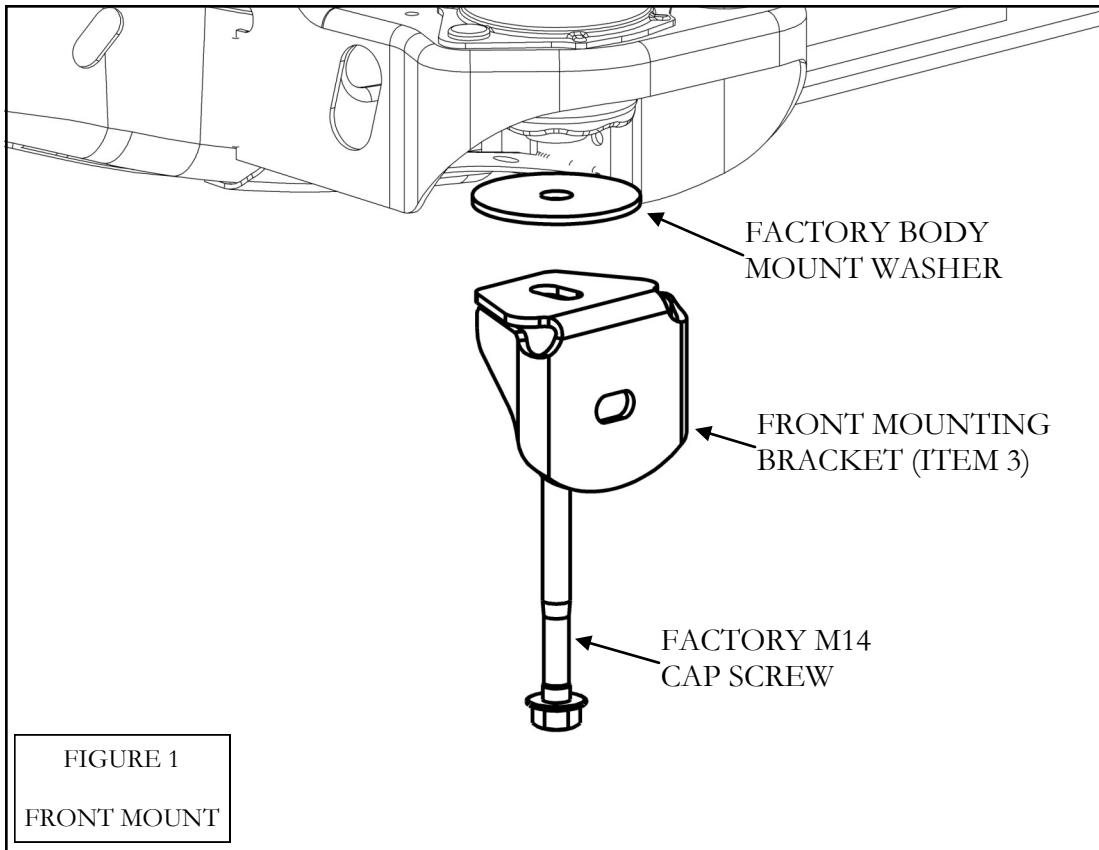

2. Start installation at the driver side. Locate the front cab mount. Remove the M14 body mount bolt from the cab mount. Install the front mounting bracket with the factory washer on the top side of the bracket. Do not fully tighten at this time. Figure 1

3. Repeat step 2 for the driver side center mounting bracket & the rear mounting bracket. Do not interchange the body mount bolts. They are sized specifically to each location.

4. Attach the driver side step bar assembly to the front mounting bracket using the provided 1/2" fasteners.
Figure 2

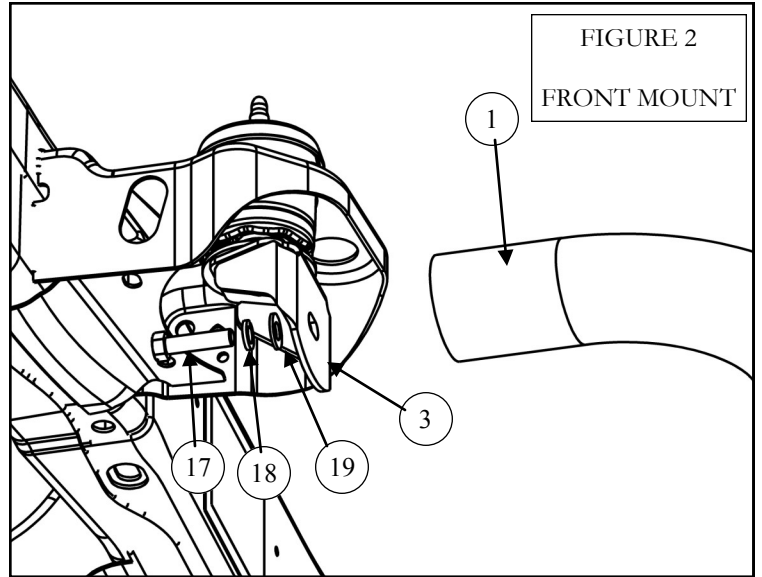

5. The center mounting bracket is attached to the step bar using the provided (x2) M10 button head screws, (x2) lock washers, then (x2) flat washers. Figure 3
6. Repeat step 5 for attaching the step bar to the rear mounting bracket. Figure 3

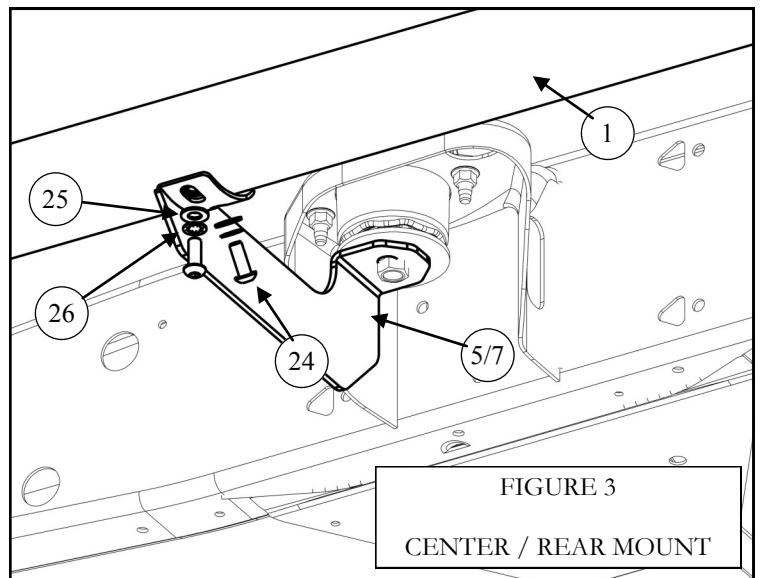

7. Locate the location for the driver side rear bed mount bracket (**Note: check for excess epoxy, and remove if necessary on the bed mounting location this can cause the rear bed mount bracket to not mount flush.**).

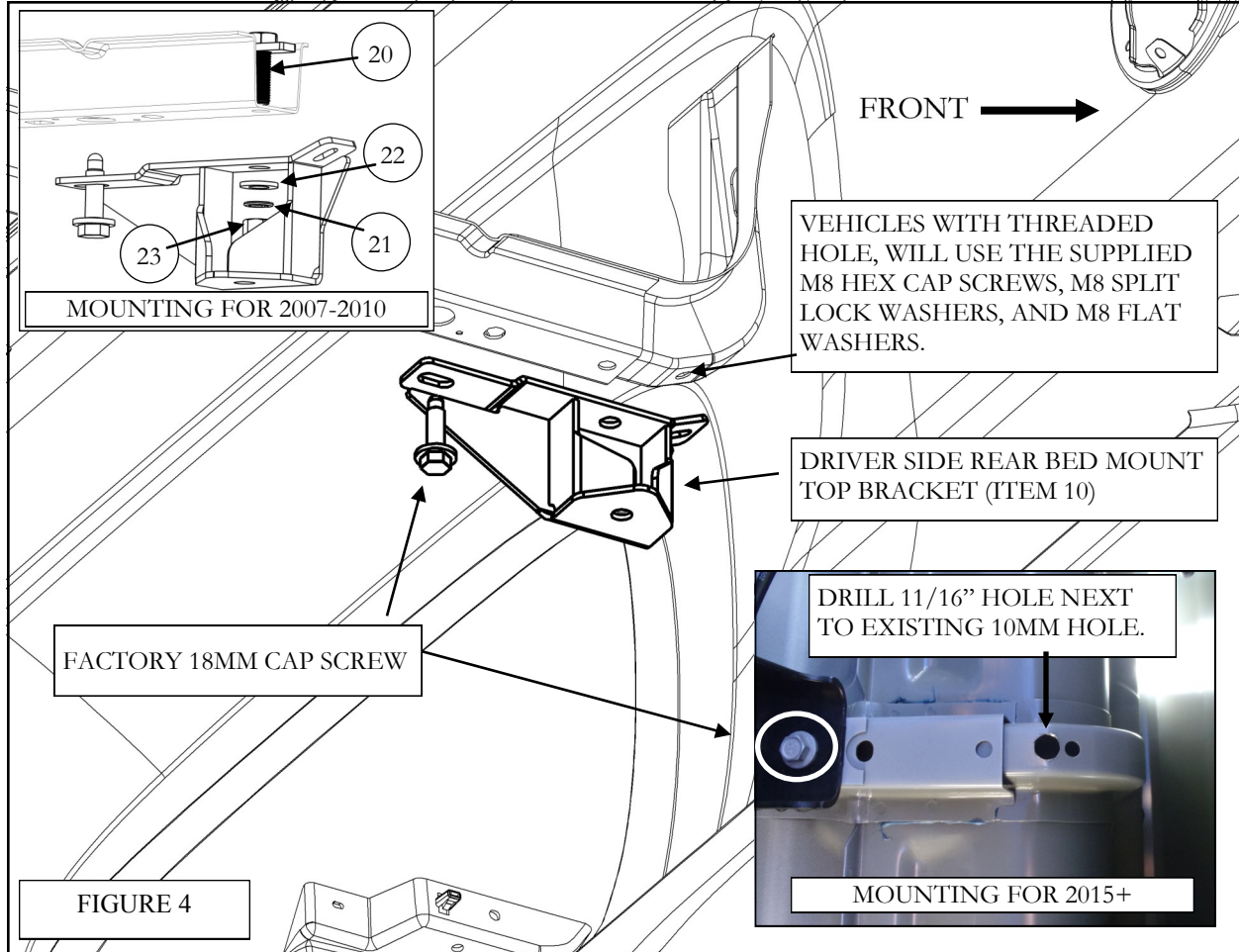

8. For 2011–2013 vehicles, remove the factory 18mm head bolt as shown in figure 4 and align the bed mount bracket (top) to the corresponding mount holes reinstall the factory hardware, and attach the front to the threaded insert in the bed mount location using (1) M8 hex head bolt , (1) M8 lock washer , and (1) M8 flat washer do not fully tighten at this time.

9. For 2007-2010 you must insert (1) M12 stud plate into the bed mount location channel. Then place (x1) plastic retainer on the stud plate to prevent it from moving attach using the provided (x1) M12 flat washer (x1) M12 lock washer, and (x1) M12 hex nut. Do not fully tighten at this time.

10. For 2015+ models, a hole must be drilled next to the existing 10mm hole on the bed mount channel. Use a small dill bit (1/8") to create a pilot hole approximately 1/2" away from the existing hole. Then use a larger bit (11/16"+) to enlarge the pilot hole. Apply some rust proofing paint to the bare metal edges before installing the mounting bracket. Insert one of the provided M8 clip nut through the larger hole so that the threads can be seen through the existing 10mm hole. The top bed bracket can now be installed using the provided M8 fasteners and the factory 18mm head bolt.

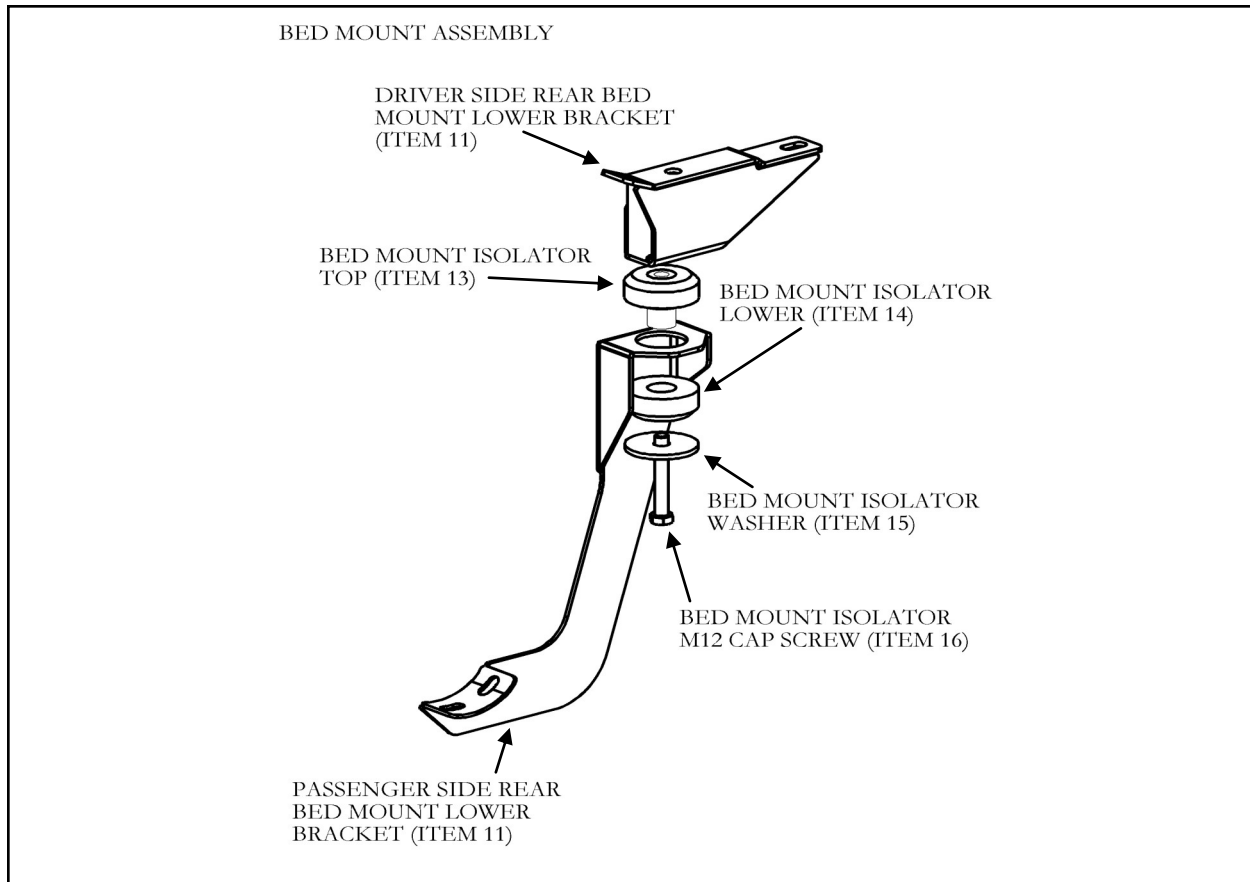

11. Assemble the bed bracket isolator and lower bed mount bracket to the installed top bracket as shown in figure 5.
12. Align the step bar and mounting brackets as desired. The recommended torque values for each fastener type are as follows. M14 body mount bolts to 95 ft-lbs, 1/2" fasteners to 65 ft-lbs, M12 fasteners to 55 ft-lbs, and the M10 fasteners to 25 ft-lbs.
13. Repeat installation steps for the passenger side.

INSTALLATION COMPLETE
2007 GMC SIERRA CREW CAB W/LONG BOX SHOWN



INSTALLATION COMPLETE
2015 GMC SIERRA DOUBLE CAB W/LONG BOX SHOWN

