



SIGNATURE OF QUALITY

AUTOMOTIVE PRODUCTS, INC.

# INSTALLATION INSTRUCTIONS

APPLICATION: 1999-13 FORD F-250/350/450/550 SUPER DUTY SUPER CAB AND CREW CAB

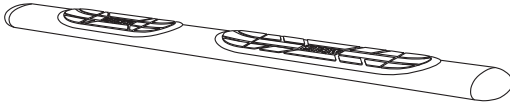
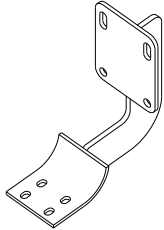
<p>MOUNT KIT  <b>22-1035</b>          CHROME  <b>22-5000, 22-5020, 22-5040</b>  <b>22-6000, 22-6020, 22-6040</b>          BLACK  <b>22-5005, 22-5025, 22-5045</b>  <b>22-6005, 22-6025, 22-6045</b></p>		
---	--	---

ITEM	QTY	CONTENTS	TOOLS
1	2	STEP BAR (PURCHASED SEPARATELY)	9/16" SOCKET 10MM SOCKET RATCHET TORQUE WRENCH
2	4	MOUNT BRACKET	
3	12	5/16-18 X 1.25" HEX HEAD BOLT	
4	20	5/16" FLAT WASHER	
5	12	5/16" LOCK WASHER	
6	8	5/16-18" HEX NUT	
7	4	EXTRUDED U-NUT	
8	4	M6 BOLT PLATE	
9	16	M6 FLAT WASHER	
10	16	M6 NYLOCK NUT	

- STEP 1. Remove contents from box and check for damage. Verify all parts are present. Read instructions completely before beginning.
- STEP 2. Install extruded u-nuts as shown. SEE FIGURE 1.
- STEP 3. Install front and rear brackets as shown. Hand tighten. SEE FIGURE 2.
- STEP 4. Attach step bars using M6 hardware SEE FIGURES 3, 4, AND 5.
- STEP 5. Make sure step bar and brackets are properly aligned and tighten fasteners. Recommended torque values are 15 FT.LBS. for 5/16" fasteners and 10 FT.LBS. for M6 fasteners.

### FINISH PROTECTION

Westin products have a high quality finish that must be cared for like any other exposed finish on the vehicle. Protect the finish with a non-abrasive automotive wax, (e.g. Pure Carnuba) on a regular basis. The use of any soap, polish or wax that contains an abrasive is detrimental, as the compounds scratch the finish and open it

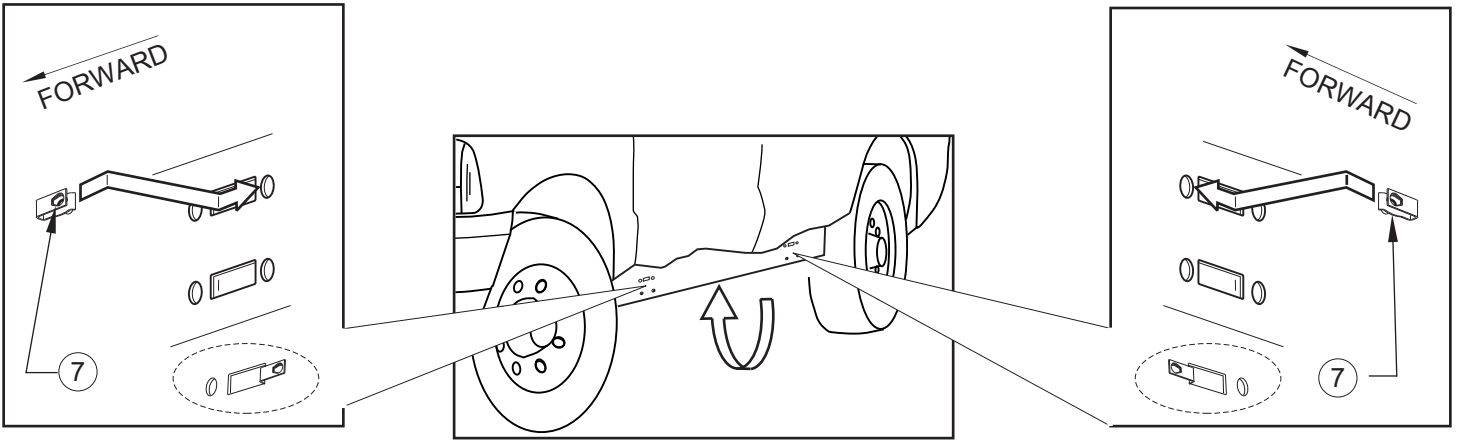

FIGURE 1 (DRIVER SIDE SHOWN)

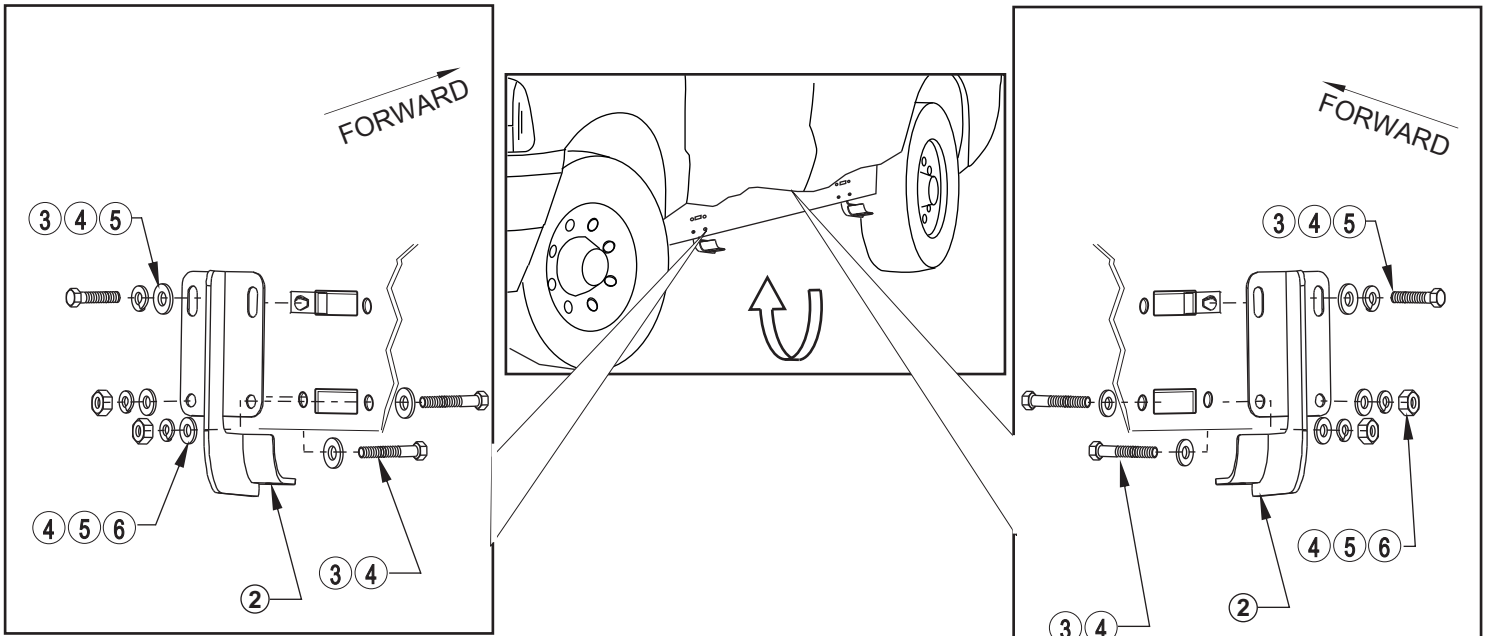

FIGURE 2 (DRIVER SIDE SHOWN)

