



SIGNATURE OF QUALITY

INSTALLATION INSTRUCTIONS

APPLICATION: 2005-07 NISSAN FRONTIER EXTENDED CAB, CREW CAB
2005-07 NISSAN XTERRA/PATHFINDER

AUTOMOTIVE PRODUCTS, INC.

MOUNT KIT
22-1525

FRONTIER EXT. CAB/XTERRA
22-0060, 22-0065, 22-5060, 22-5065
PATHFINDER
22-0050, 22-0055, 22-5050, 22-5055
FRONTIER CREW CAB
22-0020, 22-0025, 22-5020, 22-5025

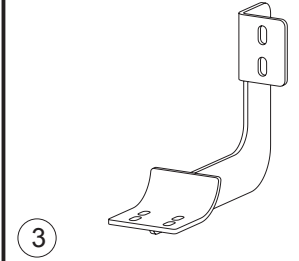
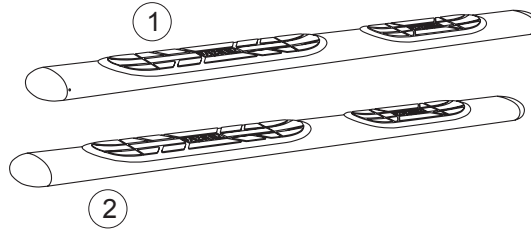

ITEM	QTY	CONTENTS	TOOLS
1,2	2	OVAL TUBE, PASSENGER (1) AND DRIVER (2) (PURCHASED SEPARATELY)	7/16" SOCKET
3	6	MOUNT BRACKET	7/16" WRENCH
4	12	M8-1.25 FLANGE NUT	10MM SOCKET
5	12	1/4-20 X .75 T-HEAD BOLT	10MM WRENCH
6	12	1/4" FLAT WASHER	RATCHET
7	12	1/4-20 NYLON INSERT LOCK NUT	TORQUE WRENCH

- STEP 1. Remove contents from box and check for damage. Verify all parts are present. Read instructions completely before beginning.
- STEP 2. Install brackets as shown. Hand tighten. **SEE FIGURE 1.**
- STEP 3. Slide T-head bolts on step bar as shown (3 per slot, 6 per bar). Place step bar on saddle with long step pad forward and end cap screw facing inward. Assemble with 1/4" fasteners. **SEE FIGURES 2 AND 3.**
- STEP 4. Make sure step bar and brackets are properly aligned with vehicle and tighten fasteners. Recommended torque values are 22 FT.LBS. for 8MM fasteners and 7 FT. LBS for 1/4" fasteners.
- STEP 5. Repeat for passenger side.

FINISH PROTECTION

Westin products have a high quality finish that must be cared for like any other exposed finish on the vehicle. Protect the finish with a non-abrasive automotive wax, (e.g. Pure Carnauba) on a regular basis. The use of any soap, polish or wax that contains an abrasive is detrimental, as the compounds scratch the finish and open it to corrosion.

EXISTING INSERT
IN BODY PANEL

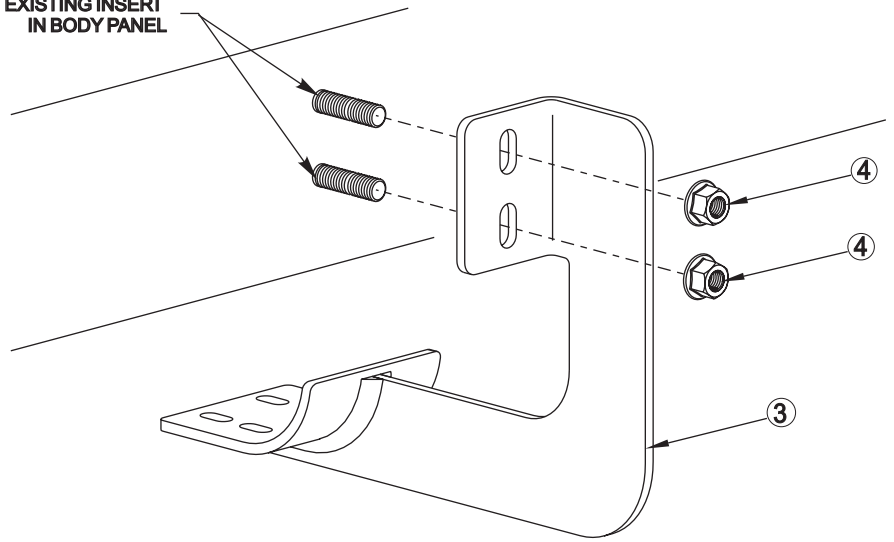

FIGURE 1

DRIVER SIDE

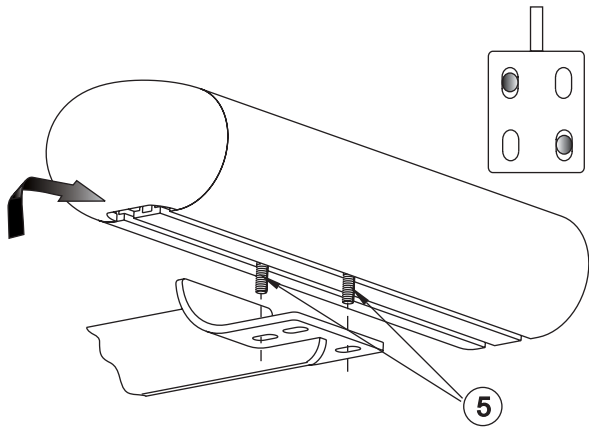

FIGURE 2

END CAP SCREW
(FACING INWARD)

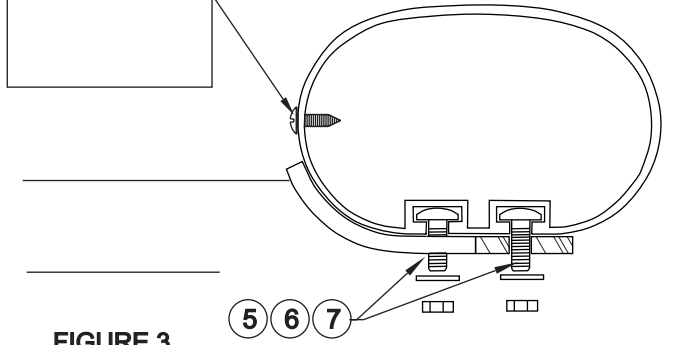

FIGURE 3