



SIGNATURE OF QUALITY

# INSTALLATION INSTRUCTIONS

APPLICATION: 2007-08 TOYOTA TUNDRA D-CAB & CREW MAX

AUTOMOTIVE PRODUCTS, INC.

MOUNT KIT <b>22-1665</b>  CHROME <b>22-0020, 22-0040</b>  BLACK <b>22-0025, 22-0045</b>			

ITEM	QTY	CONTENTS	TOOLS
1,2	2	STEP BAR, PASSENGER (1) AND DRIVER (2) (SOLD SEPARATELY)	13MM SOCKET 13MM WRENCH 7/16" SOCKET RATCHET TORQUE WRENCH
3	2	FRONT BRACKET	
4	2	FRONT/CENTER BRACKET	
5	2	REAR/CENTER BRACKET	
6	2	REAR BRACKET	
7	16	M8-1.25 X 30MM HEX HEAD BOLT	
8	16	3/8" FLAT WASHER	
9	16	3/8" LOCK WASHER	
10	16	1/4-20 X .75 T-HEAD BOLT	
11	16	1/4" FLAT WASHER	
12	16	1/4-20 NYLON INSERT LOCK NUT	

- STEP 1. Remove the contents from box and check for damage. Verify all parts are present. Read instructions completely before beginning.
- STEP 2. Determine front, front center, rear center and rear brackets. Rear/center bracket has 1 identification hole and rear bracket has 2 identification holes.
- STEP 3. Attach drivers side brackets to underside of body panel using two M8-1.25 x 30mm hex head bolts, 3/8" flat washers, and 3/8" lock washers per bracket. Hand tighten. **SEE FIGURE 1.**
- STEP 4. Slide T-head bolts on step bar as shown (4 per slot, 8 per bar). Place step bar on saddle with long step pad forward and end cap screw facing inward. Assemble with 1/4" fasteners. **SEE FIGURES 2 AND 3.**
- STEP 5. Make sure step bar and brackets are properly aligned with vehicle and tighten fasteners. Recommended torque values are 8mm fasteners to 22 FT.LBS. and 1/4" fasteners to 7 FT. LBS.
- STEP 6. Repeat installation for passenger side.

#### FINISH PROTECTION

Westin products have a high quality finish that must be cared for like any other exposed finish on the vehicle. Protect the finish with a non-abrasive automotive wax, (e.g. Pure Carnauba) on a regular basis. The use of any soap, polish or wax that contains an abrasive is detrimental, as the compounds scratch the finish and open it to corrosion.

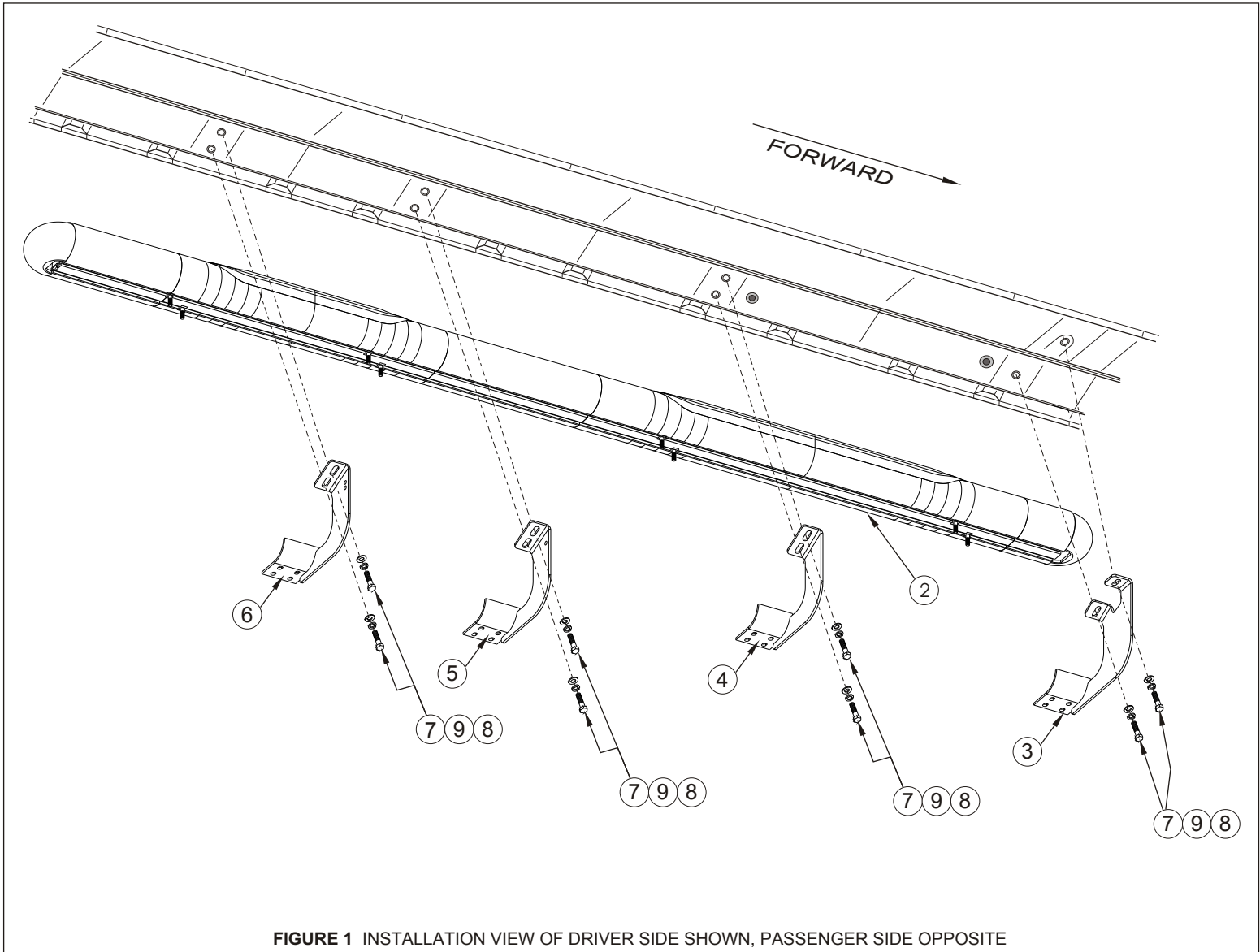

FIGURE 1 INSTALLATION VIEW OF DRIVER SIDE SHOWN, PASSENGER SIDE OPPOSITE

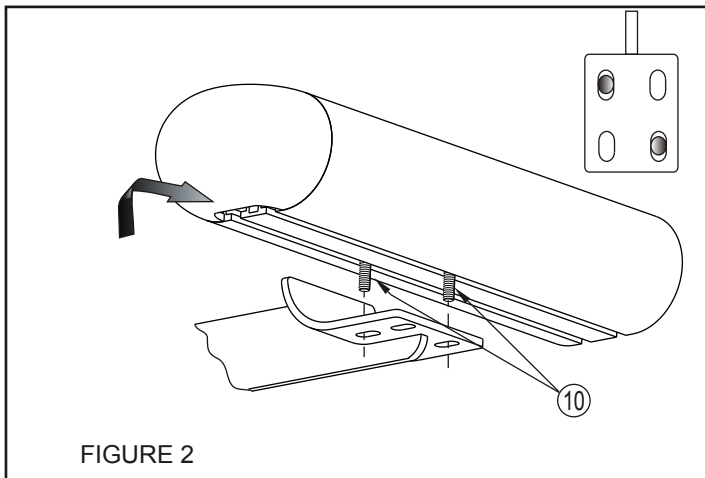

FIGURE 2

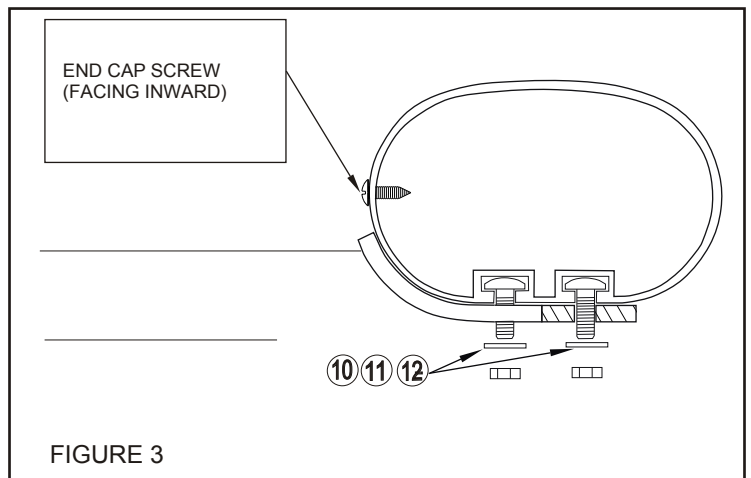

FIGURE 3