



SIGNATURE OF QUALITY

AUTOMOTIVE PRODUCTS, INC.

INSTALLATION INSTRUCTIONS

APPLICATION: 2005-07 JEEP GRAND CHEROKEE
2006-07 JEEP COMMANDER

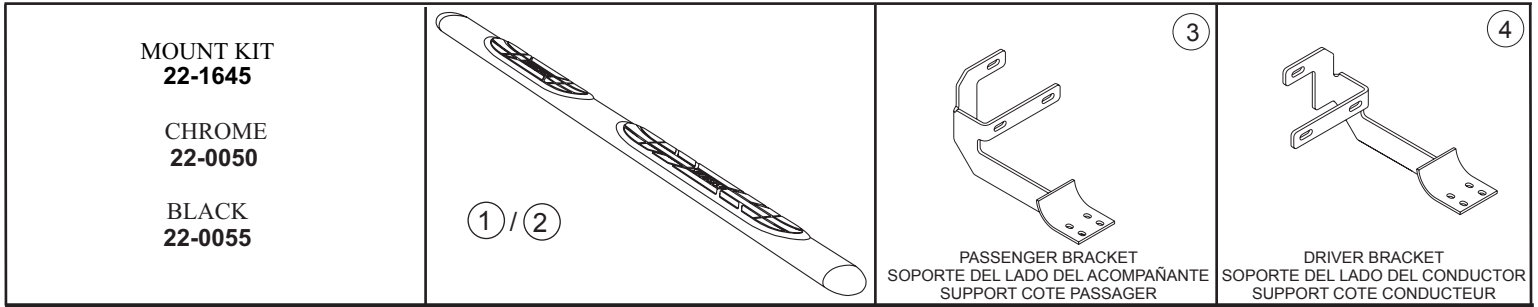

ITEM	QTY	CONTENTS	TOOLS
1,2	2	STEP BAR, PASSENGER (1) AND DRIVER (2)	TWO 13MM WRENCH 7/16" SOCKET RATCHET TORQUE WRENCH
3	2	PASSENGER BRACKET	
4	2	DRIVER BRACKET	
5	12	M8-1.25 X 30MM HEX HEAD BOLT	
6	20	8MM FLAT WASHER	
7	12	8MM LOCK WASHER	
8	8	M8-1.25 HEX NUT	
9	4	M8-1.25 EXTRUDED U-NUT	
10	8	1/4-20 X .75 T-HEAD BOLT	
11	8	1/4" FLAT WASHER	
12	8	1/4-20 NYLON INSERT LOCK NUT	

- STEP 1. Remove the contents from box and check for damage. Verify all parts are present. Read instructions completely before beginning.
- STEP 2. Determine passenger and driver brackets. Both front and rear brackets are the same for each side. **SEE CONTENTS FIGURE.**
- STEP 3. Locate driver side mounting locations on vehicle. **SEE FIGURE 1.**
- STEP 4. Attach driver side brackets to underside of rocker panel as shown. Hand tighten. **SEE FIGURES 1 AND 2. For Jeep Commanders only:** To attach the passenger side front bracket, remove the four bolts that secure the rear air and heat line shroud. Remove the shroud to gain access to top mounting location on the bracket. After bracket is installed and fasteners are tightened, reattach shroud with the four existing bolts previously removed. **SEE FIGURE 5.**
- STEP 5. Slide t-head bolts on step bar as shown (2 per slot, 4 per bar). Place step bar on saddle with long step pad forward and end cap screw facing inward. Assemble with 1/4" fasteners. **SEE FIGURES 3 AND 4.**
- STEP 6. Make sure step bar and brackets are properly aligned and tighten fasteners. Recommended torque values are 23 FT.LBS. for 8mm fasteners, 18.8 FT.LBS. for factory 8mm bolts and 7 FT.LBS. for 1/4" fasteners.
- STEP 7. Repeat installation for passenger side.

FINISH PROTECTION

Westin products have a high quality finish that must be cared for like any other exposed finish on the vehicle. Protect the finish with a non-abrasive automotive wax, (e.g. Pure Carnauba) on a regular basis. The use of any soap, polish or wax that contains an abrasive is detrimental, as the compounds scratch the finish and open it to corrosion.

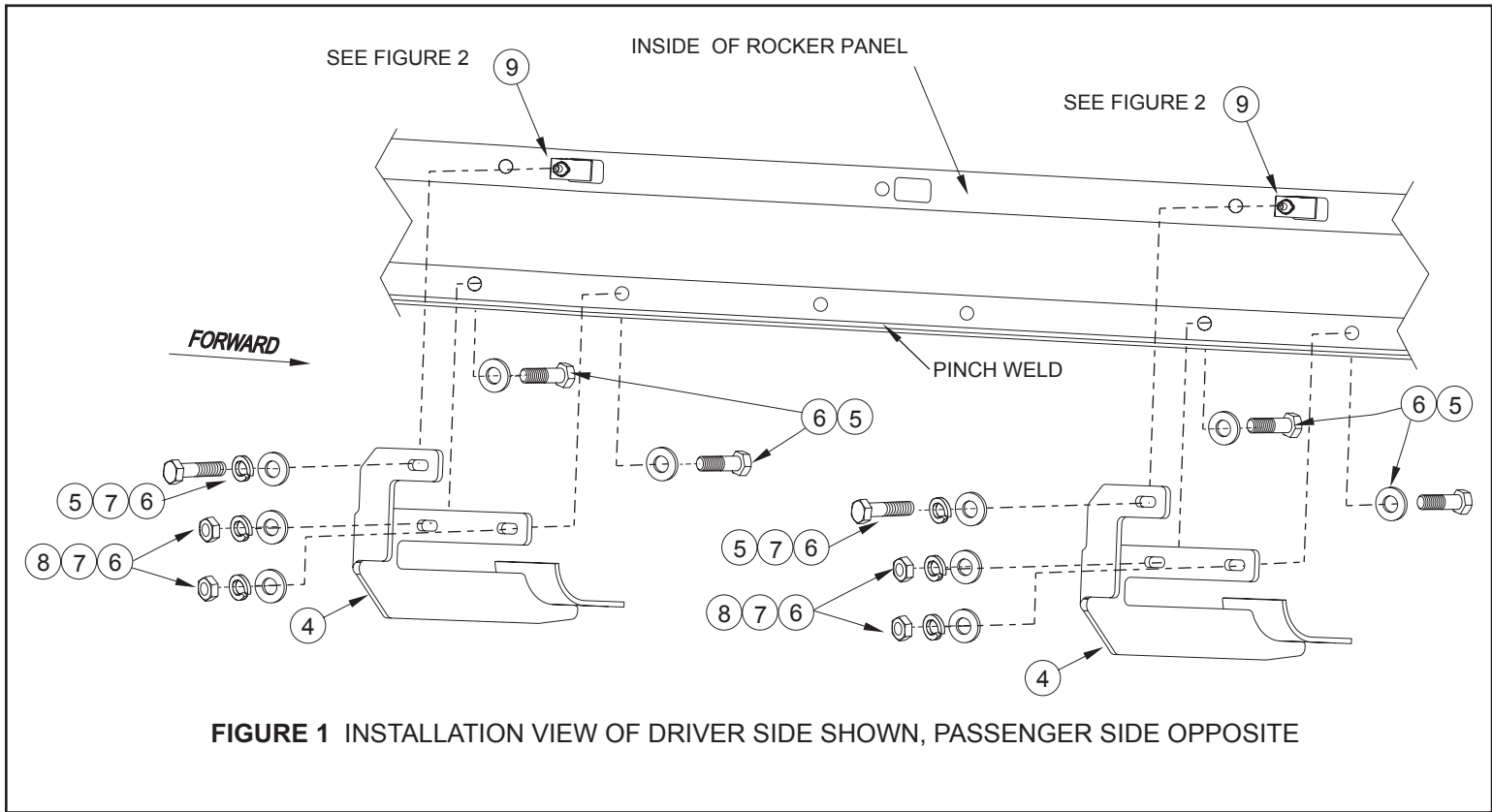
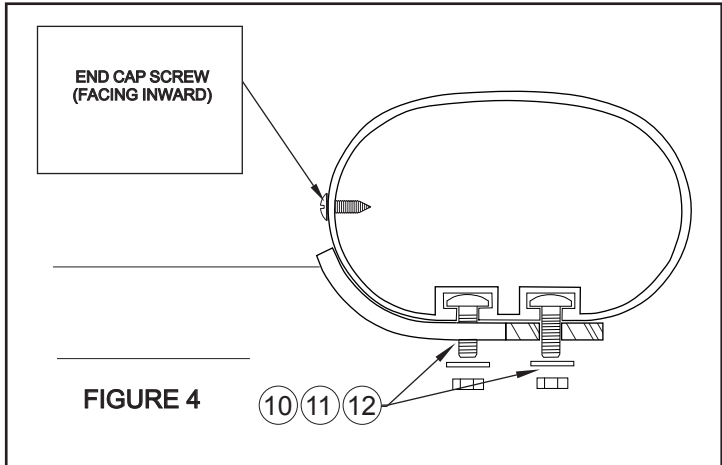
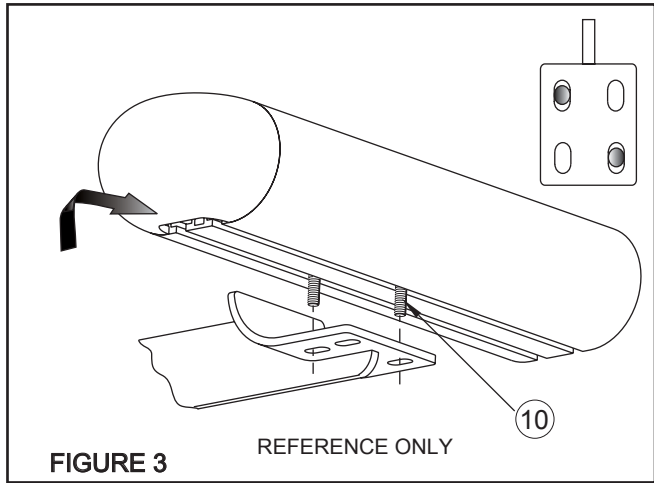
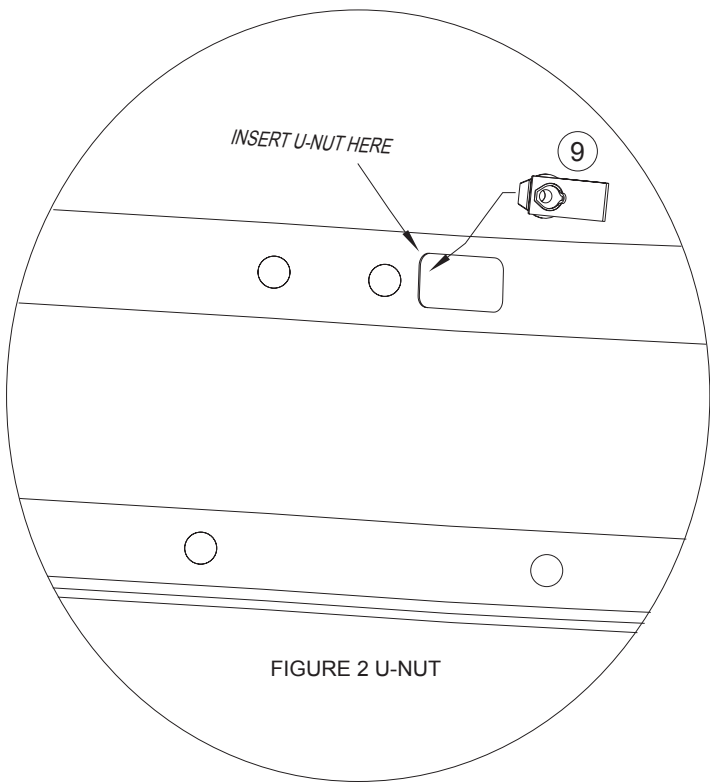

FIGURE 1 INSTALLATION VIEW OF DRIVER SIDE SHOWN, PASSENGER SIDE OPPOSITE



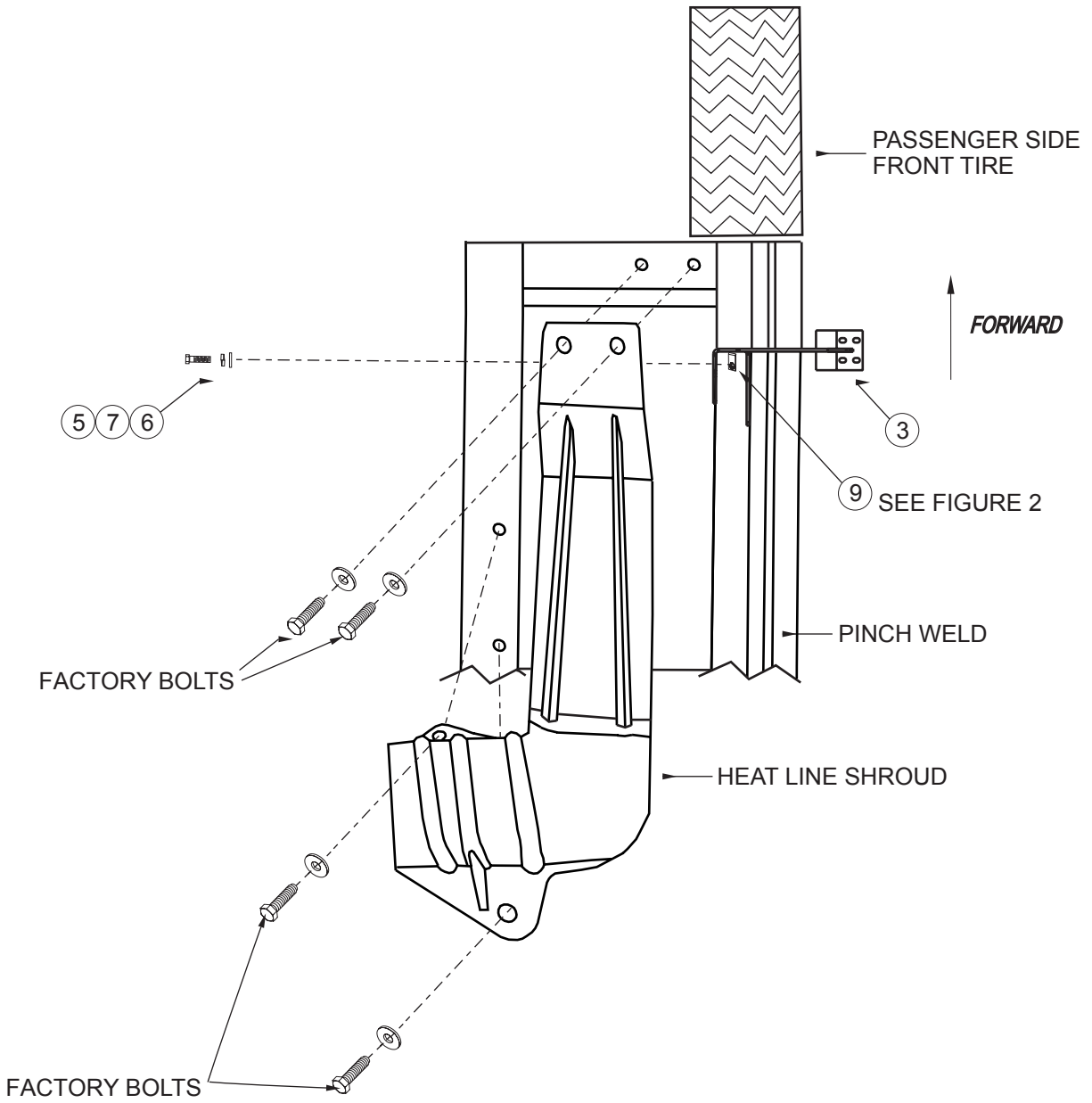

FIGURE 5