

# Westin

SIGNATURE OF QUALITY

AUTOMOTIVE PRODUCTS, INC.

## INSTALLATION INSTRUCTIONS

APPLICATION: 1998-08 FORD RANGER EXTENDED CAB 4DR

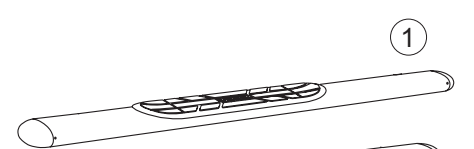
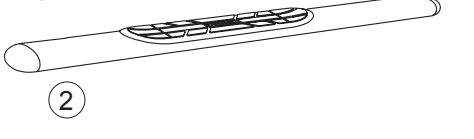
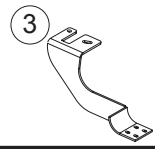
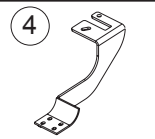
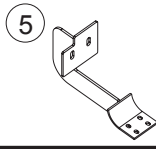
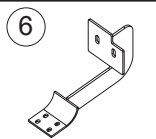
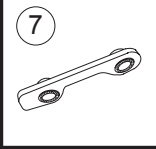
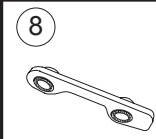
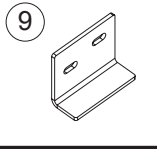
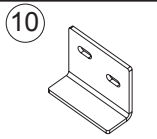
<p>MOUNT KIT 22-1455</p> <p>CHROME 22-0060, 22-5060</p> <p>BLACK 22-0065, 22-5065</p>	 								
---	--	--	--	---	---	---	---	---	---

ITEM	QTY	CONTENTS	TOOLS
1,2	2	STEP BAR, PASSENGER (1) AND DRIVER (2) PURCHASED SEPARATELY	9/16" SOCKET 9/16" WRENCH 7/16" SOCKET 7/16" WRENCH 13MM SOCKET RATCHET TORQUE WRENCH
3,4	2	FRONT BRACKET, PASSENGER (3) AND DRIVER (4)	
5,6	2	REAR BRACKET, PASSENGER (5) AND DRIVER (6)	
7,8	2	MOUNT PLATE ASSEMBLY, PASSENGER (7) AND DRIVER (8)	
9,10	2	MOUNT PLATE REAR, PASSENGER (9) AND DRIVER (10)	
11	8	3/8-16 X 1.50" HEX HEAD BOLT	
12	12	3/8" FLAT WASHER	
13	8	3/8" LOCK WASHER	
14	4	3/8-16 HEX NUT	
15	8	1/4-20 X .75 T-HEAD BOLT	
16	8	1/4" FLAT WASHER	
17	8	1/4-20 NYLON INSERT LOCK NUT	

- STEP 1.** Remove contents from box and check for damage. Verify all parts are present. Read instructions completely before beginning.
- STEP 2.** Locate front passenger mount holes (one slot and one hole) on cross member located in front of front body mount. Insert mount plate assembly into slot so that holes of the mount plate align with the holes on the vehicle.  
**NOTE:** High side of mount plate assembly should face up. **SEE FIGURES 1 AND 2.**
- STEP 3.** Attach front passenger bracket to vehicle using 3/8" fasteners as shown. Leave loose. **SEE FIGURE 2.**
- STEP 4.** Locate rear passenger mount holes on backside of rocker. Position rear passenger mount plate against inside surface of rocker panel through opening on the bottom of the rocker panel and align mounting holes. Place two 3/8-16 x 1.50" hex head bolts with 3/8" flat washers through the mount holes. Position the rear passenger mount bracket over the 3/8" fasteners and secure with two 3/8" flat washers, 3/8" lock washers, and 3/8-16 hex nuts. The rocker panel will be sandwiched between the rear mount plate and the rear mount bracket. **SEE FIGURE 3.**
- STEP 5.** Slide T-head bolts on step bar as shown (2 per slot, 4 per bar). Place step bar on saddle with the step pad closer to the front of the vehicle and end cap screws facing inward. Assemble with 1/4" fasteners. **SEE FIGURES 4 AND 5.**
- STEP 6.** Make sure step bar and brackets are properly aligned and tighten fasteners. Recommended torque values are 26 FT.LBS for 3/8" fasteners and 7 FT.LBS. for 1/4" fasteners.
- STEP 7.** Repeat for drivers side.

### FINISH PROTECTION

Westin products have a high quality finish that must be cared for like any other exposed finish on the vehicle. Protect the finish with a non-abrasive automotive wax, (e.g. Pure Carnauba) on a regular basis. The use of any soap, polish or wax that contains an abrasive is detrimental, as the compounds scratch the finish and open it to corrosion.

