



# INSTALLATION INSTRUCTIONS

APPLICATION: 2004-11 CHEVY COLORADO/GMC CANYON CREW CAB  
2006-08 ISUZU i-370 CREW CAB

AUTOMOTIVE PRODUCTS, INC.

MOUNT KIT <b>22-1395</b>  CHROME <b>22-0020, 22-5020</b>  BLACK <b>22-0025, 22-5025</b>							
ITEM	QTY	CONTENTS	TOOLS				
1,2	2	STEP BAR, PASSENGER (1) AND DRIVER (2) (PURCHASED SEPARATELY)	9/16" SOCKET				
3	4	FRONT/CENTER BRACKET	9/16" WRENCH				
4,5	2	REAR BRACKET, PASSENGER (4) AND DRIVER (5)	10MM SOCKET				
6	8	3/8-16 X 1.00" HEX HEAD BOLT	10MM WRENCH				
7	12	3/8" SAE FLAT WASHER	19MM SOCKET				
8	4	3/8" LOCK WASHER	MALLET				
9	4	3/8-16 HEX NUT	RATCHET				
10	4	EXTRUDED U-NUT	RATCHET EXTENSION				
11	6	M6 BOLT PLATES (INCLUDED WITH STEP TUBES )	TORQUE WRENCH				
12	24	M6 FLAT WASHERS (INCLUDED WITH STEP TUBES )	3/8" DRIVE UNIVERSAL JOINT				
13	24	M6 LOCK NUTS (INCLUDED WITH STEP TUBES)					

- STEP 1. Remove contents from box and check for damage. Verify all parts are present. Read instructions completely before beginning.
- STEP 2. Insert extruded u-nuts in 2 of the mount brackets as shown. These are for the front mount locations. **SEE FIGURE 1.**
- STEP 3. Install front brackets as shown. Use knuckle extension(s) with socket wrench for easier installation of front brackets. **NOTE:** Bolts are inserted up through bracket in body as shown. **SEE FIGURES 2 AND 3.**
- STEP 4. Install center brackets as shown. Hand tighten. **SEE FIGURE 4.**
- STEP 5. Attach rear mount brackets by removing body mount bolt and inserting through bracket as shown. Hand tighten. **SEE FIGURE 5.**  
**NOTE:** Body mount bolt will need to be tapped out of bushing with a mallet.
- STEP 6. Attach step bars to the mounting brackets using the M6 hardware included with the step bars. **SEE FIGURE 6,7,8**
- STEP 7. Make sure step bar and brackets are properly aligned and tighten fasteners. Recommended torque values are 74 Ft. Lbs. for body mount bolts, 26 Ft. Lbs. for 3/8" fasteners and 7 Ft. Lbs. for 1/4" fasteners.

#### FINISH PROTECTION

Westin products have a high quality finish that must be cared for like any other exposed finish on the vehicle. Protect the finish with a non-abrasive automotive wax, (e.g. Pure Carnauba) on a regular basis. The use of any soap, polish or wax that contains an abrasive is detrimental, as the compounds scratch the finish and open it

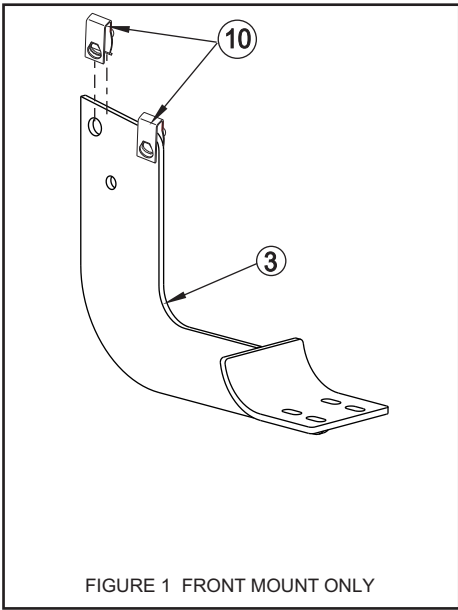

FIGURE 1 FRONT MOUNT ONLY

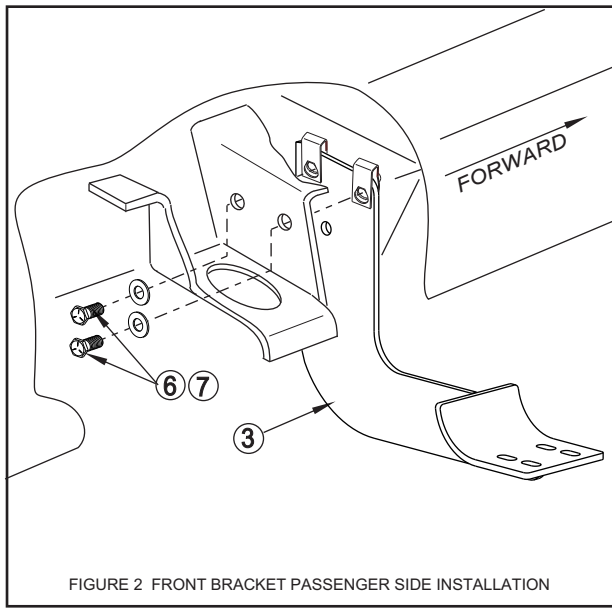

FIGURE 2 FRONT BRACKET PASSENGER SIDE INSTALLATION

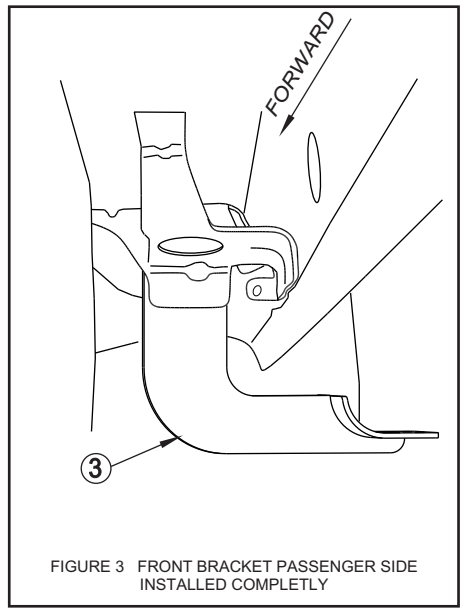

FIGURE 3 FRONT BRACKET PASSENGER SIDE INSTALLED COMPLETELY

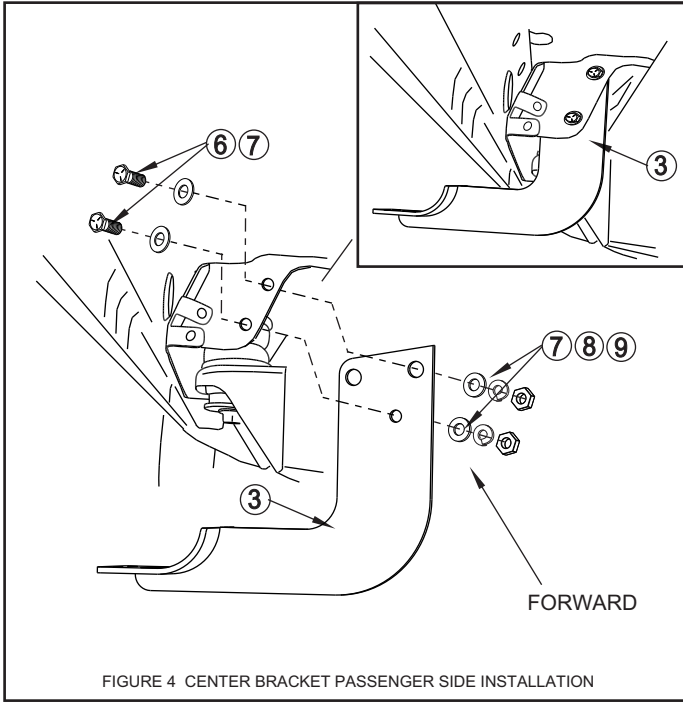

FIGURE 4 CENTER BRACKET PASSENGER SIDE INSTALLATION

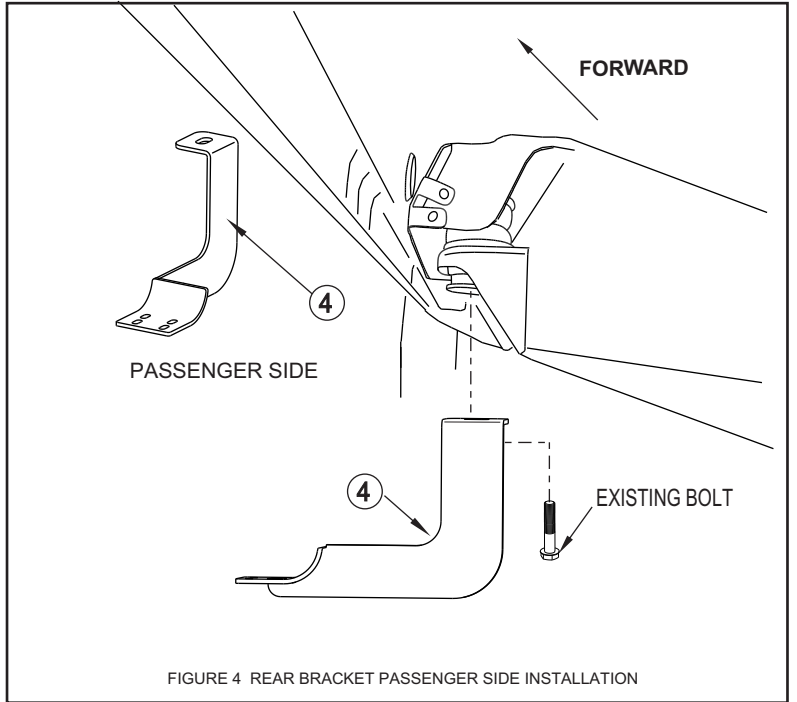

FIGURE 4 REAR BRACKET PASSENGER SIDE INSTALLATION

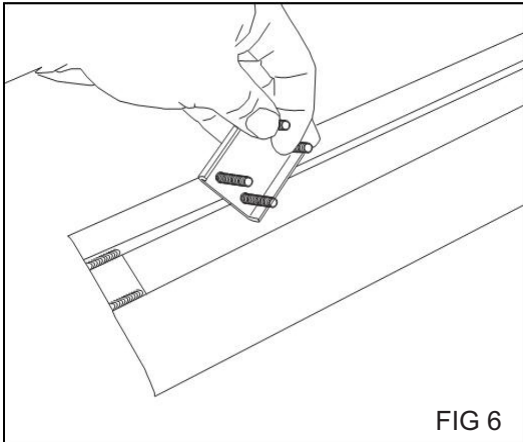

FIG 6

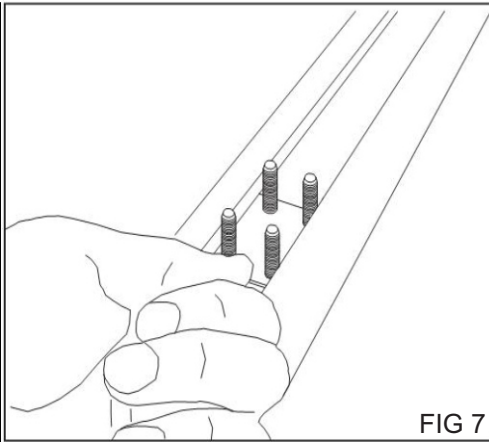

FIG 7

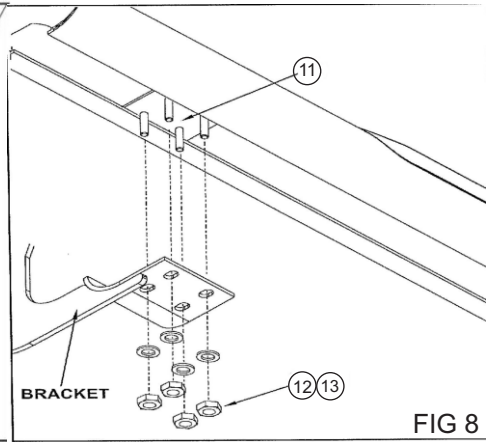

FIG 8